

# THREE TRAY SERVICE CART

**Model 06650**

## ASSEMBLY INSTRUCTIONS



3491 Mission Oaks Blvd., Camarillo, CA 93011  
Visit our Web site at <http://www.harborfreight.com>

Copyright © 2003 by Harbor Freight Tools®. All rights reserved. No portion of this manual or any artwork contained herein may be reproduced in any shape or form without the express written consent of Harbor Freight Tools.

**For technical questions please call 1-800-444-3353**

## SPECIFICATIONS

Item	Description
Construction	Steel Frame & Trays (3) w/Tubular Steel Handle
Finish	Red Enamel
Overall Dimensions	16" W X 32-1/2" H X30" L
Floor to Top Tray	29-1/4" H
Tray Depth	3-1/2"
Weight Capacity	400 Lbs.

## SAVE THIS MANUAL

You will need the manual for the safety warnings and precautions, assembly instructions, operating and maintenance procedures, parts list and diagram. Keep your invoice with this manual. Write the invoice number on the inside of the front cover. Keep the manual and invoice in a safe and dry place for future reference.

## SAFETY WARNINGS AND PRECAUTIONS

1. **KEEP PRODUCT USAGE AREA CLEAN.** Cluttered areas invite injuries. When assembling we recommend placing the product on flat, level surface such as carpet or grass to protect the finish.
2. **KEEP CHILDREN AWAY FROM PRODUCT DURING ASSEMBLY.** Two adults are better at assembling this product. Do not allow children to handle this product.
3. **DO NOT ATTEMPT TO ASSEMBLE OR USE THIS PRODUCT IF UNDER THE INFLUENCE OF ALCOHOL OR DRUGS.** Read warning labels on prescriptions to determine if your judgement or reflexes are impaired while taking drugs. If there is any doubt, do not attempt to assemble or use this product.
4. **USE EYE PROTECTION.** Wear ANSI approved safety impact goggles when assembling this product. Goggles are available from Harbor Freight Tools. Check
5. **CHECK FOR DAMAGED PARTS.** Before using this product, carefully check that it will operate properly and perform its intended function. Check for damaged parts and any other conditions that may affect its operation. Replace or repair damaged or worn parts immediately. Check Bolts and Nuts to be sure hardware has not loosened.
6. **AVOID OVERLOADING.** Trays should not be overloaded. Cart could tip over. There are no brakes on the wheels so use extreme caution if on a steep incline. Avoid slick or uneven surfaces. The weight capacity for the Service Cart is 400 lbs. Weight should be evenly distributed among the shelves with heavy weights on the bottom trays for better balance. Limit weight to 110 lbs. per tray.

7. **REPLACEMENT PARTS AND ACCESSORIES.** When servicing, use only identical replacement parts. Only use accessories intended for use with this product. Approved accessories are available from Harbor Freight Tools.
8. **THIS PRODUCT IS MANUFACTURED OF STEEL.** Do not force any part of the assembly and do not overtighten the bolts. Serious damage can occur. Do not stand on Service Cart. Use only for intended purpose. The Service Cart is made for adults. Children need to be supervised. Injury could occur if Service Cart is overloaded. Use caution!

## UNPACKING

When unpacking, check to make sure all parts shown on the Parts List (page 5) are included. If any parts are missing or broken, please call Harbor Freight Tools at the number shown on the cover of this manual as soon as possible.

## SERVICE CART

The Service Cart can tackle a wide variety of jobs from the warehouse, the garage, the library or anywhere a sturdy cart is needed. Remember, the Service Cart does not have brakes. Do not leave unattended on a sloping surface. Do not overload Cart, it could tip over.

## ASSEMBLY INSTRUCTIONS

### ASSEMBLY OF SERVICE CART

1. Assemble the Service Cart by using the included hardware, pliers and socket set (tools not included). After matching up the holes, begin by attaching the Lower Tray (B) to the Posts (G) at all four corners. The hardware for the four Posts (G) and Lower Tray (B) come in sets—1 Short Bolt, 1 Round Washer, 1 Lock Washer and 1 Nut (I) per set. Short Bolts (I) and Round Washers go on the outside of the Tray (B). The Lock Washers (I) and the Nuts go on the inside of the Tray. **See Figure 1.**

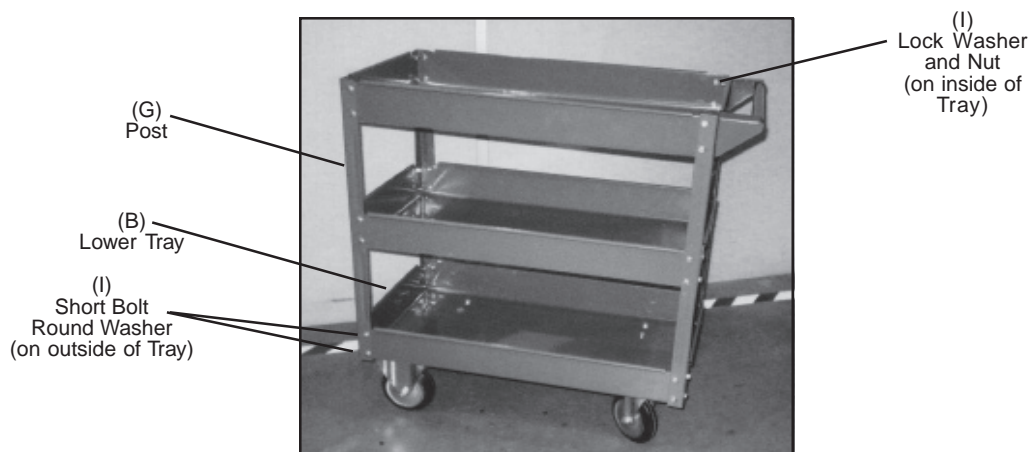

**Figure 1**

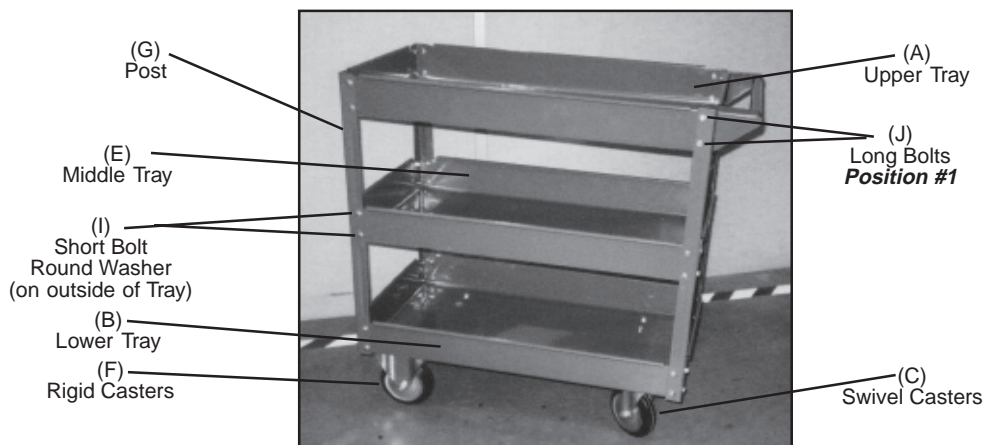

**Figure 2**

2. After matching up the holes, begin attaching the Middle Tray (E) to the Posts (G) on all four corners using the Short Bolts (I) and Round Washers on the outside of the Tray (E). The Lock Washers (I) and the Nuts go on the inside of the Tray. **See Figure 2.**
3. After matching up the holes, begin attaching the Upper Tray (A) to the Posts (G) on two corners as above with this exception: Do not insert Long Bolts (J) into position #1 until ready to attach Handle Brackets (H). **See Figure 3.**



**Figure 3**

4. Attach left Handle Bracket (H) on the left corner with Long Bolts (J), and Round Washers on the outside of the Service Cart. The Lock Washers and Nuts attach on the inside of the Upper Tray. **See Figure 3.**
5. Slip in Handle (D) into the left Handle Bracket (H). Insert the Handle (D) into the right Handle Bracket (H), then attach that bracket to the right corner of the Service Cart as above. Tighten all hardware.



**Figure 4**

6. Lie Service Tray down on a smooth surface. The Swivel Casters (C) attach underneath the Lower Tray (B) on the back of the tray through the holes. Use Wheel Bolt sets (K) to attach Casters (feed bolts down through top of Lower Tray). Use a 1/2" socket wrench for the Wheel Bolts (K). **See Figures 2 & 4.**
7. Repeat step #6 using the Rigid Casters (F) on the front of the Service Cart. Tighten all hardware. **See Figures 2 & 4.**
8. Set the Service Cart upright.

## MAINTENANCE

1. For better and safer performance, keep all parts of this product clean and dry at all times.

## PARTS LIST

PART#	DESCRIPTION	QTY
A	Upper Tray	1
B	Lower Tray	1
C	Swivel Caster	2
D	Handle	1
E	Middle Tray	1
F	Rigid Caster	2
G	Post	4
H	Handle Bracket (Right & Left)	1 ea.
I	Short Bolt Set M6 X 12	44
J	Long Bolt Set M6 X 14	4
K	Wheel Bolt Set M10 X 15	16

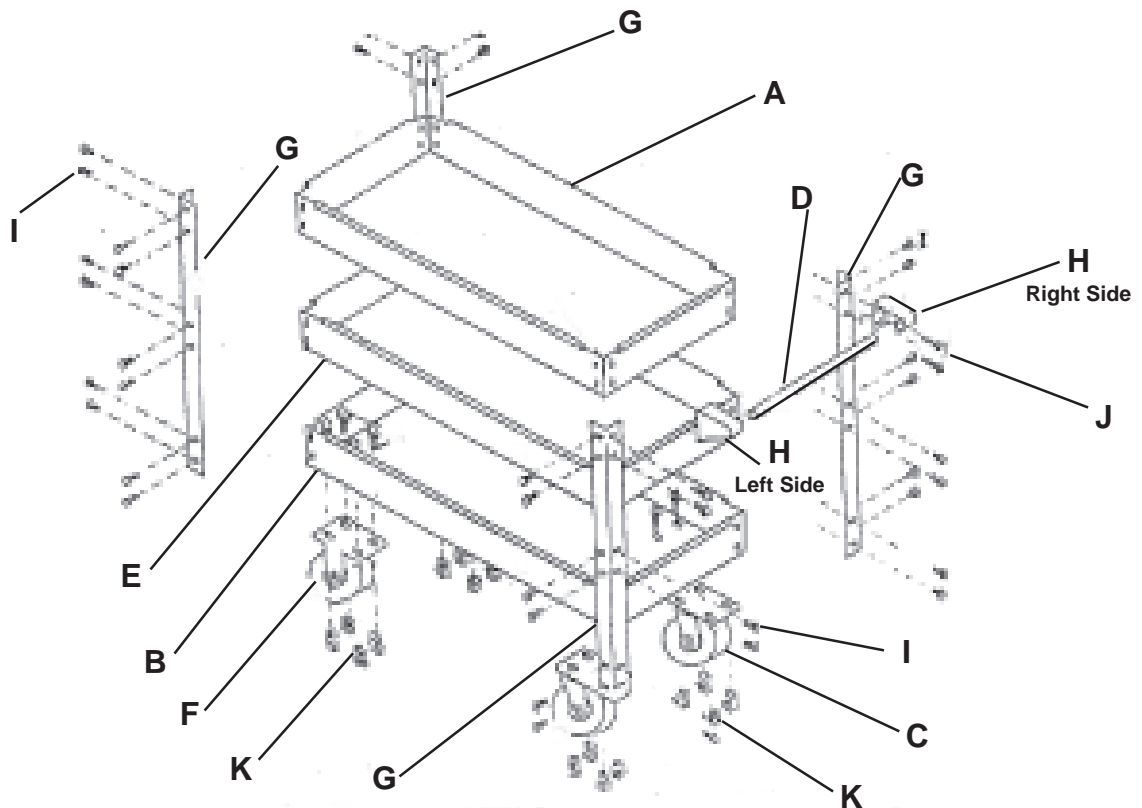

THE MANUFACTURER AND/OR DISTRIBUTOR HAS PROVIDED THE PARTS DIAGRAM IN THIS MANUAL AS A REFERENCE TOOL ONLY. NEITHER THE MANUFACTURER NOR DISTRIBUTOR MAKES ANY REPRESENTATION OR WARRANTY OF ANY KIND TO THE BUYER THAT HE OR SHE IS QUALIFIED TO MAKE ANY REPAIRS TO THE PRODUCT OR THAT HE OR SHE IS QUALIFIED TO REPLACE ANY PARTS OF THE PRODUCT. IN FACT, THE MANUFACTURER AND/OR DISTRIBUTOR EXPRESSLY STATES THAT ALL REPAIRS AND PARTS REPLACEMENTS SHOULD BE UNDERTAKEN BY CERTIFIED AND LICENSED TECHNICIANS AND NOT BY THE BUYER. THE BUYER ASSUMES ALL RISK AND LIABILITY ARISING OUT OF HIS OR HER REPAIRS TO THE ORIGINAL PRODUCT OR REPLACEMENT PARTS THERETO, OR ARISING OUT OF HIS OR HER INSTALLATION OF REPLACEMENT PARTS THERETO.