



# THROATLESS SHEAR

**Model 38413**

## ASSEMBLY AND OPERATING INSTRUCTIONS



Visit our website at: <http://www.harborfreight.com>



---

**Read this material before using this product.  
Failure to do so can result in serious injury.  
SAVE THIS MANUAL.**

---

Copyright© 1998 by Harbor Freight Tools®. All rights reserved. No portion of this manual or any artwork contained herein may be reproduced in any shape or form without the express written consent of Harbor Freight Tools. Diagrams within this manual may not be drawn proportionally. Due to continuing improvements, actual product may differ slightly from the product described herein. Tools required for assembly and service may not be included.

For technical questions or replacement parts, please call 1-800-444-3353.

Thank you for choosing a Harbor Freight Tools product! For future reference, please complete the owner's record below:

**Model:** \_\_\_\_\_

**Purchase Date:** \_\_\_\_\_

Save the receipt and these instructions. It is important that you read the entire instruction sheet to become familiar with this product before you begin using it.

## Specifications

Will cut mild steel, aluminum, stainless steel or lighter material.

-18" handle

-Blades: Alloy tool steel, 4" length

-Base Size: 5-1/8" x 3-7/8" with three mounting holes (3/8" diameter)

## WARNING!

Common sense and caution are factors which cannot be built into any product. These factors must be supplied by the operator. Please remember:

1. Stay alert. Never operate equipment or use tools if you are tired.
2. Do not use this product if under the influence of alcohol or drugs. Read warning labels on prescriptions to determine if your judgement or reflexes might be impaired.
3. Do not wear loose clothing or jewelry as they can be caught in moving parts.
4. Nonskid footwear is recommended.
5. Wear restrictive hair covering to contain long hair.
6. Use eye protection. Always wear ANSI-approved safety glasses when using equipment or tools.
7. Keep proper footing and balance at all times.

## Work Area Precautions

To avoid risk of personal injury, equipment damage, fire and shock, make sure your work area is:

1. Free of damp, wet or rainy conditions.
2. Free of children. Children should never handle tools or operate equipment.
3. Make sure your work area is well lighted.
4. Clean and uncluttered work spaces contribute to safe and productive work conditions.

## Before Operating

Check for alignment and binding of all moving parts, broken parts or mounting fixtures and any other condition that may affect proper operation. Any part that is damaged should be properly repaired or replaced by a qualified technician.

## Operation Precautions

1. Never force the tool or attachment to do the work of a larger industrial tool. It is designed to do the job better and more safely at the rate for which it was intended.
2. Never use the blades if they are dull, worn, or chipped. Blades must be sharpened, repaired or replaced before using.
3. Check to make sure all bolts are secure but not overtightened. Check for blade clearance. Make sure clearance is suitable for the workpiece.
4. While being used, the lower blade must be secured with the Clamp. When not being used, the Clamp (10) can be loosened.

## Assembly Instructions

Assemble the Handle (6) over the exposed shaft of the Geared Handle (4) and tighten Bolt (5).

## Operation Instructions

1. Adjust the clearance between the Upper Blade (14) and Lower Blade (8). To decrease the clearance, turn the Adjusting Bolts (15) clockwise. To increase clearance, turn the bolts counterclockwise. The clearance can be adjusted to between 1/4 and 1/10 of the thickness of the workpiece.
2. To gain power and control of the workpiece, start all cuts at the heel of the blades. Circular and irregular cuts are made by turning the workpiece while following through with the downward stroke of the blade.
3. When a cut has been finished, push the workpiece forward while raising the handle to lift the blade above the workpiece. Start the next cut at the heel of the blade.
4. Always keep the material being cut flat on the bed of the shear.

## Maintenance Instructions

Periodically use a good graphite oil to lubricate blade edges and gears on the Geared Handle (4).

## Parts List and Assembly Diagram

Part	Description	Qty
1	Base	1
2	Right Stand	1
3	Blade Stand	1
4	Geared Handle	1
5	Bolt M8x16	1
6	Handle	1

Part	Description	Qty
7	Handle Bushing	1
8	Lower Blade	1
9	Bolt M8x30	1
10	Clamp	1
11	Nut M12	1
12	Bolt M12	2

Part	Description	Qty
13	Bolt M5x8	3
14	Upper Blade	1
15	Adjusting Bolts M5x35	1
16	Adjusting Bolt M5x20	1
17	Spring Washer	1
18	Screw Driver	1

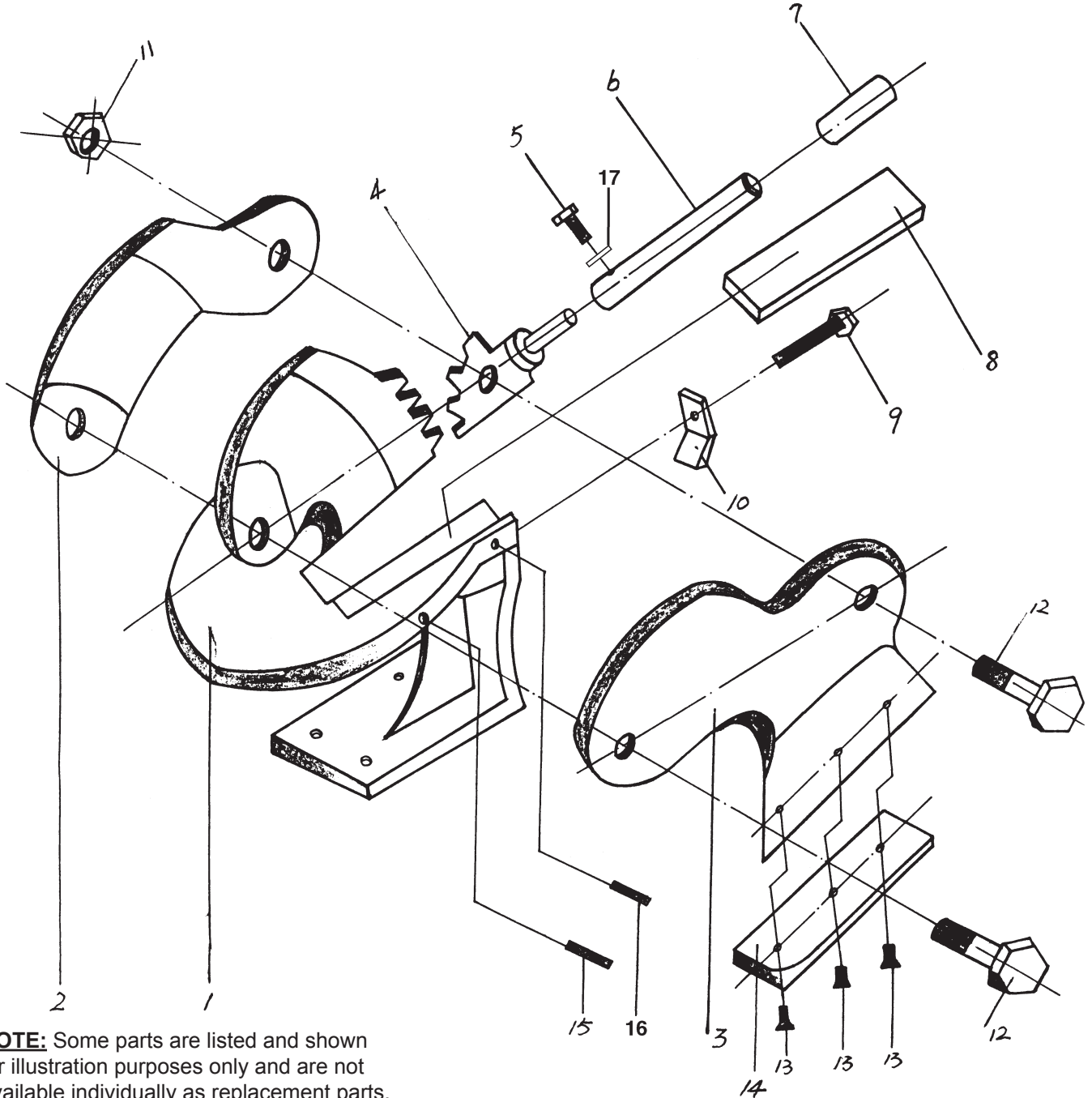

**NOTE:** Some parts are listed and shown for illustration purposes only and are not available individually as replacement parts.

### PLEASE READ THE FOLLOWING CAREFULLY

THE MANUFACTURER AND/OR DISTRIBUTOR HAS PROVIDED THE PARTS DIAGRAM IN THIS MANUAL AS A REFERENCE TOOL ONLY. NEITHER THE MANUFACTURER NOR DISTRIBUTOR MAKES ANY REPRESENTATION OR WARRANTY OF ANY KIND TO THE BUYER THAT HE OR SHE IS QUALIFIED TO MAKE ANY REPAIRS TO THE PRODUCT OR THAT HE OR SHE IS QUALIFIED TO REPLACE ANY PARTS OF THE PRODUCT. IN FACT, THE MANUFACTURER AND/OR DISTRIBUTOR EXPRESSLY STATES THAT ALL REPAIRS AND PARTS REPLACEMENTS SHOULD BE UNDERTAKEN BY CERTIFIED AND LICENSED TECHNICIANS AND NOT BY THE BUYER. THE BUYER ASSUMES ALL RISK AND LIABILITY ARISING OUT OF HIS OR HER REPAIRS TO THE ORIGINAL PRODUCT OR REPLACEMENT PARTS THERETO, OR ARISING OUT OF HIS OR HER INSTALLATION OF REPLACEMENT PARTS THERETO.

## Limited 90 Day Warranty

Harbor Freight Tools Co. makes every effort to assure that its products meet high quality and durability standards, and warrants to the original purchaser that this product is free from defects in materials and workmanship for the period of 90 days from the date of purchase. This warranty does not apply to damage due directly or indirectly, to misuse, abuse, negligence or accidents, repairs or alterations outside our facilities, criminal activity, improper installation, normal wear and tear, or to lack of maintenance. We shall in no event be liable for death, injuries to persons or property, or for incidental, contingent, special or consequential damages arising from the use of our product. Some states do not allow the exclusion or limitation of incidental or consequential damages, so the above limitation of exclusion may not apply to you. THIS WARRANTY IS EXPRESSLY IN LIEU OF ALL OTHER WARRANTIES, EXPRESS OR IMPLIED, INCLUDING THE WARRANTIES OF MERCHANTABILITY AND FITNESS.

To take advantage of this warranty, the product or part must be returned to us with transportation charges prepaid. Proof of purchase date and an explanation of the complaint must accompany the merchandise. If our inspection verifies the defect, we will either repair or replace the product at our election or we may elect to refund the purchase price if we cannot readily and quickly provide you with a replacement. We will return repaired products at our expense, but if we determine there is no defect, or that the defect resulted from causes not within the scope of our warranty, then you must bear the cost of returning the product.

This warranty gives you specific legal rights and you may also have other rights which vary from state to state.



3491 Mission Oaks Blvd. • PO Box 6009 • Camarillo, CA 93011 • (800) 444-3353