

Owner's Manual & Safety Instructions

Save This Manual Keep this manual for the safety warnings and precautions, assembly, operating, inspection, maintenance and cleaning procedures. Write the product's serial number in the back of the manual near the assembly diagram (or month and year of purchase if product has no number). Keep this manual and the receipt in a safe and dry place for future reference.

22i



18" BENDING BRAKE



Visit our website at: <http://www.harborfreight.com>
Email our technical support at: productsupport@harborfreight.com

39103

When unpacking, make sure that the product is intact and undamaged. If any parts are missing or broken, please call 1-888-866-5797 as soon as possible.

Copyright© 2022 by Harbor Freight Tools®. All rights reserved.
No portion of this manual or any artwork contained herein may be reproduced in any shape or form without the express written consent of Harbor Freight Tools. Diagrams within this manual may not be drawn proportionally. Due to continuing improvements, actual product may differ slightly from the product described herein.
Tools required for assembly and service may not be included.

⚠️ WARNING

Read this material before using this product.
Failure to do so can result in serious injury.
SAVE THIS MANUAL.

Specifications

Bending Capacity	90° Bends in 18" Wide Stock x 18 Gauge Aluminum / 20 Gauge Steel
Mounting Hardware	Requires Four 1/4" Diameter Bolts, Nuts and Flat Washers (not supplied)

IMPORTANT SAFETY INFORMATION

Assembly Precautions

1. Assemble only according to these instructions. Improper assembly can create hazards.
2. Wear ANSI-approved safety goggles and heavy-duty work gloves during assembly.
3. Keep assembly area clean and well lit.
4. Keep bystanders out of the area during assembly.
5. Do not assemble when tired or when under the influence of alcohol, drugs or medication.
6. Weight capacity and other product capabilities apply to properly and completely assembled product only.
7. Assemble only according to these instructions. Improper assembly can create hazards.
8. Mount only to flat, stable bench top able to support weight of Bending Brake, item being bent, and the bending force.
9. Verify that installation surface has no hidden utility lines before drilling the bolts.

Use Precautions

1. This product is not a toy. Do not allow children to play with or near this item.
2. Use as intended only.
3. Inspect before every use; do not use if parts are loose or damaged.
4. Do not exceed listed weight capacity.
Be aware of dynamic loading!
Sudden load movement may briefly create excess load causing product failure.
5. Maintain product labels and nameplates. These carry important safety information. If unreadable or missing, contact Harbor Freight Tools for a replacement.
6. Do not exceed maximum bend capacity of 18" wide stock of 18 gauge aluminum or 20 gauge steel.
7. Wear ANSI-approved safety goggles and heavy-duty work gloves during use.
8. Keep fingers clear of Support Plate (1C) and Folding Plate (1B) during use.
9. Keep bystanders out of the area during use.
10. Keep work area clean and well lit.
11. Do not use when tired or when under the influence of drugs, alcohol or medication.

Assembly and Operating Instructions



Read the **ENTIRE IMPORTANT SAFETY INFORMATION** section at the beginning of this document including all text under subheadings therein before set up or use of this product.

1. Secure the Mounting Stands (1A) to the work bench using four 1/4" mounting bolts (not included).
2. Attach Handle Balls (4) to the Handle Levers (3) and then thread Handle Levers into the ends of the Folding Plate (1B). See Assembly Diagram.
3. For easier operation, use a scribe (not included) to scribe a straight line across the metal sheet to be bent.
4. Use the Handle Levers to lower the Folding Plate. Position the material to be bent across the Support Plate (1C) and the Folding Plate.
5. Place the wider base of the Pressing Plate (2) over the material. Align its edge with the marked bend line, allowing for an approximate extra gap of 0-1/8" for sheet bend stretch.
Please note: Test on a scrap sheet to establish the correct required gap.
6. Use clamps (not included) or other appropriate clamping tools to clamp down the Pressing Plate.
7. Raise the Handle Levers to bend material to desired angle.
8. **WARNING! TO PREVENT SERIOUS INJURY:** Keep fingers clear of Support Plate and Moving Plates during use.
9. **Please note:** Handle Levers are not designed to be permanently mounted to the Mounting Stands.
10. After work is complete, remove Pressing Plate and wipe all surfaces clean. Then wipe down rest of Bending Brake with a soft, clean cloth and store Bending Brake in a secure and dry area away from children.

Parts List and Diagram

Part	Description	Qty
1A	Mounting Stands (Base Assembly)	2
1B	Folding Plate (Base Assembly)	1
1C	Support Plate (Base Assembly)	1
2	Pressing Plate	1
3	Handle Lever	2
4	Handle Ball	2

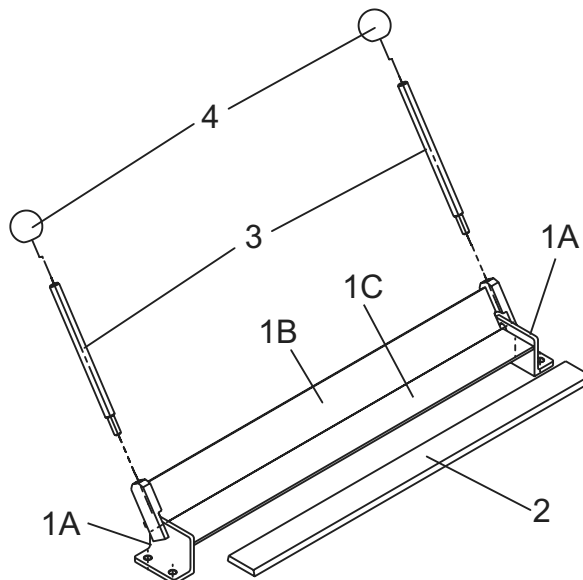

Figure A: Assembly Diagram

Record Product's Serial Number Here: _____

Note: If product has no serial number, record month and year of purchase instead.

Note: Some parts are listed and shown for illustration purposes only, and are not available individually as replacement parts.

Visit harborfreight.com/parts for a list of in stock parts. Reference UPC 193175500540.

PLEASE READ THE FOLLOWING CAREFULLY

THE MANUFACTURER AND/OR DISTRIBUTOR HAS PROVIDED THE PARTS LIST AND ASSEMBLY DIAGRAM IN THIS DOCUMENT AS A REFERENCE TOOL ONLY. NEITHER THE MANUFACTURER OR DISTRIBUTOR MAKES ANY REPRESENTATION OR WARRANTY OF ANY KIND TO THE BUYER THAT HE OR SHE IS QUALIFIED TO MAKE ANY REPAIRS TO THE PRODUCT, OR THAT HE OR SHE IS QUALIFIED TO REPLACE ANY PARTS OF THE PRODUCT. IN FACT, THE MANUFACTURER AND/OR DISTRIBUTOR EXPRESSLY STATES THAT ALL REPAIRS AND PARTS REPLACEMENTS SHOULD BE UNDERTAKEN BY CERTIFIED AND LICENSED TECHNICIANS, AND NOT BY THE BUYER. THE BUYER ASSUMES ALL RISK AND LIABILITY ARISING OUT OF HIS OR HER REPAIRS TO THE ORIGINAL PRODUCT OR REPLACEMENT PARTS THERETO, OR ARISING OUT OF HIS OR HER INSTALLATION OF REPLACEMENT PARTS THERETO.

Limited 90 Day Warranty

Harbor Freight Tools Co. makes every effort to assure that its products meet high quality and durability standards, and warrants to the original purchaser that this product is free from defects in materials and workmanship for the period of 90 days from the date of purchase. This warranty does not apply to damage due directly or indirectly, to misuse, abuse, negligence or accidents, repairs or alterations outside our facilities, criminal activity, improper installation, normal wear and tear, or to lack of maintenance. We shall in no event be liable for death, injuries to persons or property, or for incidental, contingent, special or consequential damages arising from the use of our product. Some states do not allow the exclusion or limitation of incidental or consequential damages, so the above limitation of exclusion may not apply to you. THIS WARRANTY IS EXPRESSLY IN LIEU OF ALL OTHER WARRANTIES, EXPRESS OR IMPLIED, INCLUDING THE WARRANTIES OF MERCHANTABILITY AND FITNESS.

To take advantage of this warranty, the product or part must be returned to us with transportation charges prepaid. Proof of purchase date and an explanation of the complaint must accompany the merchandise. If our inspection verifies the defect, we will either repair or replace the product at our election or we may elect to refund the purchase price if we cannot readily and quickly provide you with a replacement. We will return repaired products at our expense, but if we determine there is no defect, or that the defect resulted from causes not within the scope of our warranty, then you must bear the cost of returning the product.

This warranty gives you specific legal rights and you may also have other rights which vary from state to state.

