



18" Bending Brake

Model 39103

Assembly and Operating Instructions



3491 Mission Oaks Blvd., Camarillo, CA 93011

Copyright © 1998 by Harbor Freight Tools®. All rights reserved.
No portion of this manual or any artwork contained herein may
be reproduced in any shape or form without the express written
consent of Harbor Freight Tools.

For technical questions and replacement parts, please call 1-800-444-3353

Specifications

Bending Capacity: Bend material up to 16 gauge steel; make up to 90° bends; bends material up to 18 inches wide; Designed for bench top mounting using 1/4" diameter bolts.

Dimensions: 21"L x 3"W x 3-1/2"H

Weight: 9 Lbs.

Save This Manual

You will need the manual for the safety warnings and precautions, assembly instructions, operating and maintenance procedures, parts list and diagram. Keep your invoice with this manual. Write the invoice number on the inside of the front cover. Keep the manual and invoice in a safe and dry place for future reference.

Safety Warnings and Precautions

WARNING: When using tool, basic safety precautions should always be followed to reduce the risk of personal injury and damage to equipment.

Read all instructions before using this tool!

1. **Keep work area clean.** Cluttered areas invite injuries.
2. **Observe work area conditions.** Do not use machines or power tools in damp or wet locations. Don't expose to rain. Keep work area well lighted. Do not use electrically powered tools in the presence of flammable gases or liquids.
3. **Keep children away.** Children must never be allowed in the work area. Do not let them handle machines, tools, or extension cords.
4. **Store idle equipment.** When not in use, tools must be stored in a dry location to inhibit rust. Always lock up tools and keep out of reach of children.
5. **Do not force tool.** It will do the job better and more safely at the rate for which it was intended. Do not use inappropriate attachments in an attempt to exceed the tool capacity.
6. **Use the right tool for the job.** Do not attempt to force a small tool or attachment to do the work of a larger industrial tool. Do not use a tool for a purpose for which it was not intended.
7. **Dress properly.** Do not wear loose clothing or jewelry as they can be caught in moving parts. Protective, electrically nonconductive clothes and nonskid footwear are recommended when working. Wear restrictive hair covering to contain long hair.

8. **Use eye and ear protection.** Always wear ANSI-approved impact safety goggles. Wear a full face shield if you are producing metal filings or wood chips. Wear an ANSI-approved dust mask or respirator when working around metal, wood, and chemical dusts and mists.
9. **Do not overreach.** Keep proper footing and balance at all times. Do not reach over or across running machines.
10. **Maintain tools with care.** Keep tools sharp and clean for better and safer performance. Follow instructions for lubricating and changing accessories. The handles must be kept clean, dry, and free from oil and grease at all times.
11. **Stay alert.** Watch what you are doing, use common sense. Do not operate any tool when you are tired.
12. **Check for damaged parts.** Before using any tool, any part that appears damaged should be carefully checked to determine that it will operate properly and perform its intended function. Check for alignment and binding of moving parts; any broken parts or mounting fixtures; and any other condition that may affect proper operation. Any part that is damaged should be properly repaired or replaced by a qualified technician.
13. **Guard against electric shock.** Prevent body contact with grounded surfaces such as pipes, radiators, ranges, and refrigerator enclosures.
14. **Replacement parts and accessories.** When servicing, use only identical replacement parts. Use of any other parts will void the warranty. Only use accessories intended for use with this tool. Approved accessories are available from Harbor Freight Tools.
15. **Do not operate tool if under the influence of alcohol or drugs.** Read warning labels on prescriptions to determine if your judgment or reflexes are impaired while taking drugs. If there is any doubt, do not operate the tool.

Note: The warnings and instructions contained in this instruction manual cannot cover all possible conditions and situations that may occur when using this product. It must be understood that common sense and caution are factors which cannot be built into this product. These factors must be supplied by the person operating this piece of equipment.

Assembly and Operating Instructions

The 18" Bending Brake requires some minor assembly as described below. Please refer to the parts diagram on page 5 and the part number listing shown below when reading these instructions.

1. The Base Assembly (#1) should be secured to a work bench using the mounting holes and 4 bolts (1/4" diameter).
2. Each Handle Ball (#7) should be attached to the Handle Lever (#6) and the Handle Levers should be placed into the Pins of Base Assembly (#1).
3. To use the Bending Brake, lower the Handle Lever (#6) until the Moving Plate of Base Assembly (#1) is parallel to the work bench. Position the material to be bent on the Supporting Plate of Base Assembly (#1) and the Moving Plate of Base Assembly (#1) and properly align with the edge to be bent up against the back edge of the Supporting Plate of Base Assembly (#1).
4. Place and secure the Pressing Plate (#3) on top of the Supporting Plate of Base Assembly (#1) with the back edge of Pressing Plate of Base Assembly (#1) aligned with back edge of Supporting Plate of Base Assembly (#1).
5. Raise the two Handle Levers (#6) to bend the material to the desired angle.

Warning: When using the Bending Brake keep fingers clear of the Supporting Plate and Moving Plate to avoid personal injury.

6. When the Bending Brake is not in use, it should be covered and stored in a dry location.

Part Number Listing

Part #	Description	Qty
1	Base Assembly 1	
3	Pressing Plate	1
6	Handle Lever	2
7	Handle Ball	2

Parts Diagram

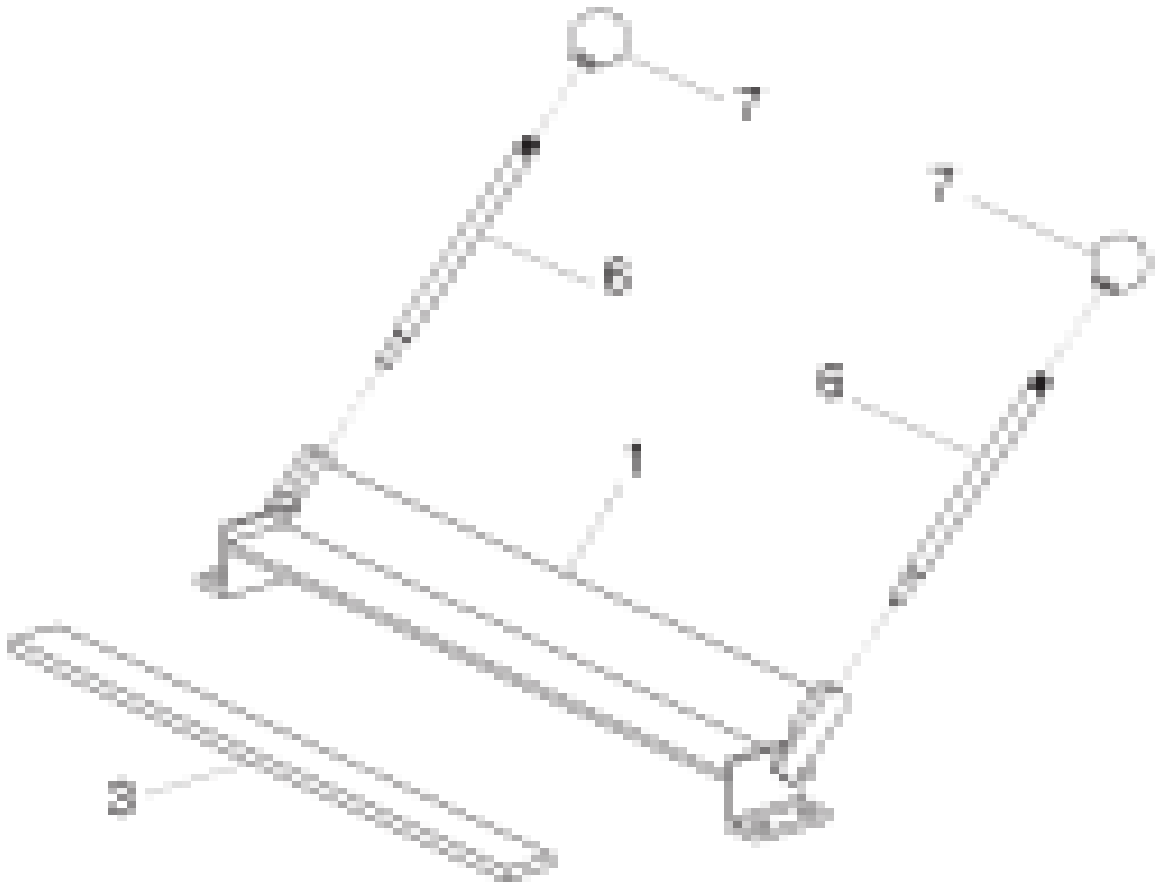

90 Day Warranty

Harbor Freight Tools Co. makes every effort to assure that its products meet high quality and durability standards, and warrants to the original purchaser that this product is free from defects in materials and workmanship for the period of 90 days from the date of purchase. This warranty does not apply to damage due directly or indirectly, to misuse, abuse, negligence or accidents, repairs or alterations outside our facilities, criminal activity, improper installation, normal wear and tear, or to lack of maintenance. We shall in no event be liable for death, injuries to persons or property, or for incidental, contingent, special or consequential damages arising from the use of our product. Some states do not allow the exclusion or limitation of incidental or consequential damages, so the above limitation of exclusion may not apply to you. This warranty is expressly in lieu of all other warranties, express or implied, including the warranties of merchantability and fitness.

To take advantage of this warranty, the product or part must be returned to us with transportation charges prepaid. Proof of purchase date and an explanation of the complaint must accompany the merchandise. If our inspection verifies the defect, we will either repair or replace the product at our election or we may elect to refund the purchase price if we cannot readily and quickly provide you with a replacement. We will return repaired products at our expense, but if we determine there is no defect, or that the defect resulted from causes not within the scope of our warranty, then you must bear the cost of returning the product.

This warranty gives you specific legal rights and you may also have other rights which vary from state to state.