

Portable Wheel Balancer

Item 39741

▲WARNING

**Read this material before using this product.
Failure to do so can result in serious injury.
SAVE THIS MANUAL.**



When unpacking, make sure that the product is intact and undamaged.
If any parts are missing or broken, please call 1-800-444-3353 as soon as possible.

Visit our website at: <http://www.harborfreight.com>

Email our technical support at: tech@harborfreight.com

Specifications

Hub Capacities	1-1/2 IN. to 4 IN. Diameter
Type of Wheels	Light Truck and Automobile

Save This Manual

Keep this manual for the safety warnings and precautions, assembly, operating, inspection, maintenance and cleaning procedures. Write the product's serial number in the back of the manual near the assembly diagram (or month and year of purchase if product has no number). Keep this manual and the receipt in a safe and dry place for future reference.

Important Safety Information

In this manual, on the labeling, and all other information provided with this product:



This is the safety alert symbol. It is used to alert you to potential personal injury hazards. Obey all safety messages that follow this symbol to avoid possible injury or death.

DANGER

DANGER indicates a hazardous situation which, if not avoided, will result in death or serious injury.

WARNING

WARNING indicates a hazardous situation which, if not avoided, could result in death or serious injury.

CAUTION

CAUTION, used with the safety alert symbol, indicates a hazardous situation which, if not avoided, could result in minor or moderate injury.

NOTICE

NOTICE is used to address practices not related to personal injury.

CAUTION

CAUTION, without the safety alert symbol, is used to address practices not related to personal injury.

Safety Warnings



WARNING Read all safety warnings and instructions. *Failure to follow the warnings and instructions may result in serious injury.*

Save all warnings and instructions for future reference.

1. **Do not use the Wheel Balancer until properly trained.** This product is intended for use by properly trained and experienced personnel only. If you are not familiar with the proper and safe operation of a wheel balancer, do not use until trained.
2. **Keep work area clean and well lit.** Cluttered areas invite injuries.
3. **Keep children away.** Children must never be allowed in the work area. Do not let them handle machines, tools, or extension cords.
4. **Store idle equipment.** When not in use, tools must be stored in a dry location to inhibit rust.
5. **Do not force tool.** It will do the job better and more safely at the rate for which it was intended. Do not use inappropriate attachments in an attempt to exceed the tool capacity.
6. **Dress properly.** Do not wear loose clothing or jewelry as they can be caught in moving parts. Protective, electrically nonconductive clothes and nonskid footwear are recommended when working. Wear restrictive hair covering to contain long hair.
7. **Use eye protection.** Always wear ANSI-approved impact safety goggles.
8. **Stay alert.** Watch what you are doing; use common sense. Do not operate any tool when you are tired.

9. **Check for damaged parts.** Before using any tool, any part that appears damaged should be carefully checked to determine that it will operate properly and perform its intended function. Check for alignment and binding of moving parts; any broken parts or mounting fixtures; and any other condition that may affect proper operation. Any part that is damaged should be properly repaired or replaced by a qualified technician.

10. **Replacement parts and accessories.** When servicing, use only identical replacement parts. Use of any other parts will void the warranty. Only use accessories intended for use with this tool.

11. **Do not operate tool if under the influence of alcohol or drugs.** Read warning labels on prescriptions to determine if your judgment or reflexes are impaired while taking drugs. If there is any doubt, do not operate the tool.

 **SAVE THESE INSTRUCTIONS.**

Assembly



WARNING Read all safety warnings and instructions. Failure to follow the warnings and instructions may result in serious injury.

Save all warnings and instructions for future reference.

Part numbers used below refer to the Parts Diagram and Part Number Listing on page 5.

1. Thread Nut (10) onto threaded end of Shaft (9). Then slide Flat Washer (10) onto threaded end of Shaft.
2. Insert the threaded end of the Shaft (9) into the Base (12).

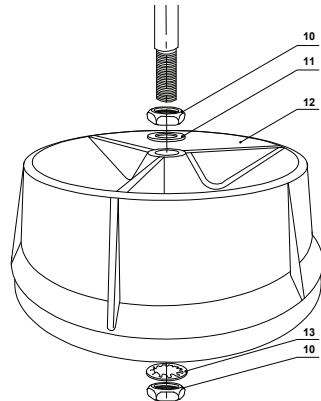

3. Use Lock Washer (13) and Nut (10) from underneath to secure the Shaft.
4. The Balancing Cone Set (7) rests on top of the tip located on top of the Shaft (9). The tip of the Shaft fits into the recessed area on the underside of the Balancing Cone Set. When properly fitted, the bubble in the Level (4) should be perfectly centered.

Note: Use the level to make sure this tool is positioned on a flat, level surface.

5. With the Wheel Balancer in place, check the balance of the Flange Set (1). Lightly tilt the Flange Set and let it come to rest. It should easily rock back and forth and come to rest with the bubble centered in the Level.

Operation



WARNING Read all safety warnings and instructions. *Failure to follow the warnings and instructions may result in serious injury.*

Save all warnings and instructions for future reference.

1. Remove all old wheel weights from the wheel to be balanced.
2. Lay the rim of the wheel to be balanced down **centered** over the top of the Flange Set. If the wheel is not properly balanced, the bubble inside the Level will not be centered and will rest to one side of the Level.
3. Put one or more wheel weights on the side of the rim where the bubble rests to center the bubble in the Level. When the bubble is centered, the wheel is balanced. Secure the wheel weights to the rim.
4. Once balanced, remove the wheel from the Flange Set (1).

Maintenance and Servicing



Procedures not specifically explained in this manual must be performed only by a qualified technician.

CAUTION

TO PREVENT INJURY FROM TOOL FAILURE: Do not use damaged equipment. If damaged or loose parts are noted, have the problem corrected before further use.

1. **BEFORE EACH USE**, inspect the general condition of the tool. Check for loose hardware, misalignment or binding of moving parts, cracked or broken parts, and any other condition that may affect its safe operation.
2. **AFTER USE**, wipe external surfaces of the tool with clean cloth.

PLEASE READ THE FOLLOWING CAREFULLY

THE MANUFACTURER AND/OR DISTRIBUTOR HAS PROVIDED THE PARTS LIST AND ASSEMBLY DIAGRAM IN THIS MANUAL AS A REFERENCE TOOL ONLY. NEITHER THE MANUFACTURER OR DISTRIBUTOR MAKES ANY REPRESENTATION OR WARRANTY OF ANY KIND TO THE BUYER THAT HE OR SHE IS QUALIFIED TO MAKE ANY REPAIRS TO THE PRODUCT, OR THAT HE OR SHE IS QUALIFIED TO REPLACE ANY PARTS OF THE PRODUCT. IN FACT, THE MANUFACTURER AND/OR DISTRIBUTOR EXPRESSLY STATES THAT ALL REPAIRS AND PARTS REPLACEMENTS SHOULD BE UNDERTAKEN BY CERTIFIED AND LICENSED TECHNICIANS, AND NOT BY THE BUYER. THE BUYER ASSUMES ALL RISK AND LIABILITY ARISING OUT OF HIS OR HER REPAIRS TO THE ORIGINAL PRODUCT OR REPLACEMENT PARTS THERETO, OR ARISING OUT OF HIS OR HER INSTALLATION OF REPLACEMENT PARTS THERETO.

Parts List and Assembly Diagram

Part	Description	Qty.
1	Flange Set	1
2	Rod and Spring Set	4
3	Screw (M2.5 x 20)	3
4	Level	1
5	Washer	1
6	Level Spring	1
7	Balancing Cone Set	1
8	Retaining Pin	4
9	Shaft	1
10	Nut (M20 x 1.5)	2
11	Flat Washer	1
12	Base	1
13	Lock Washer	1
14	Shaft Receiver	1

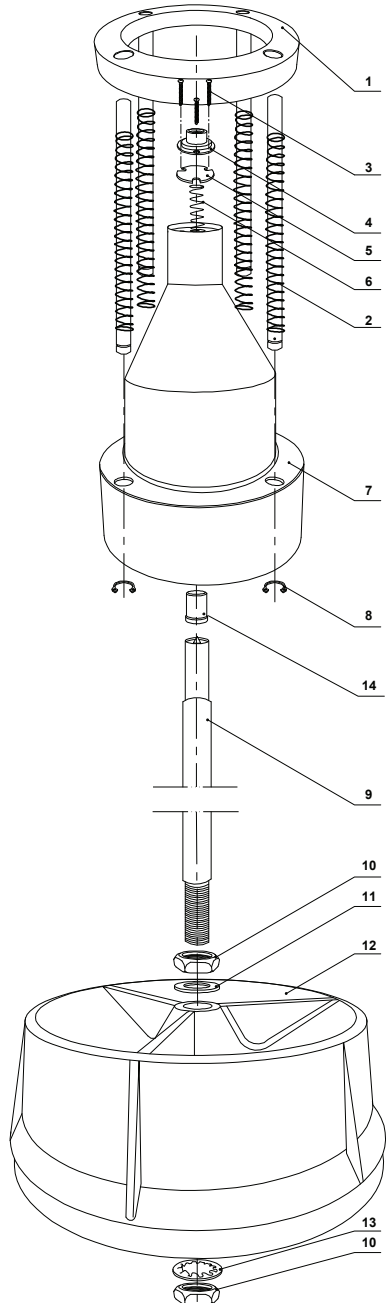

Record Product's Serial Number Here:

Note: If product has no serial number, record month and year of purchase instead.

Note: Some parts are listed and shown for illustration purposes only, and are not available individually as replacement parts.

90 Day Warranty

Harbor Freight Tools Co. makes every effort to assure that its products meet high quality and durability standards, and warrants to the original purchaser that this product is free from defects in materials and workmanship for the period of 90 days from the date of purchase. This warranty does not apply to damage due directly or indirectly, to misuse, abuse, negligence or accidents, repairs or alterations outside our facilities, criminal activity, improper installation, normal wear and tear, or to lack of maintenance. We shall in no event be liable for death, injuries to persons or property, or for incidental, contingent, special or consequential damages arising from the use of our product. Some states do not allow the exclusion or limitation of incidental or consequential damages, so the above limitation of exclusion may not apply to you. THIS WARRANTY IS EXPRESSLY IN LIEU OF ALL OTHER WARRANTIES, EXPRESS OR IMPLIED, INCLUDING THE WARRANTIES OF MERCHANTABILITY AND FITNESS.

To take advantage of this warranty, the product or part must be returned to us with transportation charges prepaid. Proof of purchase date and an explanation of the complaint must accompany the merchandise. If our inspection verifies the defect, we will either repair or replace the product at our election or we may elect to refund the purchase price if we cannot readily and quickly provide you with a replacement. We will return repaired products at our expense, but if we determine there is no defect, or that the defect resulted from causes not within the scope of our warranty, then you must bear the cost of returning the product.

This warranty gives you specific legal rights and you may also have other rights which vary from state to state.

PITTSBURGH AUTOMOTIVE

3491 Mission Oaks Blvd. • PO Box 6009 • Camarillo, CA 93011 • (800) 444-3353