

DIAL ROUTER SPEED CONTROL

Model 43060

ASSEMBLY AND OPERATING INSTRUCTIONS

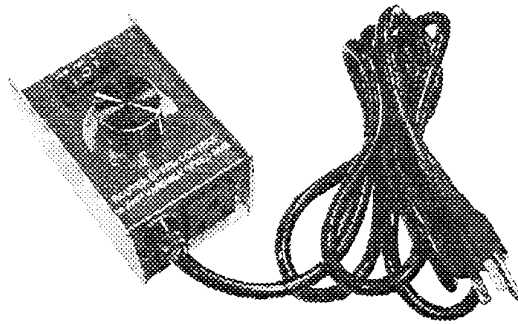

3491 Mission Oaks Blvd., Camarillo, CA 93011

Visit our Web site at <http://www.harborfreight.com>

Copyright © 2000 by Harbor Freight Tools. All rights reserved. No portion of this manual or any artwork contained herein may be reproduced in any shape or form without the express written consent of Harbor Freight Tools.

For technical questions and replacement parts, please call 1-800-444-3353

Specifications

ITEM	DESCRIPTION
Current Capacity	15 amps
Voltage Capacity	250 VDC
Fuse	15 amp
Line Cord	6 feet, 3-wire, double insulated, 18 AWG, U.L. Listed, Plug: 3-pole, American (grounded)
Features	Variable speed or full run
Dimensions	4-3/8 (L) x 2-9/16 (W) x 2-3/4 (H) inches
Weight	0.95 lbs

Save This Manual

You will need the manual for the safety warnings and precautions, assembly instructions, operating and maintenance procedures, parts list and diagram. Keep your invoice with this manual. Write the invoice number on the inside of the front cover. Keep the manual and invoice in a safe and dry place for future reference.

Safety Warnings and Precautions

WARNING: When using tool, basic safety precautions should always be followed to reduce the risk of personal injury and damage to equipment.

Read all instructions before using this product!

1. **Avoid working alone.** If an accident happens, an assistant can bring help.
2. **Avoid electrical shock.** Prevent body contact with grounded surfaces such as pipes, radiators, ranges, and cabinet enclosures.
3. **Keep work area clean.** Cluttered areas invite injuries.
4. **Observe work area conditions.** Do not operate in damp or wet locations. Don't expose to rain. Keep work area well lighted.
5. **Keep children away.** Children must never be allowed in the work area. Do not let them handle machines, tools, or extension cords.
6. **Store idle equipment.** When not in use, tools must be stored in a dry location to inhibit rust. Always lock up tools and keep out of reach of children.

7. **Dress properly.** Do not wear loose clothing or jewelry as they can be caught in moving parts. Protective, electrically nonconductive clothes and nonskid footwear are recommended when working. Wear restrictive hair covering to contain long hair.
8. **Use eye and ear protection.** Always wear ANSI approved impact safety goggles.
9. **Do not overreach.** Keep proper footing and balance at all times. Do not reach over or across electrical cables or frames.
10. **Maintain tools with care.** Inspect tool cords periodically and, if damaged, have them repaired by an authorized technician.
11. **Use the right tool for the job.** Do not attempt to force a small tool or attachment to do the work of a larger industrial tool. There are certain applications for which this tool was designed. Do not modify this tool and do not use this tool for a purpose for which it was not intended.
12. **Stay alert.** Watch what you are doing, use common sense. Do not operate any tool when you are tired.
13. **Check for damaged parts.** Before using any tool, any part that appears damaged should be carefully checked to determine that it will operate properly and perform its intended function. Any part that is damaged should be properly repaired or replaced by a qualified technician. Do not use the tool if any switch does not turn On and Off properly.
14. **Replacement parts and accessories.** When servicing, use only identical replacement parts. Use of any other parts will void the warranty.
15. **Do not operate tool if under the influence of alcohol or drugs.** Read warning labels on prescriptions to determine if your judgment or reflexes are impaired while taking drugs. If there is any doubt, do not operate the tool.
16. **Use proper size and type extension cord.** If an extension cord is required, it must be of the proper size and type to supply the correct current to the tool without heating up. Otherwise, the extension cord could melt and catch fire, or cause electrical damage to the tool. This tool requires use of an extension cord of **0 to 15 amps** capability (up to 50 feet), with wire size rated at **18 AWG**. Longer extension cords require larger size wire. If you are using the tool outdoors, use an extension cord rated for outdoor use. (signified by "WA" on the jacket).
17. **Take caution as some woods contain preservatives such as copper chromium arsenate (CCA) which can be toxic.** When cutting these materials extra care should be taken to avoid inhalation and minimize skin contact.

18. **Maintenance.** For your safety, service and maintenance should be performed regularly by a qualified technician.

Note: Performance of this tool may vary depending on variations in local line voltage. Extension cord usage may also affect tool performance.

Warning: The warnings, cautions, and instructions discussed in this instruction manual cannot cover all possible conditions and situations that may occur. It must be understood by the operator that common sense and caution are factors which cannot be built into this product, but must be supplied by the operator.

Unpacking

When unpacking, check to make sure that all the parts are included. If any parts are missing or broken, please call Harbor Freight Tools at the number on the cover of this manual.

Operation

1. Before using, read and understand all instructions and safety warnings in the instruction manual provided by the manufacturer of the router being used. Verify that the router's Trigger Switch is in the OFF position. Plug the Router's electrical cord into the outlet on the Router Speed Control.

2. Insert the Router Speed Control Plug (18) into an electrical outlet or extension cord (see Safety Precaution # 16 regarding extension cords.).
3. For variable speed control, set the Rocker Switch (8) to VAR and turn the Speed Knob (10) to Low, Medium, or High speed.
4. For full speed operation, set the Rocker Switch (8) to FULL.
5. When ready, press the Router's Trigger Switch to the ON position to begin routing.

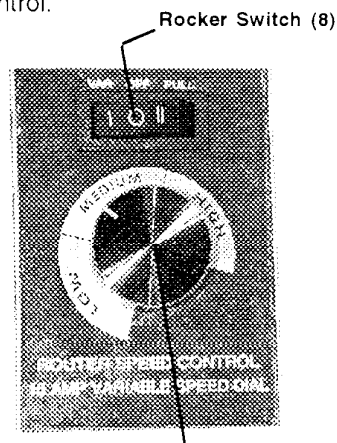

6. During variable speed operation, you can release the Router's Trigger Switch and turn the Speed Knob to another speed, then resume work.
7. When finished, release the Router's Trigger Switch and press the Rocker Switch to the (center) OFF position.
8. Unplug the Router Speed Control from the electrical outlet.

Maintenance

1. Store the Dial Router Speed Control in a clean and dry location.
2. To clean, wipe the unit off with a clean, damp cloth. Never use chemicals or solvents to clean.
3. If the fuse blows, you may be using a tool that uses more current than the Router Speed Control can provide (see Specifications).

Replace with a 15 amp rated fuse.

Parts List

Item #	Description	Qty
1	Fuse Lid	1
2	Fuse	1
3	Fuse Holder	1
4	Washer	1
5	Wire	1
6	Nut	1
7	Face Plate	1
8	Rocker Switch	1
9	Screws	4
10	Speed Knob	1
11	Nut	1
12	Washer	1
13	Potentiometer	1
14	Circuit Board	1
15	Housing	1
16	Rectifier	1
17	Hold Clamp	1
18	Plug	1
19	Outlet Socket	1
20	Cord	1
21	Cord Clamp	1
22	Screws	2

NOTE: Some parts are listed and shown for illustration purposes only and are not available individually as replacement parts.

Assembly Drawing

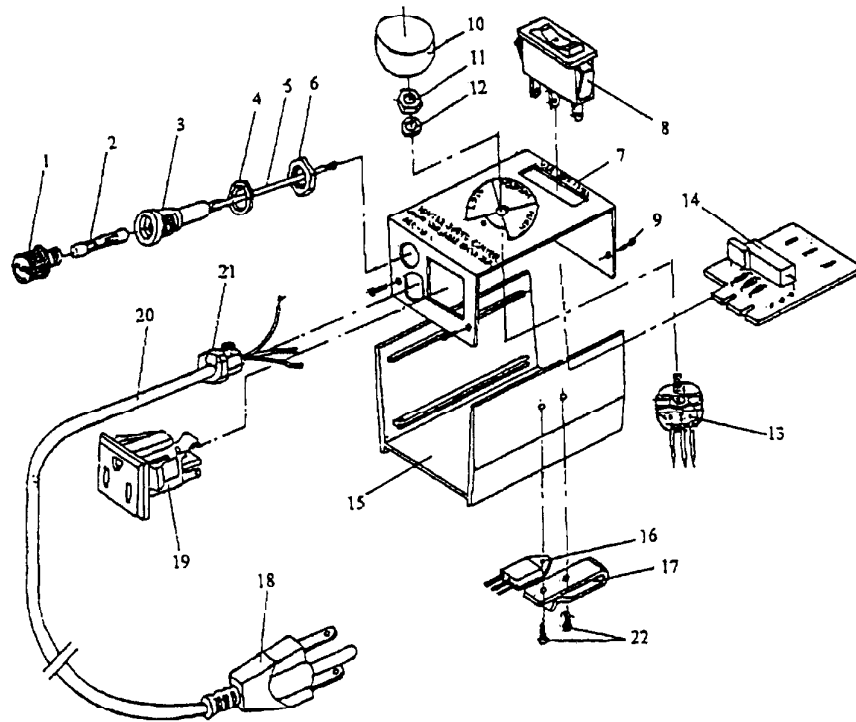

PLEASE READ THE FOLLOWING CAREFULLY

THE MANUFACTURER AND/OR DISTRIBUTOR HAS PROVIDED THE PARTS DIAGRAM IN THIS MANUAL AS A REFERENCE TOOL ONLY. NEITHER THE MANUFACTURER NOR DISTRIBUTOR MAKES ANY REPRESENTATION OR WARRANTY OF ANY KIND TO THE BUYER THAT HE OR SHE IS QUALIFIED TO MAKE ANY REPAIRS TO THE PRODUCT OR THAT HE OR SHE IS QUALIFIED TO REPLACE ANY PARTS OF THE PRODUCT. IN FACT, THE MANUFACTURER AND/OR DISTRIBUTOR EXPRESSLY STATES THAT ALL REPAIRS AND PARTS REPLACEMENTS SHOULD BE UNDERTAKEN BY CERTIFIED AND LICENSED TECHNICIANS AND NOT BY THE BUYER. THE BUYER ASSUMES ALL RISK AND LIABILITY ARISING OUT OF HIS OR HER REPAIRS TO THE ORIGINAL PRODUCT OR REPLACEMENT PARTS THERETO, OR ARISING OUT OF HIS OR HER INSTALLATION OF REPLACEMENT PARTS THERETO.