

# Owner's Manual & Safety Instructions

**Save This Manual** Keep this manual for the safety warnings and precautions, assembly, operating, inspection, maintenance and cleaning procedures. Write the product's serial number in the back of the manual (or month and year of purchase if product has no number). Keep this manual and the receipt in a safe and dry place for future reference.

22b

# CENTRAL<sup>®</sup> MACHINERY

## 30" PEDESTAL HIGH VELOCITY SHOP FAN



**47755**

Visit our website at: <http://www.harborfreight.com>  
Email our technical support at: [productsupport@harborfreight.com](mailto:productsupport@harborfreight.com)





When unpacking, make sure that the product is intact and undamaged. If any parts are missing or broken, please call 1-888-866-5797 as soon as possible.

Copyright© 2020 by Harbor Freight Tools®. All rights reserved.  
No portion of this manual or any artwork contained herein may be reproduced in any shape or form without the express written consent of Harbor Freight Tools. Diagrams within this manual may not be drawn proportionally. Due to continuing improvements, actual product may differ slightly from the product described herein.  
Tools required for assembly and service may not be included.

### **⚠WARNING**

Read this material before using this product.  
Failure to do so can result in serious injury.  
**SAVE THIS MANUAL.**

## WARNING SYMBOLS AND DEFINITIONS

	This is the safety alert symbol. It is used to alert you to potential personal injury hazards. Obey all safety messages that follow this symbol to avoid possible injury or death.
	Indicates a hazardous situation which, if not avoided, will result in death or serious injury.
	Indicates a hazardous situation which, if not avoided, could result in death or serious injury.
	Indicates a hazardous situation which, if not avoided, could result in minor or moderate injury.
	Addresses practices not related to personal injury.

# CENTRAL<sup>®</sup> MACHINERY



**READ AND SAVE THESE INSTRUCTIONS.**

## IMPORTANT SAFETY INFORMATION

1. **WARNING!** To reduce the risk of fire or electric shock, do not use this Fan with any solid-state speed control device.
2. After servicing, any safety device shall be reinstalled or remounted as previously installed.
3. Do not leave Fan running while unattended.
4. Do not operate any fan with a damaged cord or plug. Discard fan or return to an authorized service facility for examination and/or repair.
5. Do not run cord under carpeting. Do not cover cord with throw rugs, runners, or similar coverings. Do not route cord under furniture or appliances. Arrange cord away from traffic area and where it will not be tripped over.
6. Never insert fingers, pencils, or any other object through Front or Rear Blade Guards.
7. Disconnect Fan when moving it from one location to another.
8. Disconnect Fan before removing grills for cleaning.
9. Be sure fan is on a stable surface when operating to avoid overturning.
10. DO NOT use fan in window. Rain may create electrical hazard.
11. Complete the assembly of the fan before switching on the fan.
12. Maintain labels and nameplates on the fan. If unreadable or missing, contact Harbor Freight Tools for a replacement.
13. Use only in dry areas. Do not use in bathrooms, laundry area, near sinks or other sources of water.
14. This fan is not a toy. Keep it out of reach of children.
15. People with pacemakers should consult their physician(s) before use. Electromagnetic fields in close proximity to heart pacemaker could cause pacemaker interference or pacemaker failure.
16. The warnings, precautions, and instructions discussed in this instruction manual cannot cover all conditions and situations that may occur. It must be understood by operator that common sense and caution are factors which cannot be built into this fan, but must be supplied by operator.

## Specifications

Electrical Requirements	120 VAC / 60 Hz / 2.4 A
Speeds	Low: ~900 RPM Medium: ~1,030 RPM High: ~1,080 RPM

**Suitable for Commercial or Industrial Use Only**

**CENTRAL<sup>®</sup>**  
**MACHINERY**

# Assembly



Read the **ENTIRE RULES FOR SAFE OPERATION** section at the beginning of this manual including all text under subheadings therein before set up or use of this product.

## WARNING

**TO PREVENT SERIOUS INJURY FROM ACCIDENTAL OPERATION OR ELECTRIC SHOCK:**

Before assembly, cleaning or adjustment, make sure the switch is turned off, the cord is unplugged, and the unit has cooled.

**Note:** For additional information regarding parts listed, refer to Parts List and Diagram.

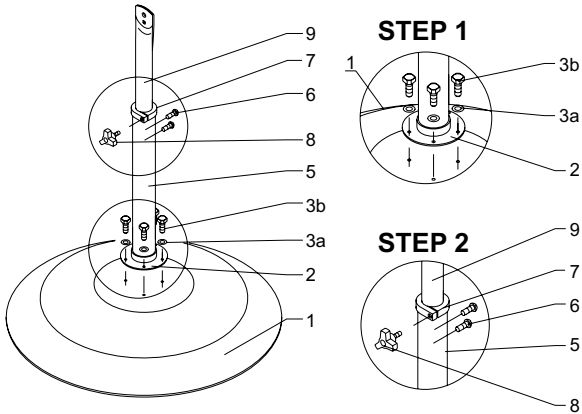

1. Attach the Coupler (2) to the Base (1) using Bolts (3b) and Washers (3a), as shown.
2. Loosen the Height Knob (8). Extend the Extension Pole (9) to the desired height and tighten the Knob fully.

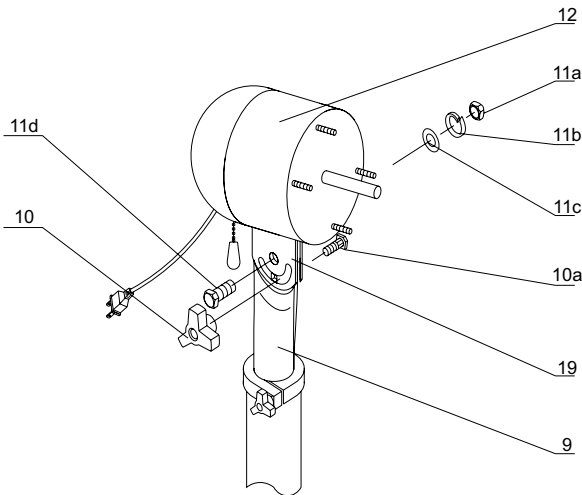

**STEPS 3 & 4**

3. Slide the Motor Flange (19) over the top of the Extension Pole (9). Insert the Bolt (11d) through the hole in the center of the Flange and Pole and secure it with Washer (11c), Lock Washer (11b), and Nut (11a).

4. Insert the Carriage Bolt (10a) through the lower slot as shown. The square portion of the Bolt should prevent it from turning. Thread the Angle Knob (10) onto the Carriage Bolt and tighten it firmly to secure the Motor (12) in place.
5. Remove the Nuts and Washers (13a, 13b, & 13c) from the front of the Motor (12).

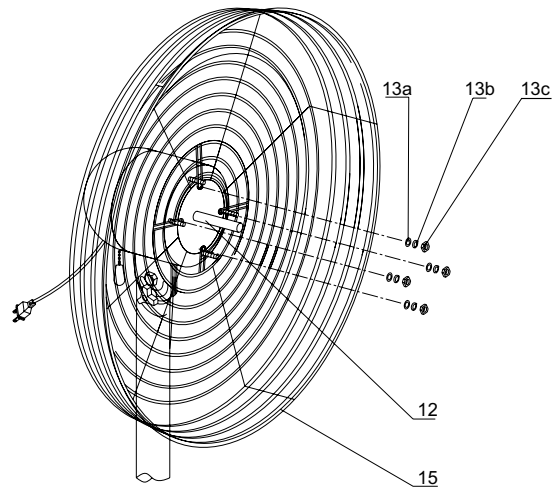

**STEP 6**

6. Position Rear Grill (15) over exposed studs as shown. Secure with Washers (13a), Lock Washers (13b), and Nuts (13c).
7. Loosen Set Screw (14) on the side of Blade (16).

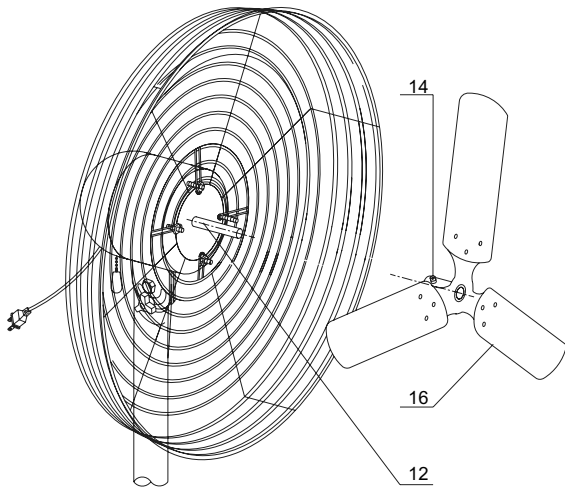

### STEP 8

8. Line up the Set Screw (14) with the flat side of the Motor (12) shaft. Slide the Blade (16) all the way onto the Motor shaft with the Set Screw side first.
9. **Securely** tighten the Set Screw (14) on the side of the Blade (16).
10. Swing all hinged clips on the Front Grill (17) out.

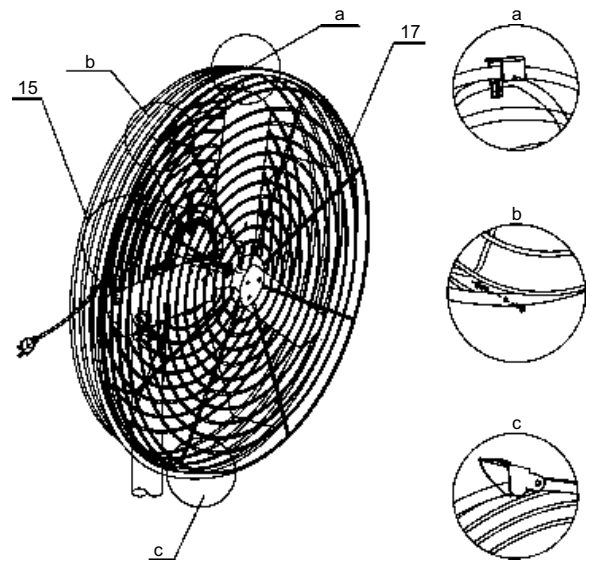

### STEP 11

11. Attach the Front Grill (17) as follows:
  - a. Hang the Front Grill on the Rear Grill (15) using the hanger at the top.
  - b. Attach the two Grills to each other using the Grill Screw (20).
  - c. Swing all hinged clips down over the edge of the guard.
  - d. Double-check that the guard is assembled securely and properly.
12. Assembly is complete. Check all connections before plugging in or operating the fan.

# CENTRAL<sup>®</sup>

## MACHINERY

## Operation



Read the **ENTIRE RULES FOR SAFE OPERATION** section at the beginning of this manual including all text under subheadings therein before set up or use of this product.

1. Pull the chain on the Motor (12) to turn on the fan and cycle through low-medium-high-off settings.

**CAUTION!** Motor housing will get hot during normal operation. To prevent injury, do not touch. Do not cover motor housing.

2. To adjust the fan's angle:
  - a. Unplug the fan and allow it to stop.
  - b. Loosen the Bolt (11d) and the Angle Knob (10).
  - c. Adjust the fan's angle, then retighten the Bolt and Angle Knob securely and plug in the fan before further use.

3. To adjust the fan's height:
  - a. Unplug the fan and allow it to stop.
  - b. Loosen the Height Knob (8).
  - c. Adjust the Extension Pole (9) to the desired height.

**WARNING!** TO PREVENT SERIOUS INJURY: Do not over-extend the Extension Pole. Over-extension can cause the pole assembly to fall apart.

- d. Tighten the Height Knob securely and plug in the fan before further use.

## Inspection and Maintenance

### **⚠ DANGER**

**AUTOMATIC RESET SAFETY DEVICE IN MOTOR. TO REDUCE RISK OF INJURY DISCONNECT POWER SUPPLY BEFORE SERVICING.**

### **⚠ WARNING**

**TO PREVENT SERIOUS INJURY FROM ACCIDENTAL OPERATION OR ELECTRIC SHOCK:**

Before appliance inspection or maintenance, make sure the appliance's switch is turned off, the cord is unplugged, and the unit has cooled completely.

**TO PREVENT SERIOUS INJURY FROM APPLIANCE FAILURE:**

**Do not use damaged appliances. If abnormal noise or vibration occurs, have the problem corrected before further use.**

1. **BEFORE EACH USE**, inspect condition of the Fan. Check for loose screws, misalignment or binding of moving parts, cracked or broken parts, and any other condition that may affect its safe operation.
2. Clean regularly to prevent dust from accumulating on Blade. **Automatic reset safety device in motor. To reduce risk of injury disconnect power supply before servicing.** Use damp cloth during cleaning and dry before use.

## PLEASE READ THE FOLLOWING CAREFULLY

THE MANUFACTURER AND/OR DISTRIBUTOR HAS PROVIDED THE PARTS LIST AND ASSEMBLY DIAGRAM IN THIS MANUAL AS A REFERENCE TOOL ONLY. NEITHER THE MANUFACTURER OR DISTRIBUTOR MAKES ANY REPRESENTATION OR WARRANTY OF ANY KIND TO THE BUYER THAT HE OR SHE IS QUALIFIED TO MAKE ANY REPAIRS TO THE PRODUCT, OR THAT HE OR SHE IS QUALIFIED TO REPLACE ANY PARTS OF THE PRODUCT. IN FACT, THE MANUFACTURER AND/OR DISTRIBUTOR EXPRESSLY STATES THAT ALL REPAIRS AND PARTS REPLACEMENTS SHOULD BE UNDERTAKEN BY CERTIFIED AND LICENSED TECHNICIANS, AND NOT BY THE BUYER. THE BUYER ASSUMES ALL RISK AND LIABILITY ARISING OUT OF HIS OR HER REPAIRS TO THE ORIGINAL PRODUCT OR REPLACEMENT PARTS THERETO, OR ARISING OUT OF HIS OR HER INSTALLATION OF REPLACEMENT PARTS THERETO.

**Record Product's Serial Number Here:** \_\_\_\_\_

**Note:** If product has no serial number, record month and year of purchase instead.

**Note:** Some parts are listed and shown for illustration purposes only, and are not available individually as replacement parts. Specify UPC 792363477550 when ordering parts.

# Parts List and Diagram

Part	Description	Qty.
1	Base	1
2	Coupler	1
3a	Washer	5
3b	Screw	5
5	Stand Pole	1
6	Screw	2
7	Adjuster	1
8	Height Knob	1
9	Extension Pole	1
10	Angle Knob	1
10a	Carriage Bolt	1
11a	Nut	1
11b	Lock washer	1
11c	Washer	1

Part	Description	Qty.
11d	Bolt	1
12	Motor	1
13a	Washer	4
13b	Lock Washer	4
13c	Nut	4
14	Set Screw	1
15	Rear Grill	1
16	Blade	1
17	Front Grill	1
18	Power Cord	1
19	Motor Flange	1
20	Grill Screw (not shown)	1

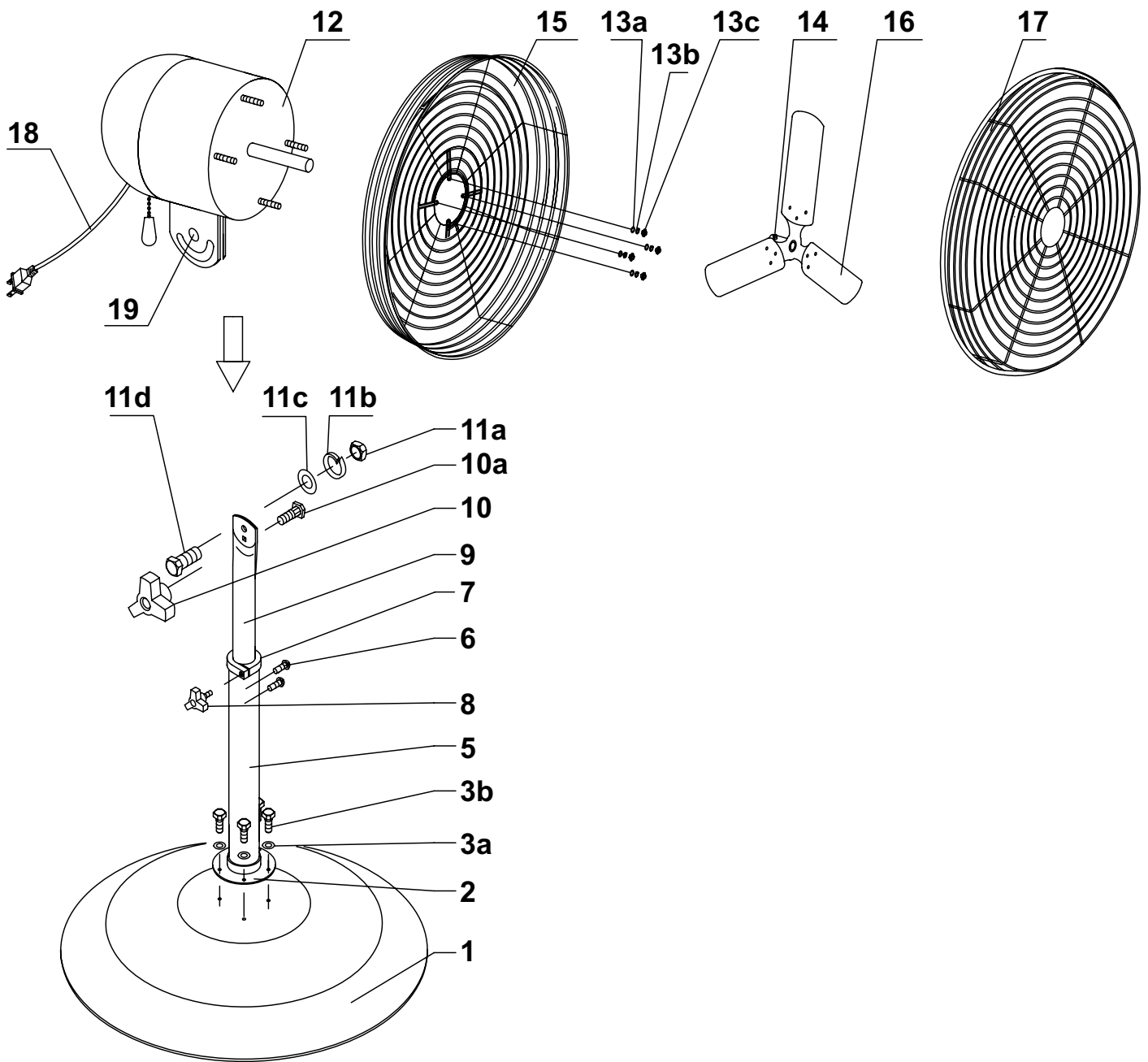

## Limited 90 Day Warranty

Harbor Freight Tools Co. makes every effort to assure that its products meet high quality and durability standards, and warrants to the original purchaser that this product is free from defects in materials and workmanship for the period of 90 days from the date of purchase. This warranty does not apply to damage due directly or indirectly, to misuse, abuse, negligence or accidents, repairs or alterations outside our facilities, criminal activity, improper installation, normal wear and tear, or to lack of maintenance. We shall in no event be liable for death, injuries to persons or property, or for incidental, contingent, special or consequential damages arising from the use of our product. Some states do not allow the exclusion or limitation of incidental or consequential damages, so the above limitation of exclusion may not apply to you. THIS WARRANTY IS EXPRESSLY IN LIEU OF ALL OTHER WARRANTIES, EXPRESS OR IMPLIED, INCLUDING THE WARRANTIES OF MERCHANTABILITY AND FITNESS.

To take advantage of this warranty, the product or part must be returned to us with transportation charges prepaid. Proof of purchase date and an explanation of the complaint must accompany the merchandise. If our inspection verifies the defect, we will either repair or replace the product at our election or we may elect to refund the purchase price if we cannot readily and quickly provide you with a replacement. We will return repaired products at our expense, but if we determine there is no defect, or that the defect resulted from causes not within the scope of our warranty, then you must bear the cost of returning the product.

This warranty gives you specific legal rights and you may also have other rights which vary from state to state.

**CENTRAL<sup>®</sup>**  
**MACHINERY**

26677 Agoura Road • Calabasas, CA 91302 • 1-888-866-5797