



7 PIECE TUBE FLARING KIT

Model 5969

SET UP AND OPERATING INSTRUCTIONS



Diagrams within this manual may not be drawn proportionally.

Due to continuing improvements, actual product may differ slightly from the product described herein.

Distributed exclusively by Harbor Freight Tools®.

3491 Mission Oaks Blvd., Camarillo, CA 93011

Visit our website at: <http://www.harborfreight.com>



**Read this material before using this product.
Failure to do so can result in serious injury.
SAVE THIS MANUAL.**

Copyright© 2003 by Harbor Freight Tools®. All rights reserved. No portion of this manual or any artwork contained herein may be reproduced in any shape or form without the express written consent of Harbor Freight Tools.

For technical questions or replacement parts, please call 1-800-444-3353.

Cover revised 071

THANK YOU for choosing a **HARBOR FREIGHT TOOLS** product. For future reference, please complete the owner's record below:

Model _____ Serial No. _____ Purchase Date _____

SAVE THE RECEIPT, WARRANTY AND THESE INSTRUCTIONS. It is important that you read the entire manual to become familiar with the unit BEFORE you begin assembly.

TECHNICAL SPECIFICATIONS

Construction	Heat treated Tube Cutter with deburrer
2 Piece Flaring Kit Size Range	3/16", 1/4", 5/16", 3/8", 1/2", and 5/8"
Tubing Cutter Capacity	1-1/4"
Flexible Tube Benders	1/4", 5/16", 3/8", 1/2"



IMPORTANT SAFETY INSTRUCTIONS!



READ ALL INSTRUCTIONS BEFORE USING THIS PRODUCT!

SAFETY WARNINGS AND PRECAUTIONS

WARNING: When using product, basic safety precautions should always be followed to reduce the risk of personal injury and damage to equipment.

Read all instructions before using this product!

1. **Keep work area clean.** Cluttered areas invite injuries.
2. **Observe work area conditions.** Keep work area well lighted.
3. **Store idle equipment.** When not in use, the Tube Flaring Kit must be stored in a dry location to inhibit damage from moisture and salt air.
4. **Check for damaged parts.** Before using the Tube Flaring Kit, any part that appears damaged should be carefully checked to determine that it will operate properly and perform its intended function. Check for any broken or damaged parts and any other conditions that may affect its operation. Replace or repair damaged or worn parts immediately.
5. **Replacement parts and accessories.** When servicing, use only identical replacement parts. Use of any other parts will void the warranty.
6. **Do not force product.** Do not use inappropriate attachments in an attempt to exceed the Tube Flaring Kit capacity.
7. **Use the right product for the job.** Do not attempt to force a small product or attachment to do the work of a larger industrial product. There are certain applications for

which this Tube Flaring Kit was designed. Do not modify this Flaring Kit and do not use this ramp for a purpose for which it was not intended.

8. **Use eye protection.** Always wear ANSI approved impact safety goggles when assembling and using this product.
9. **Dress properly.** Do not wear loose clothing or jewelry as they can be caught in moving parts. Wear restrictive hair covering to contain long hair. Wear gloves to protect from burrs and sharp edges.
10. **Keep children away.** Children must never be allowed in the work area.
11. **The warnings, cautions, and instructions discussed in this instruction manual cannot cover all possible conditions and situations that may occur.** It must be understood by the operator that common sense and caution are factors which cannot be built into this product, but must be supplied by the operator.

ASSEMBLY AND OPERATION

Your 7-Piece Tube Flaring Kit will require some light assembly prior to use. It is important that you read the entire manual to become familiar with the Tube Flaring Kit BEFORE you use the Tube Flaring Kit. Before assembling and using the 7-Piece Tube Flaring Kit be sure that you have all parts described in the Parts List and Assembly Diagram located on the last pages of this manual.

Note: Tools in this Kit can be used with the following materials: lightweight steel, copper and aluminum tubing.

Tube Benders

Use the Tube Benders to reduce the risk of stretching and flattening a tube that is to be bent. Always wear ANSI approved safety glasses and a full face shield to protect yourself from injury.

1. Locate the tubing that you wish to bend. Remember that the longer the piece of tubing; the easier it is to bend. The larger the diameter, the longer the excess length should be. Allow an extra 12" on each end of tubing up to 3/4" in diameter.
2. Select the appropriate Tube Bender (4,5,6,7). The Tube Benders come in four different sizes, 1/4" (4), 5/16" (5), 3/8" (6) and 1/2" (7). Slide the Tube Bender (4,5,6,7) over the portion of the tube that is to be bent-see Figure A.
3. Use a large vise that is firmly clamped to a bench or table to clamp the tube in the Tube Bender (4,5,6,7). You may wish to form a jig to bend the tube around. Clamp the jig in the vise. Grab the tubing at each end and apply pressure.

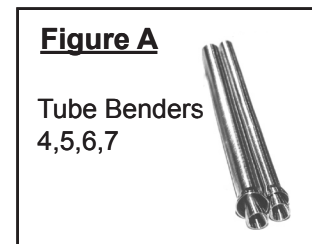

Note: The larger the object over which you are bending the tube, the less chance of flattening the tube where it is bent.

Using the Tubing Cutter

1. Tighten the tubing that you wish to cut in a vise. If needed, measure and mark the tubing before cutting. Make certain that the vise used is firmly anchored to a worktable or bench. It must be able to support the weight of the tubing, along with the pressure that will be applied in the following steps. Do not exceed the 1-1/4" tube cutting capacity.
2. Turn the Knob (1) on the Tubing Cutter counterclockwise until the Cutter Wheel (2) and Blade (3) can be placed over the tube you wish to cut.
3. Turn the Knob (1) clockwise until the Blade (3) begins to cut into the tube. Check to make certain that the cut will be square.
4. Spin the Tubing Cutter around the tubing while turning the Knob (1) counterclockwise and bringing the blade tighter against the tubing. Continue to do this, making sure that the cut is straight along the desired cutting line - see Figure 1.
5. Once the tube has been fully cut, use the Deburrer (8) to remove any burrs and smooth out the edge of the tube.

Flaring Kit

1. Slide the Flare Nut (9) onto the tube-see Figure 2. Turn the Die Handle (10) and open the Flaring Tool.
2. Insert the end of the tube into the hole which corresponds to the tube size. The die has six sizes: 3/16", 1/4", 5/16", 3/8", 1/2", and 5/8".
3. The amount the tubing extends above the Die Block (13) will be the finished diameter of the flare. Make certain that the flare is seated properly against the fitting and that the Flare Nut (9) will fit over it.
4. Tighten the Die Handle (10) to lock the tubing in place. Set the Flaring Tool (12) on the tubing and turn it so that it is secure against the Die Block (13). Turn Flaring Handle (11) until the desired flare is achieved.

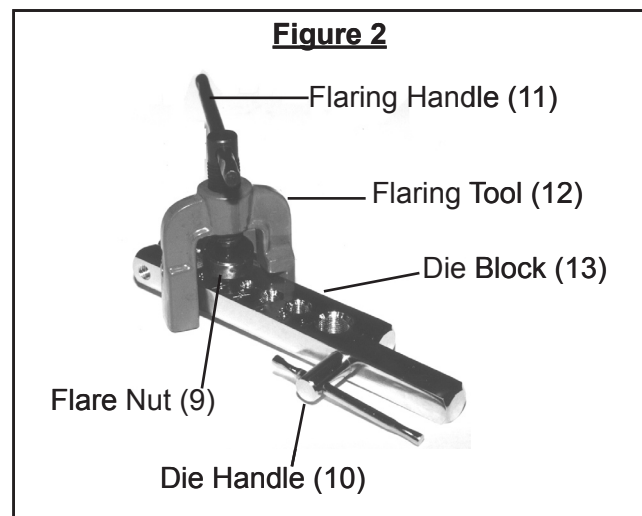
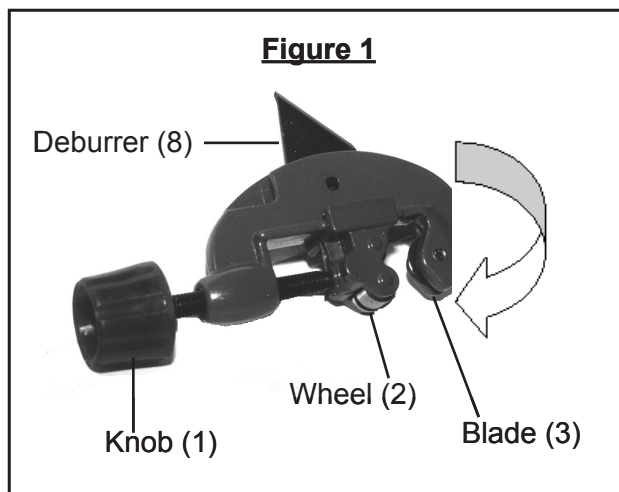

UNPACKING

When unpacking your 7-Piece Tube Flaring Kit, check to make sure the following parts are included. If any parts are missing or broken, please call **HARBOR FREIGHT TOOLS** at **1-800-444-3353**.

PARTS LIST

Part	Description	Q'ty
1	Knob	1
2	Wheel	1
3	Blade	1
4	1/4" Tube Bender	1
5	5/16" Tube Bender	1
6	3/8" Tube Bender	1
7	1/2" Tube Bender	1

Part	Description	Q'ty
8	Deburrer	1
9	Flare Nut	1
10	Die Handle	1
11	Flaring Handle	1
12	Flaring Tool	1
13	Die Block	1

Note: Some parts are listed and shown for illustration purposes only and are not available individually as replacement parts.

ASSEMBLY/PARTS DIAGRAM

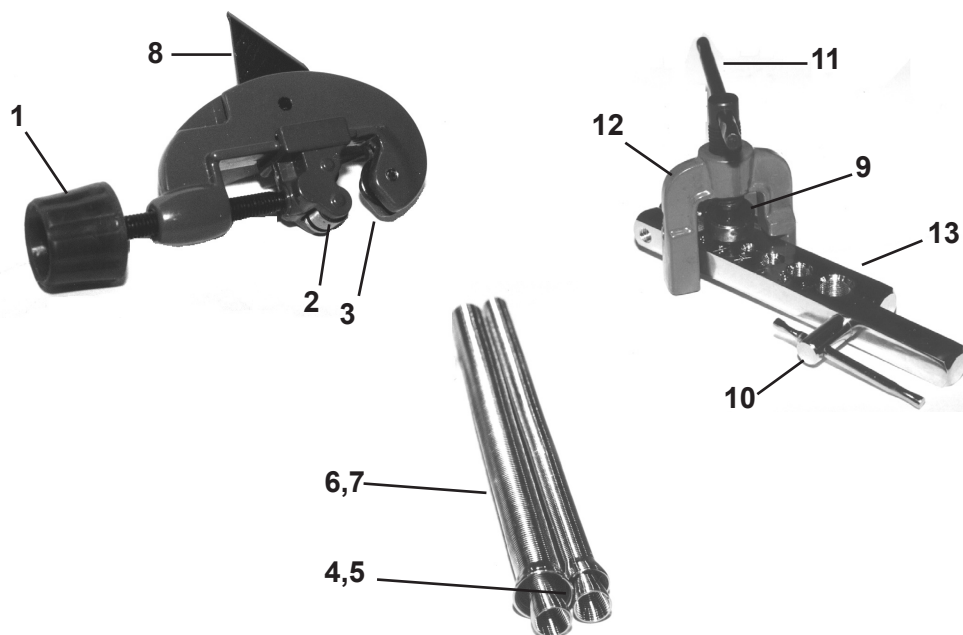

PLEASE READ THE FOLLOWING CAREFULLY

THE MANUFACTURER AND/OR DISTRIBUTOR HAS PROVIDED THE PARTS DIAGRAM IN THIS MANUAL AS A REFERENCE TOOL ONLY. NEITHER THE MANUFACTURER NOR DISTRIBUTOR MAKES ANY REPRESENTATION OR WARRANTY OF ANY KIND TO THE BUYER THAT HE OR SHE IS QUALIFIED TO MAKE ANY REPAIRS TO THE PRODUCT OR THAT HE OR SHE IS QUALIFIED TO REPLACE ANY PARTS OF THE PRODUCT. IN FACT, THE MANUFACTURER AND/OR DISTRIBUTOR EXPRESSLY STATES THAT ALL REPAIRS AND PARTS REPLACEMENTS SHOULD BE UNDERTAKEN BY CERTIFIED AND LICENSED TECHNICIANS AND NOT BY THE BUYER. THE BUYER ASSUMES ALL RISK AND LIABILITY ARISING OUT OF HIS OR HER REPAIRS TO THE ORIGINAL PRODUCT OR REPLACEMENT PARTS THERETO, OR ARISING OUT OF HIS OR HER INSTALLATION OF REPLACEMENT PARTS THERETO.

LIMITED 90 DAY WARRANTY

Harbor Freight Tools Co. makes every effort to assure that its products meet high quality and durability standards, and warrants to the original purchaser that this product is free from defects in materials and workmanship for the period of 90 days from the date of purchase. This warranty does not apply to damage due directly or indirectly, to misuse, abuse, negligence or accidents, repairs or alterations outside our facilities, criminal activity, improper installation, normal wear and tear, or to lack of maintenance. We shall in no event be liable for death, injuries to persons or property, or for incidental, contingent, special or consequential damages arising from the use of our product. Some states do not allow the exclusion or limitation of incidental or consequential damages, so the above limitation of exclusion may not apply to you. THIS WARRANTY IS EXPRESSLY IN LIEU OF ALL OTHER WARRANTIES, EXPRESS OR IMPLIED, INCLUDING THE WARRANTIES OF MERCHANTABILITY AND FITNESS.

To take advantage of this warranty, the product or part must be returned to us with transportation charges prepaid. Proof of purchase date and an explanation of the complaint must accompany the merchandise. If our inspection verifies the defect, we will either repair or replace the product at our election or we may elect to refund the purchase price if we cannot readily and quickly provide you with a replacement. We will return repaired products at our expense, but if we determine there is no defect, or that the defect resulted from causes not within the scope of our warranty, then you must bear the cost of returning the product.

This warranty gives you specific legal rights and you may also have other rights which vary from state to state.

3491 Mission Oaks Blvd. • PO Box 6009 • Camarillo, CA 93011 • (800) 444-3353