

Owner's Manual & Safety Instructions

Save This Manual Keep this manual for the safety warnings and precautions, assembly, operating, inspection, maintenance and cleaning procedures. Write the product's serial number in the back of the manual near the assembly diagram (or month and year of purchase if product has no number). Keep this manual and the receipt in a safe and dry place for future reference.

19g

PITTSBURGH[®] AUTOMOTIVE

56383

Heavy Duty Creeper with Adjustable Headrest



Visit our website at: <http://www.harborfreight.com>
Email our technical support at: productsupport@harborfreight.com

When unpacking, make sure that the product is intact and undamaged. If any parts are missing or broken, please call 1-888-866-5797 as soon as possible.

Copyright© 2019 by Harbor Freight Tools®. All rights reserved.
No portion of this manual or any artwork contained herein may be reproduced in any shape or form without the express written consent of Harbor Freight Tools. Diagrams within this manual may not be drawn proportionally. Due to continuing improvements, actual product may differ slightly from the product described herein. Tools required for assembly and service may not be included.

⚠ WARNING

Read this material before using this product. Failure to do so can result in serious injury. **SAVE THIS MANUAL.**

Specifications

Maximum Weight Capacity	250 lb
-------------------------	--------

IMPORTANT SAFETY INFORMATION

1. Keep work area clean and well lit. Cluttered or dark areas invite accidents.
2. Do not use Creeper when you are tired or under the influence of alcohol or drugs.
3. Do not work under a vehicle raised on a jack. Support vehicle on jack stands (not included). Block any tires that will remain on the ground.
4. If the vehicle is on the ground, block the tires, set the parking brake, and put it in gear or park.
5. This product is not a toy. Do not allow children to play with or near this item.
6. Use as intended only. Do not stand on creeper.
7. Store on edge, clear of walkways when not in use.
8. Inspect before every use; do not use if parts are loose or damaged.
9. Do not exceed maximum weight capacity. **Be aware of dynamic loading!** Suddenly dropping onto creeper may briefly create excess load causing product failure.
10. Use on flat, level, hard surface only.
11. Maintain product labels and nameplates. These carry important safety information. If unreadable or missing, contact Harbor Freight Tools for a replacement.

Operation Instructions



Read the **ENTIRE IMPORTANT SAFETY INFORMATION** section at the beginning of this manual including all text under subheadings therein before set up or use of this product.

WARNING

TO PREVENT SERIOUS INJURY:

Do not work under a vehicle raised on a jack. Support vehicle on jack stands (not included). Block any tires that will remain on the ground. If the vehicle is on the ground, block the tires, set the parking brake, and put it in gear or Park.

1. Lay the Head Cushion (2) flat using the Adjustment Lever (8).
 - a. To adjust the Head Cushion, disengage the lever from the teeth of the Stop Plate (9).
 - b. Simultaneously use one hand to pull up on the Head Cushion, while using a second hand to push the Adjustment Lever down and back.
2. Keep your head flat on the Head Cushion while sliding under the vehicle. Then, pull the Head Cushion into a comfortable angle.
3. Lay the Head Cushion flat to slide the Creeper out.

Maintenance



Procedures not specifically explained in this manual must be performed only by a qualified technician.

1. Wipe down cushions with a damp cloth.
2. Clean off any grease or debris which accumulates on casters.
3. Check hardware and tighten if necessary.

Parts List and Diagram

Part	Description	Qty
1	Frame	1
2	Head Cushion	1
3	Body Cushion	1
4	Plug	4
5	Nut	6
6	Spring Washer	6
7	Caster	6

Part	Description	Qty
8	Adjustment Lever	1
9	Stop Plate	1
10	Cover Plate	1
11	Hinge	1
12	Bolt M6 short	2
13	Bolt M6 medium	4
14	Bolt M6 long	2

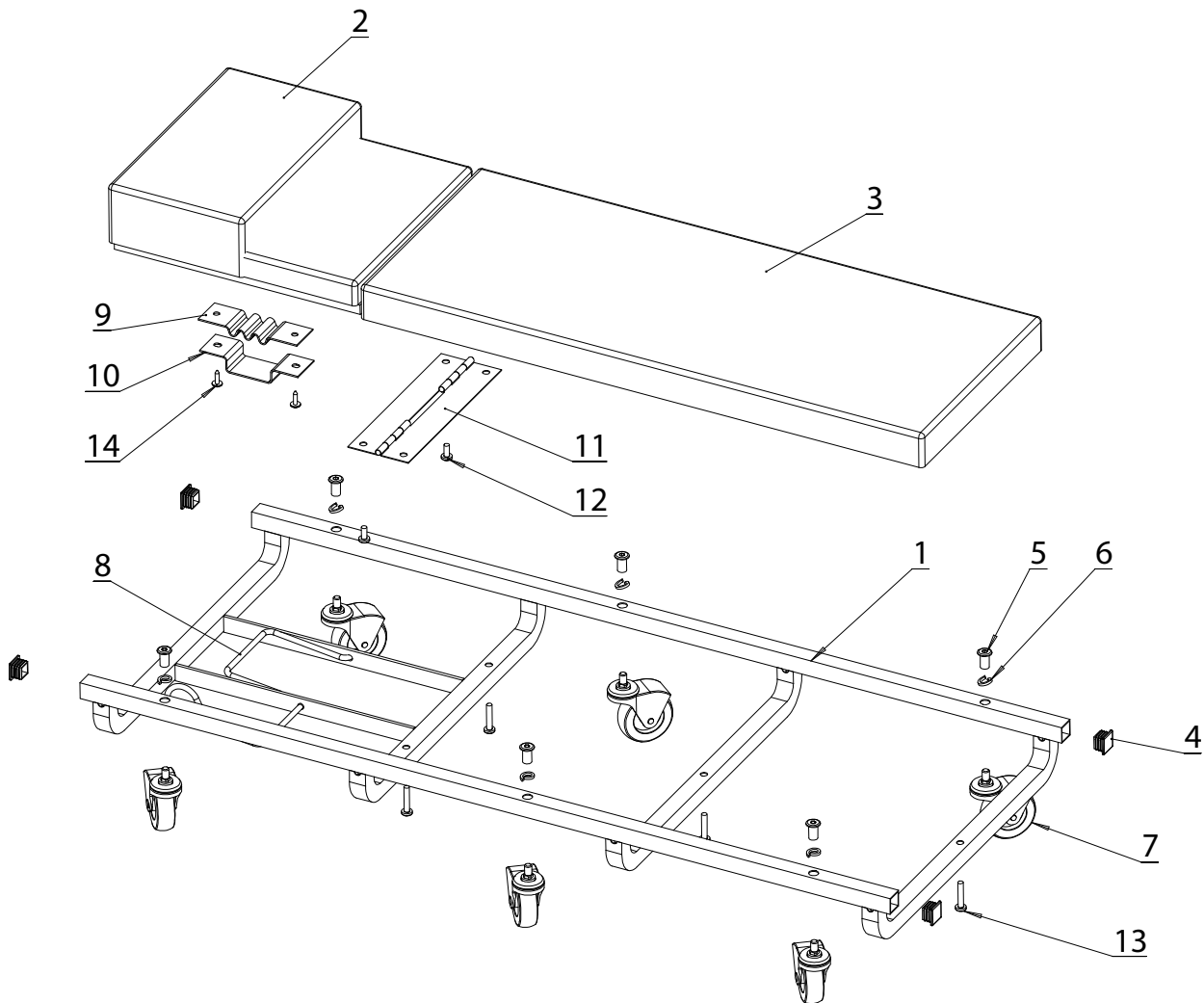

Record Serial Number Here:

Note: If product has no serial number, record month and year of purchase instead.

Note: Some parts are listed and shown for illustration purposes only, and are not available individually as replacement parts.

PLEASE READ THE FOLLOWING CAREFULLY

THE MANUFACTURER AND/OR DISTRIBUTOR HAS PROVIDED THE PARTS LIST AND ASSEMBLY DIAGRAM IN THIS DOCUMENT AS A REFERENCE TOOL ONLY. NEITHER THE MANUFACTURER OR DISTRIBUTOR MAKES ANY REPRESENTATION OR WARRANTY OF ANY KIND TO THE BUYER THAT HE OR SHE IS QUALIFIED TO MAKE ANY REPAIRS TO THE PRODUCT, OR THAT HE OR SHE IS QUALIFIED TO REPLACE ANY PARTS OF THE PRODUCT. IN FACT, THE MANUFACTURER AND/OR DISTRIBUTOR EXPRESSLY STATES THAT ALL REPAIRS AND PARTS REPLACEMENTS SHOULD BE UNDERTAKEN BY CERTIFIED AND LICENSED TECHNICIANS, AND NOT BY THE BUYER. THE BUYER ASSUMES ALL RISK AND LIABILITY ARISING OUT OF HIS OR HER REPAIRS TO THE ORIGINAL PRODUCT OR REPLACEMENT PARTS THERETO, OR ARISING OUT OF HIS OR HER INSTALLATION OF REPLACEMENT PARTS THERETO.

Limited 90 Day Warranty

Harbor Freight Tools Co. makes every effort to assure that its products meet high quality and durability standards, and warrants to the original purchaser that this product is free from defects in materials and workmanship for the period of 90 days from the date of purchase. This warranty does not apply to damage due directly or indirectly, to misuse, abuse, negligence or accidents, repairs or alterations outside our facilities, criminal activity, improper installation, normal wear and tear, or to lack of maintenance. We shall in no event be liable for death, injuries to persons or property, or for incidental, contingent, special or consequential damages arising from the use of our product. Some states do not allow the exclusion or limitation of incidental or consequential damages, so the above limitation of exclusion may not apply to you. THIS WARRANTY IS EXPRESSLY IN LIEU OF ALL OTHER WARRANTIES, EXPRESS OR IMPLIED, INCLUDING THE WARRANTIES OF MERCHANTABILITY AND FITNESS.

To take advantage of this warranty, the product or part must be returned to us with transportation charges prepaid. Proof of purchase date and an explanation of the complaint must accompany the merchandise. If our inspection verifies the defect, we will either repair or replace the product at our election or we may elect to refund the purchase price if we cannot readily and quickly provide you with a replacement. We will return repaired products at our expense, but if we determine there is no defect, or that the defect resulted from causes not within the scope of our warranty, then you must bear the cost of returning the product.

This warranty gives you specific legal rights and you may also have other rights which vary from state to state.

PITTSBURGH[®] AUTOMOTIVE

26541 Agoura Road • Calabasas, CA 91302 • 1-888-866-5797