

Owner's Manual & Safety Instructions

Save This Manual Keep this manual for the safety warnings and precautions, assembly, operating, inspection, maintenance and cleaning procedures. Write the product's serial number in the back of the manual near the assembly diagram (or month and year of purchase if product has no number). Keep this manual and the receipt in a safe and dry place for future reference.

191



30" 2-DRAWER STORAGE CART



56812

Visit our website at: <http://www.harborfreight.com>
Email our technical support at: productsupport@harborfreight.com

When unpacking, make sure that the product is intact and undamaged. If any parts are missing or broken, please call 1-888-866-5797 as soon as possible.

Copyright© 2019 by Harbor Freight Tools®. All rights reserved.
No portion of this manual or any artwork contained herein may be reproduced in any shape or form without the express written consent of Harbor Freight Tools. Diagrams within this manual may not be drawn proportionally. Due to continuing improvements, actual product may differ slightly from the product described herein.
Tools required for assembly and service may not be included.

⚠ WARNING

Read this material before using this product.
Failure to do so can result in serious injury.
SAVE THIS MANUAL.

Specifications

| | |
|---|---------------|
| Total Combined Weight Capacity (Evenly distributed from bottom up) | 550 lb |
|---|---------------|



IMPORTANT SAFETY INFORMATION

Assembly Precautions

1. Assemble only according to these instructions. Improper assembly can create hazards.
2. Wear ANSI-approved safety goggles and heavy-duty work gloves during assembly.
3. Keep assembly area clean and well lit.
4. Keep bystanders out of the area during assembly.
5. Do not assemble when tired or when under the influence of alcohol, drugs or medication.
6. Weight capacity and other product capabilities apply to properly and completely assembled product only.
7. Assemble on a flat, level, hard and smooth surface capable of safely supporting loaded Cart.

Use Precautions

TO PREVENT SERIOUS INJURY AND DEATH FROM TIPPING:

1. **DO NOT SIT, STAND OR CLIMB ON THIS ITEM.**
2. This product is not a toy nor a toy chest. Do not allow children to play with or near this item.
3. Do not exceed 550 lb total weight capacity, evenly distributed from bottom up.
Be aware of dynamic loading!
Sudden load movement may briefly create excess load causing product failure.
4. Lid must be open for Drawer to be unlocked.
5. Close Lid to lock Drawer, then lock Lid with Key before moving.
6. Use only on a flat, level, hard and smooth surface capable of safely supporting a fully loaded Cart. Do not roll Cart over concrete seams or other rough/uneven surfaces.
7. Do not lift using handle(s). Do not lift while loaded.
8. Lock Swivel Casters after moving.
9. Do not mount on truck bed or any other moving object.
10. Use as intended only.
11. Inspect before every use; do not use if parts are loose or damaged.
12. Maintain product labels and nameplates. These carry important safety information. If unreadable or missing, contact Harbor Freight Tools for a replacement.



Assembly Instructions



Read the **ENTIRE IMPORTANT SAFETY INFORMATION** section at the beginning of this document including all text under subheadings therein before set up or use of this product.

Note: Finger tighten hardware until assembly is complete.

1. Assemble on a flat, level, hard and smooth surface capable of safely supporting a fully loaded Cart.
2. Attach two Fixed Casters (14) to one side of the Bottom Shelf (12) using eight sets of Caster Bolts (13), Washers (3) and Nuts (4).

Note: Caster Bolts (13) have hex heads. Handle Bolts (9) are slightly longer than other Bolts (2).

3. Attach two Locking Swivel Casters (11) to other side, using eight sets of Caster Bolts, Washers and Nuts.
4. For the left side, attach a Cross Support (10) between one each Right-handed Post (1) and Left-handed Post (6), using two sets of Bolts (2), Washers and Nuts.

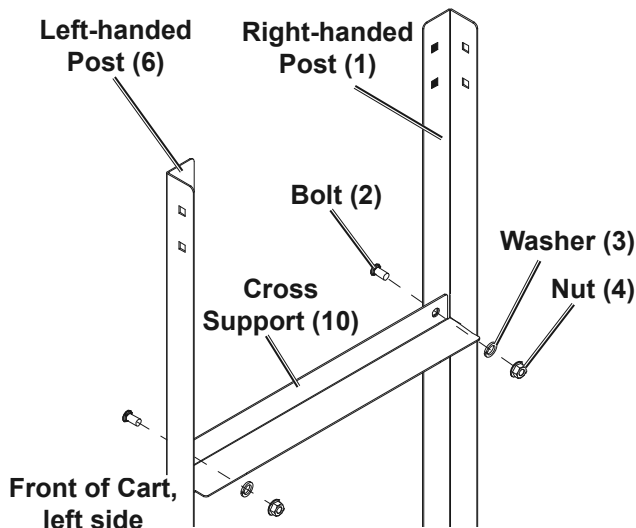

5. Repeat for the right side.

Note: Assemble Right-handed Post (1) in front on the right side and Left-handed Post (6) in front on the left side. See Diagram on page 7.

6. Lock Swivel Casters.
7. Attach Post assemblies to the outside corners of the Bottom Shelf, using sixteen sets of Bolts, Washers and Nuts.

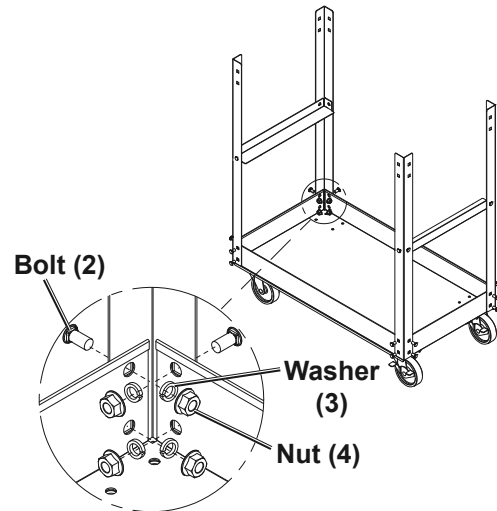

WARNING! The Chest (5) is heavy. Do not attempt to lift and lower onto Cross Supports without assistance. Support the Chest fully until it is completely secured to the Posts.

8. With assistance, lift up the Chest, then lower it carefully between the Posts until its bottom edges rest on the Cross Supports.
9. Attach the Handle (7) to lower holes on the same side as Locking Swivel Casters, using two sets of Handle Bolts (9), Washers and Nuts.
10. Secure Posts to Chest using fourteen sets of Bolts, Washers and Nuts.
11. Attach two End Caps (8), one to each end of Handle.

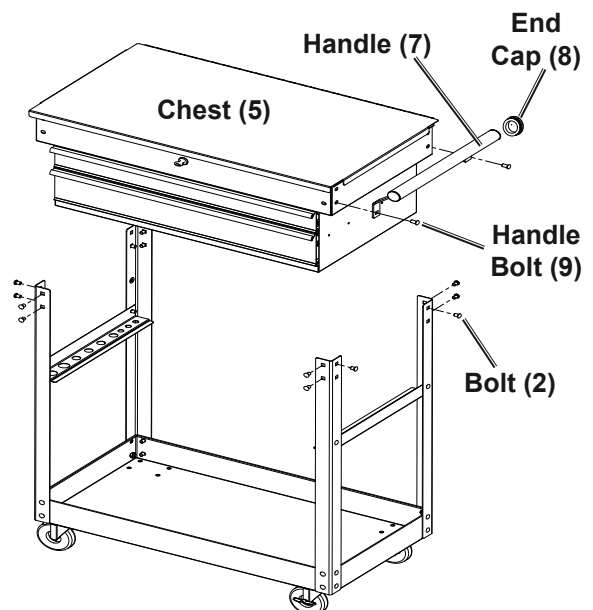

12. Wrench tighten all hardware.

Operation Instructions



Read the **ENTIRE IMPORTANT SAFETY INFORMATION** section at the beginning of this document including all text under subheadings therein before set up or use of this product.

1. Open lid to unlock drawers, then fill Cart evenly, from bottom to top. Do not exceed weight capacities.
2. Close Lid to lock all Drawers, then lock Lid with Key.
3. Unlock Swivel Casters.
4. Roll Cart to a flat, level, hard and smooth surface capable of safely supporting a fully loaded Cart. Do not roll Cart over concrete seams or other rough/uneven surfaces.
5. Lock Swivel Casters.

Maintenance and Servicing



Procedures not specifically explained in this manual must be performed only by a qualified technician.

!WARNING

TO PREVENT SERIOUS INJURY FROM TOOL FAILURE:

Do not use damaged equipment. If any part becomes damaged, have the problem corrected before further use.

1. **PERIODICALLY**, inspect the general condition of the Cart. Check for:
 - loose hardware,
 - misalignment or binding of moving parts,
 - brake operation,
 - caster swivel function and movement,
 - cracked or broken parts,
 - any other condition that may affect its safe operation.
2. Wipe external surfaces of the Cart with clean cloth.
3. Lubricate Drawer Slides as needed.

PLEASE READ THE FOLLOWING CAREFULLY

THE MANUFACTURER AND/OR DISTRIBUTOR HAS PROVIDED THE PARTS LIST AND ASSEMBLY DIAGRAM IN THIS DOCUMENT AS A REFERENCE TOOL ONLY. NEITHER THE MANUFACTURER OR DISTRIBUTOR MAKES ANY REPRESENTATION OR WARRANTY OF ANY KIND TO THE BUYER THAT HE OR SHE IS QUALIFIED TO MAKE ANY REPAIRS TO THE PRODUCT, OR THAT HE OR SHE IS QUALIFIED TO REPLACE ANY PARTS OF THE PRODUCT. IN FACT, THE MANUFACTURER AND/OR DISTRIBUTOR EXPRESSLY STATES THAT ALL REPAIRS AND PARTS REPLACEMENTS SHOULD BE UNDERTAKEN BY CERTIFIED AND LICENSED TECHNICIANS, AND NOT BY THE BUYER. THE BUYER ASSUMES ALL RISK AND LIABILITY ARISING OUT OF HIS OR HER REPAIRS TO THE ORIGINAL PRODUCT OR REPLACEMENT PARTS THERETO, OR ARISING OUT OF HIS OR HER INSTALLATION OF REPLACEMENT PARTS THERETO.

Parts List and Diagram

Parts List

| Part | Description | Qty |
|------|-------------------|-----|
| 1 | Right-handed Post | 2 |
| 2 | Bolt M8 x 12 | 34 |
| 3 | Flat Washer 8 | 52 |
| 4 | Nut M8 | 52 |
| 5 | Chest | 1 |
| 6 | Left-handed Post | 2 |
| 7 | Handle | 1 |
| 8 | End Cap | 2 |

| Part | Description | Qty |
|------|-----------------------|-----|
| 9 | Handle Bolt M8 x 16 | 2 |
| 10 | Cross Support | 2 |
| 11 | Locking Swivel Caster | 2 |
| 12 | Bottom Shelf | 1 |
| 13 | Caster Bolt M8 x 16 | 16 |
| 14 | Fixed Caster | 2 |
| 15 | Key (not shown) | 1 |

Record Serial Number Here: _____

Note: If product has no serial number, record month and year of purchase instead.

Note: Some parts are listed and shown for illustration purposes only, and are not available individually as replacement parts.

Assembly Diagram

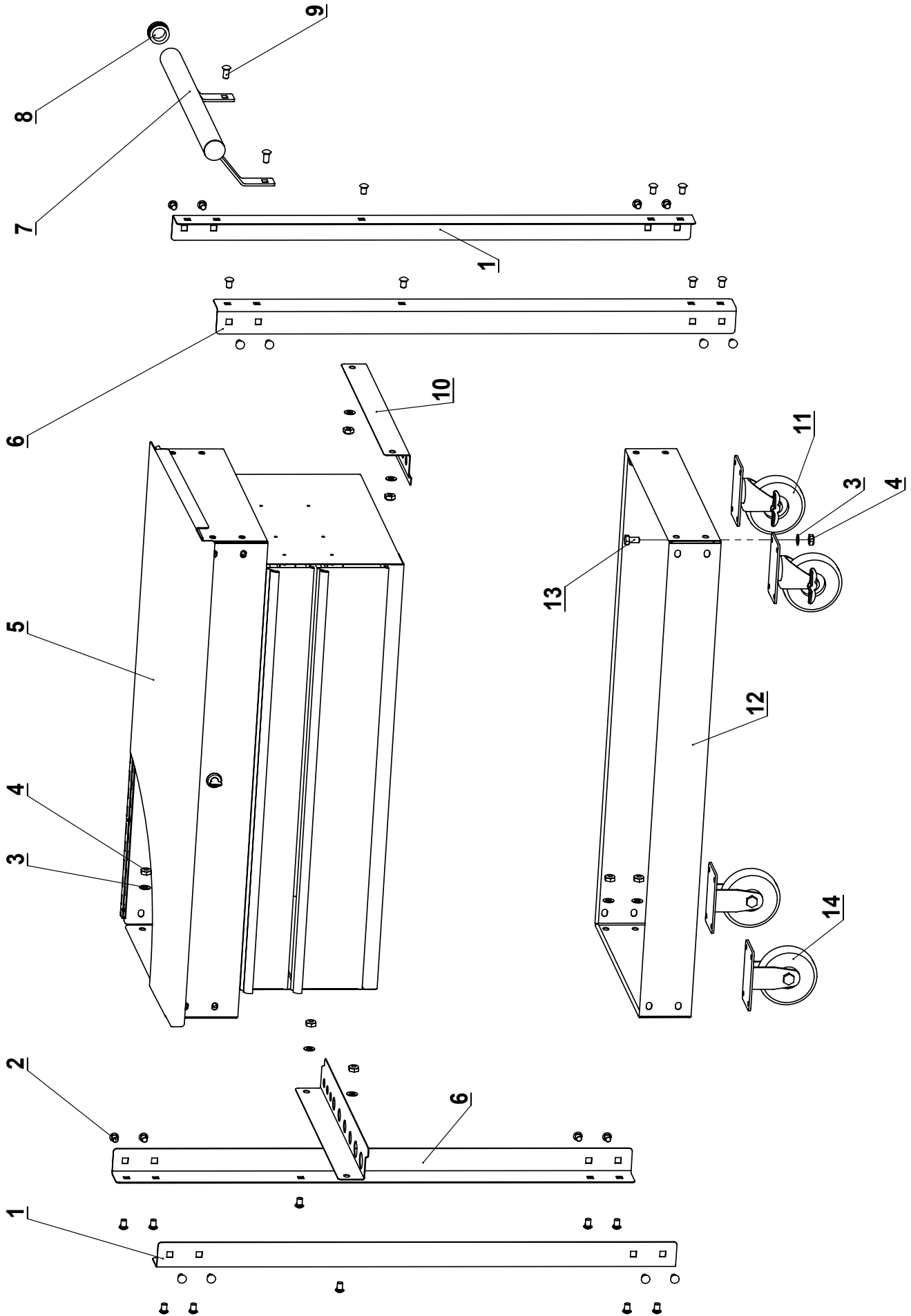

Limited 90 Day Warranty

Harbor Freight Tools Co. makes every effort to assure that its products meet high quality and durability standards, and warrants to the original purchaser that this product is free from defects in materials and workmanship for the period of 90 days from the date of purchase. This warranty does not apply to damage due directly or indirectly, to misuse, abuse, negligence or accidents, repairs or alterations outside our facilities, criminal activity, improper installation, normal wear and tear, or to lack of maintenance. We shall in no event be liable for death, injuries to persons or property, or for incidental, contingent, special or consequential damages arising from the use of our product. Some states do not allow the exclusion or limitation of incidental or consequential damages, so the above limitation of exclusion may not apply to you. THIS WARRANTY IS EXPRESSLY IN LIEU OF ALL OTHER WARRANTIES, EXPRESS OR IMPLIED, INCLUDING THE WARRANTIES OF MERCHANTABILITY AND FITNESS.

To take advantage of this warranty, the product or part must be returned to us with transportation charges prepaid. Proof of purchase date and an explanation of the complaint must accompany the merchandise. If our inspection verifies the defect, we will either repair or replace the product at our election or we may elect to refund the purchase price if we cannot readily and quickly provide you with a replacement. We will return repaired products at our expense, but if we determine there is no defect, or that the defect resulted from causes not within the scope of our warranty, then you must bear the cost of returning the product.

This warranty gives you specific legal rights and you may also have other rights which vary from state to state.



26541 Agoura Road • Calabasas, CA 91302 • 1-888-866-5797