

Owner's Manual & Safety Instructions

Save This Manual Keep this manual for the safety warnings and precautions, assembly, operating, inspection, maintenance and cleaning procedures. Write the product's serial number in the back of the manual near the assembly diagram (or month and year of purchase if product has no number). Keep this manual and the receipt in a safe and dry place for future reference.

201

57338 **1 HP** **Farm Duty**

57339 **2 HP** **Compressor Duty**

57340 **3 HP** **Compressor Duty**

ELECTRIC MOTOR



Item 57339 shown.

Smith+Jones™

Visit our website at: <http://www.harborfreight.com>
Email our technical support at: productsupport@harborfreight.com

When unpacking, make sure that the product is intact and undamaged. If any parts are missing or broken, please call 1-888-866-5797 as soon as possible.

Copyright© 2020 by Harbor Freight Tools®. All rights reserved.
No portion of this manual or any artwork contained herein may be reproduced in any shape or form without the express written consent of Harbor Freight Tools. Diagrams within this manual may not be drawn proportionally. Due to continuing improvements, actual product may differ slightly from the product described herein. Tools required for assembly and service may not be included.

⚠ WARNING

Read this material before using this product. Failure to do so can result in serious injury. **SAVE THIS MANUAL.**

IMPORTANT SAFETY INFORMATION



WARNING Read all safety warnings and instructions.

Failure to heed these markings may result in personal injury and/or property damage.

Save all warnings and instructions for future reference.

The warnings, precautions, and instructions discussed in this manual cannot cover all possible conditions and situations that may occur. The operator must understand that common sense and caution are factors, which cannot be built into this product, but must be supplied by the operator.

1. Study, understand, and follow all instructions before operating this device.
2. To prevent electric shock, connect motor to device according to the instructions detailed in this manual.
3. Be aware of moving parts during use.
4. Do not block motor air vents during use.
5. Verify all mounting hardware is securely fastened before use.
6. Maintain labels and nameplates on the Motor. These carry important information. If unreadable or missing, contact Harbor Freight Tools for a replacement.
7. Wear ANSI-approved safety eye goggles and heavy-duty work gloves when setting up, using or servicing the Motor. Using personal safety devices reduce the risk for injury.
8. Maintain a safe working environment. Keep the work area well lit. Make sure there is adequate surrounding workspace. Keep the work area free of obstructions, grease, oil, trash, and other debris. Do not use or install the motor in areas near flammable chemicals, dusts, and vapors. Do not use this motor in a damp or wet location.
9. Do not overload Motor. This motor will work better and safer at the speed and capacity for which it was designed.
10. Unplug the Motor from its electrical outlet (or turn off the circuit breaker and tag it) before performing any inspection, maintenance, or cleaning procedures.
11. When installing motor, observe all national and local codes. Install, protect, and fuse according to the latest issue of the National Electric Code, NEMA Standard Publication No. MG2, and local codes. Ground frames in accordance with NEC Article 430. For general grounding information, refer to NEC Article 250.
12. Install safety guards when appropriate. Make sure all moving parts, including the shaft and any attached accessories, are permanently guarded to prevent clothing and body parts from being caught.
13. Before each use, check all nuts, bolts, and screws for tightness. Vibration during operation may cause these to loosen.
14. Connect Motor through a properly rated fuse or circuit breaker.
15. Do not allow children or unauthorized personnel to play with, or handle this motor.
16. People with pacemakers should consult their physician(s) before use. Electromagnetic fields in close proximity to heart pacemaker could cause pacemaker interference or pacemaker failure.

Specifications

Item	57338	57339	57340
Type	Farm Duty	Compressor Duty	Compressor Duty
Input	115 / 230VAC, 60Hz, 1 Phase	115 / 230VAC, 60Hz, 1 Phase	230VAC, 60Hz, 1 Phase
HP	1	2	3
RPM	1800	1800	3600
Capacitor	Start	Dual	Dual
Frame	NEMA 56	NEMA 145	NEMA 56

Installation Instructions

1. The ambient air temperature where the motor is to be installed cannot exceed 104° F. If it might, cooling must be provided to ensure the temperature stays below the limit.
2. Install with proper ventilation, making sure to keep away from any moisture.
3. Install indoors in a dry and noncorrosive environment where no flammable liquids or gases are present.
4. When mounting motor, make sure all hardware is securely fastened.
5. When mounting a pulley (not included) to the drive shaft, make sure pulley and shaft are properly aligned or motor life will be significantly shortened.
6. Do not operate motor without installing a safety guard (not supplied), with at least a two inch clearance, around all pulleys and belts driven by motor.
7. Allow for enough room for changing the belt (if attached).

Motor Wire Connections

Figure B: Wiring Diagram indicates the proper wiring connections for each individual motor's internal wires and the external power connections.

"CCW" stands for counterclockwise motor shaft rotation and "CW" stands for clockwise shaft rotation.

Note the markings on the internal wires (i.e., "T3, T4, P1, P2," etc.) and use them as reference for wiring your specific motor.

WARNING! TO PREVENT SERIOUS INJURY: Verify that there is no power to circuit to be connected. Check fuse box and turn off circuit breaker. Also tag breaker switch to prevent accidental shock.

1. Remove Connection Cover to expose the terminal strip. See **Figure A**.
2. Using approved National Electrical Code electrical standards, connect as described in **Figure B**. The facility power circuit, and connecting wires, must be rated to at least 20 amps of current. Use wire lugs (not included) to connect the wires to the Motor terminal strip. The motor can be connected by an appropriate size line cord (not included) or hard wired through conduit.
3. **WARNING! TO PREVENT SERIOUS INJURY:** Connect ground wire to ground screw marked \perp . **Do not leave loose.**
4. Replace motor Connection Cover.

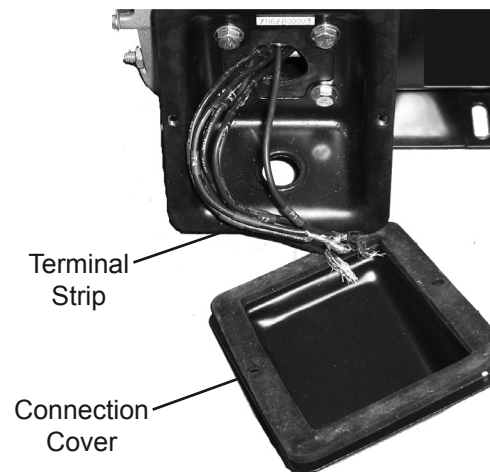

Figure A: Connection Cover Open

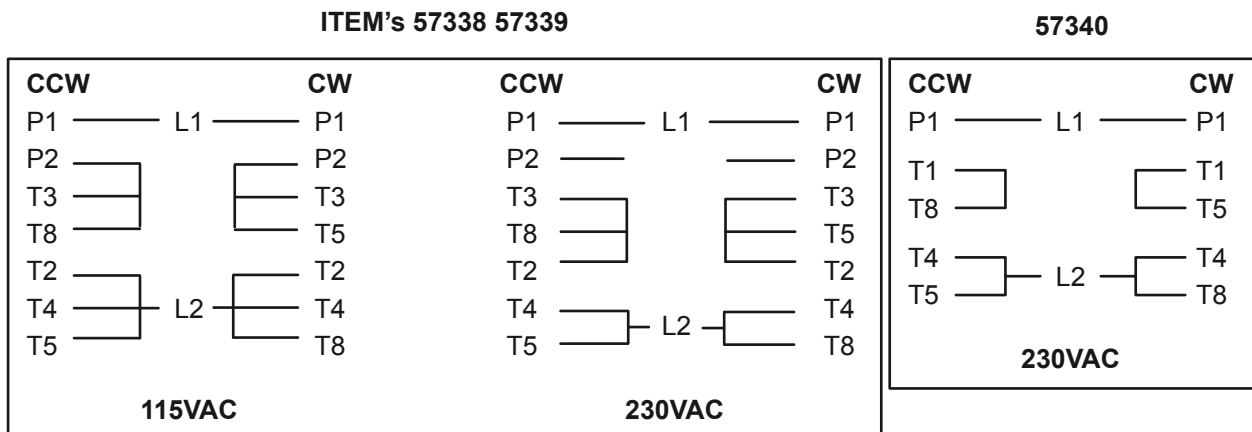

Figure B: Wiring Diagram

Note: All rotation directions are Lead-End (LE), or as viewed from wires at back of motor.

Operation

⚠️WARNING

Before initial operation, verify that motor is dry and all connections to the motor are correct.

1. Verify the rotor turns freely when disconnected from the load.
2. Also verify the motor is detached from the load for the initial start.
3. Check that the voltage is correct and balanced at the motor terminals and that the no-load current draw is correct.

Note: If motor suddenly stops, check that its rotation is not limited or blocked, then press the reset button on the switch box. If the problem persists, check voltage supply and contact a qualified technician.

Note: Replacement parts are not available for this item. Reference UPC:

1 HP: 792363573382

2 HP: 792363573399

3 HP: 792363573405

NOTE: Make sure motor is not being overloaded once it comes to its operational speed (see Specifications chart for each motor's specific RPM).

Inspection, Maintenance, and Cleaning



Procedures not specifically explained in this manual must be performed only by a qualified technician.

⚠️WARNING

TO PREVENT SERIOUS INJURY FROM ACCIDENTAL OPERATION: Make sure the Motor circuit breaker is off before performing any inspection, maintenance, or cleaning procedures.

1. Before each use, inspect the general condition of the Motor. Check for loose screws, misalignment or binding of moving parts, cracked or broken parts, damaged electrical wiring, and any other condition that may affect its safe operation. If abnormal noise or vibration occurs, have the problem corrected before further use. Do not use damaged equipment.
2. Periodically recheck all nuts, bolts, and screws for tightness.

Lubrication

1. Re-oil sleeve bearings with drops of 5W20 viscosity motor oil every 2000 hours of normal service. Direct drive operation (no pulleys) requires lubrication every 3000 hours of normal service.
2. Sealed ball bearings require no attention during the life of the bearing.

Limited 90 Day Warranty

Harbor Freight Tools Co. makes every effort to assure that its products meet high quality and durability standards, and warrants to the original purchaser that this product is free from defects in materials and workmanship for the period of 90 days from the date of purchase. This warranty does not apply to damage due directly or indirectly, to misuse, abuse, negligence or accidents, repairs or alterations outside our facilities, criminal activity, improper installation, normal wear and tear, or to lack of maintenance. We shall in no event be liable for death, injuries to persons or property, or for incidental, contingent, special or consequential damages arising from the use of our product. Some states do not allow the exclusion or limitation of incidental or consequential damages, so the above limitation of exclusion may not apply to you. THIS WARRANTY IS EXPRESSLY IN LIEU OF ALL OTHER WARRANTIES, EXPRESS OR IMPLIED, INCLUDING THE WARRANTIES OF MERCHANTABILITY AND FITNESS.

To take advantage of this warranty, the product or part must be returned to us with transportation charges prepaid. Proof of purchase date and an explanation of the complaint must accompany the merchandise. If our inspection verifies the defect, we will either repair or replace the product at our election or we may elect to refund the purchase price if we cannot readily and quickly provide you with a replacement. We will return repaired products at our expense, but if we determine there is no defect, or that the defect resulted from causes not within the scope of our warranty, then you must bear the cost of returning the product.

This warranty gives you specific legal rights and you may also have other rights which vary from state to state.

Smith+Jones™

26541 Agoura Road Calabasas, CA 91302 • 1-888-866-5797