

Owner's Manual & Safety Instructions

Save This Manual Keep this manual for the safety warnings and precautions, assembly, operating, inspection, maintenance and cleaning procedures. Write the product's serial number in the back of the manual near the assembly diagram (or month and year of purchase if product has no number). Keep this manual and the receipt in a safe and dry place for future reference.

21a

WARRIOR™

9-PIECE CARBIDE GRIT HOLE SAW SET



Visit our website at: <http://www.harborfreight.com>
Email our technical support at: productsupport@harborfreight.com

57708

When unpacking, make sure that the product is intact and undamaged. If any parts are missing or broken, please call 1-888-866-5797 as soon as possible.

Copyright© 2020 by Harbor Freight Tools®. All rights reserved.
No portion of this manual or any artwork contained herein may be reproduced in any shape or form without the express written consent of Harbor Freight Tools. Diagrams within this manual may not be drawn proportionally. Due to continuing improvements, actual product may differ slightly from the product described herein. Tools required for assembly and service may not be included.

⚠WARNING

Read this material before using this product.
Failure to do so can result in serious injury.
SAVE THIS MANUAL.

SPECIFICATIONS

Type	Carbide Grit
Piece Count	9
Saw Sizes	1-1/4", 2-1/8", 2-5/8", 2-7/8", 3-1/4"
Other Pieces	Carbide Grit File Backing Plate Pilot Bit Blow Molded Case

IMPORTANT SAFETY INFORMATION

The warnings, cautions, and instructions discussed in this instruction manual cannot cover all possible conditions and situations that may occur. It must be understood by the operator that common sense and caution are factors which cannot be built into this product, but must be supplied by the operator.

1. **Wear ANSI-approved safety goggles and heavy-duty work gloves during setup and use.**
2. **Keep away from children.**
3. **Verify drill's chuck is in good condition and fits securely.**
4. **Do not use excessive pressure when cutting a hole.**
5. **Use as intended only; do not modify tools.**
6. **Inspect before every use; do not use if parts are loose or damaged.**
7. **Use both hands when drilling and keep saw at 90° to workpiece.**
8. **Store saws in Case in secure location away from children.**
9. **Do not exceed 1500 RPM.**
10. **Read and adhere to all safety warnings and operating instructions of drill used with Set.**

 **SAVE THESE INSTRUCTIONS.**

WARRIOR™

SETUP

⚠ CAUTION

TO PREVENT INJURY:

Wear heavy-duty work gloves and ANSI-approved safety goggles during setup and whenever handling the Hole Saws.

1. Find the circular slot in the Backing Plate that corresponds to the Hole Saw.
2. Align the three slots in the Hole Saw with the three rails on the Backing Plate, and press the Hole Saw evenly against the Backing Plate, see **step A** in illustration.

Note: The Hole Saw will not attach properly unless it seats evenly against the Backing Plate.

3. After the Hole Saw is seated against the Backing Plate, turn it clockwise (viewed from grit side of Saw) firmly to lock it in place, see **step B** in illustration.
4. Turn the Pilot Bit so that the flat on its shank faces the same direction as the Bolt on the side of the Backing Plate.
5. Insert the Pilot Bit into the center of the Backing Plate so that the spade tip extends through the middle of the Hole Saw, see **step C** in illustration.

Note: The Pilot Bit is properly positioned when its shank extends through the middle of the Backing Plate 1-1/4" – 1-3/8".

6. Tighten the Bolt on the side of the Backing Plate to fasten the Pilot Bit, see **step D** in illustration.
7. Open Drill's Chuck (sold separately).
8. Place the Pilot Bit's Shank completely into the Chuck and securely tighten the Chuck.

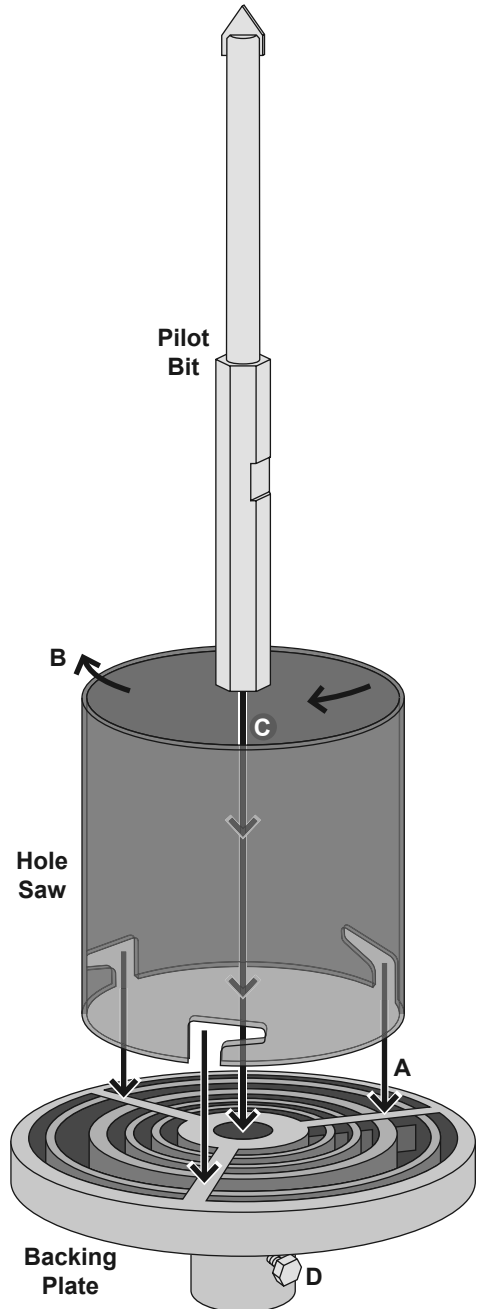

OPERATION

1. If possible, place the workpiece on a piece of scrap wood to support it while cutting.
2. Holding the drill at 90° to the workpiece, press the pilot bit tip firmly against the workpiece where the center is marked.
3. Press the drill's trigger to turn it on.
4. If the drill is a variable speed type, cut the workpiece slowly until a circle groove is made in the workpiece. Then cut faster.
5. When the hole is cut, release the trigger and wait for Hole Saw to come to a complete stop before removing it from the workpiece.
6. File can be used to refine or smooth hole.
7. When finished, remove Hole Saw from drill's chuck.
8. Remove Hole Saw and Pilot Bit from Backing Plate.
9. Store inside case, out of reach of children.

Note: Replacement parts are not available for this item. Reference UPC 193175421401.

LIMITED 90 DAY WARRANTY

Harbor Freight Tools Co. makes every effort to assure that its products meet high quality and durability standards, and warrants to the original purchaser that this product is free from defects in materials and workmanship for the period of 90 days from the date of purchase. This warranty does not apply to damage due directly or indirectly, to misuse, abuse, negligence or accidents, repairs or alterations outside our facilities, criminal activity, improper installation, normal wear and tear, or to lack of maintenance. We shall in no event be liable for death, injuries to persons or property, or for incidental, contingent, special or consequential damages arising from the use of our product. Some states do not allow the exclusion or limitation of incidental or consequential damages, so the above limitation of exclusion may not apply to you. THIS WARRANTY IS EXPRESSLY IN LIEU OF ALL OTHER WARRANTIES, EXPRESS OR IMPLIED, INCLUDING THE WARRANTIES OF MERCHANTABILITY AND FITNESS.

To take advantage of this warranty, the product or part must be returned to us with transportation charges prepaid. Proof of purchase date and an explanation of the complaint must accompany the merchandise. If our inspection verifies the defect, we will either repair or replace the product at our election or we may elect to refund the purchase price if we cannot readily and quickly provide you with a replacement. We will return repaired products at our expense, but if we determine there is no defect, or that the defect resulted from causes not within the scope of our warranty, then you must bear the cost of returning the product.

This warranty gives you specific legal rights and you may also have other rights which vary from state to state.

