

Owner's Manual & Safety Instructions

Save This Manual Keep this manual for the safety warnings and precautions, assembly, operating, inspection, maintenance and cleaning procedures. Write the product's serial number in the back of the manual near the assembly diagram (or month and year of purchase if product has no number). Keep this manual and the receipt in a safe and dry place for future reference.

21k

HAULMASTER

2000 LB. CAPACITY A-FRAME TRAILER JACK



Visit our website at: <http://www.harborfreight.com>
Email our technical support at: productsupport@harborfreight.com

57734

When unpacking, make sure that the product is intact and undamaged. If any parts are missing or broken, please call 1-888-866-5797 as soon as possible.

Copyright© 2021 by Harbor Freight Tools®. All rights reserved.

No portion of this manual or any artwork contained herein may be reproduced in any shape or form without the express written consent of Harbor Freight Tools. Diagrams within this manual may not be drawn proportionally. Due to continuing improvements, actual product may differ slightly from the product described herein. Tools required for assembly and service may not be included.

⚠WARNING

Read this material before using this product. Failure to do so can result in serious injury. **SAVE THIS MANUAL.**

Table of Contents





Safety	2	Maintenance	7
Specifications	4	Parts List and Assembly Diagram.....	7
Installation	5	Warranty	8
Operation.....	6		

SAFETY

INSTALLATION

OPERATION

MAINTENANCE

WARNING SYMBOLS AND DEFINITIONS	
	This is the safety alert symbol. It is used to alert you to potential personal injury hazards. Obey all safety messages that follow this symbol to avoid possible injury or death.
	Indicates a hazardous situation which, if not avoided, will result in death or serious injury.
	Indicates a hazardous situation which, if not avoided, could result in death or serious injury.
	Indicates a hazardous situation which, if not avoided, could result in minor or moderate injury.
	Addresses practices not related to personal injury.

IMPORTANT SAFETY INFORMATION

WARNING

Read all safety warnings and instructions.
Failure to follow the warnings and instructions may result in serious injury.
Save all warnings and instructions for future reference.

Basic Safety Information

Keep work area clean and well lit.
Cluttered or dark areas invite accidents.

Personal Safety

- Stay alert, watch what you are doing and use common sense when operating a tool. Do not use a tool while you are tired or under the influence of drugs, alcohol or medication.**
A moment of inattention while operating tools may result in serious personal injury.
- Use personal protective equipment. Always wear eye protection.** *Safety equipment such as non-skid safety shoes or a hard hat used for appropriate conditions will reduce personal injuries.*

Service

Have your tool serviced by a qualified repair person using only identical replacement parts. *This will ensure that the safety of the tool is maintained.*

Specific Safety Warnings

1. Do not exceed rated capacity.
2. Install on A-frame coupler before use.
3. Use on flat, level, hard surface capable of supporting load.
4. Wear ANSI-approved safety goggles during use.
5. Prevent trailer wheels from moving using wheel chocks while raising or lowering.
6. Before towing, fully raise Trailer Jack. Jack must always be retracted when towing the trailer.
7. Keep out from under Jack and tongue when applying and releasing load, when Jack is supporting load, or when moving trailer.
8. Inspect before use. Do not use if parts are loose or damaged.
9. Use in accord with DOT regulations.
10. Maintain labels and nameplates on the tool. These carry important safety information. If unreadable or missing, contact Harbor Freight Tools for a replacement.
11. Apply force to Jack vertically only. Side forces will compromise the Jack.
12. Do not use blocks for additional ground clearance.
13. Do not climb aboard any vehicle supported by Jack.
14. This product is not a toy. Keep it out of reach of children.
15. Follow all state regulations for towing when using Trailer Jack, including using safety chains securely attached to the towing vehicle when the trailer is hooked to the vehicle.
16. Check ground clearance carefully after installing. If your trailer does not provide enough ground clearance for the Jack, remove the Jack entirely before towing trailer.
17. Do not use for aircraft purposes.
18. The warnings, precautions, and instructions discussed in this instruction manual cannot cover all possible conditions and situations that may occur. It must be understood by the operator that common sense and caution are factors which cannot be built into this product, but must be supplied by the operator.



SAVE THESE INSTRUCTIONS.

Functional Description

Specifications

Weight Capacity	2000 lb.
Travel Length	15"
Lift Range	8"– 23"
Application	For use with A-frame coupler trailers
Hardware (sold separately)	3 bolts 3/8" D x 1" L (grade 8 or better), 3 lock washers, 3 flat washers

Components

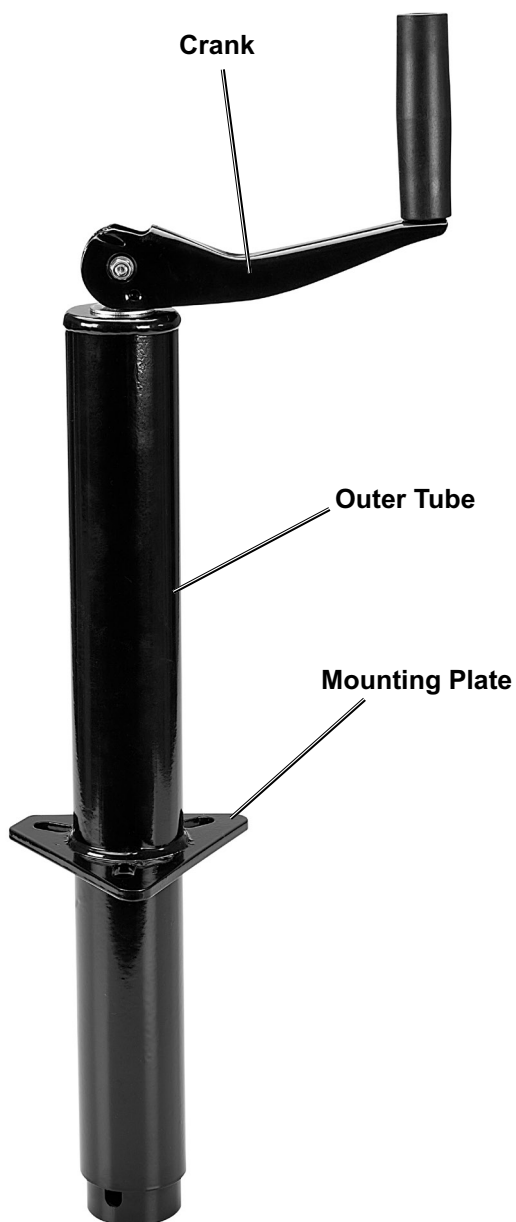

SAFETY

INSTALLATION

OPERATION

MAINTENANCE

Installation Instructions



Read the **ENTIRE IMPORTANT SAFETY INFORMATION** section at the beginning of this manual including all text under subheadings therein before set up or use of this product.

Note: For additional information regarding the parts listed in the following pages, refer to *Parts List and Diagram* on page 7.

Mounting

This Trailer Jack is designed **specifically for use with an A-frame coupler**. Never attempt to mount this Trailer Jack to a coupler or trailer not specifically designed for it. An example of an A-frame coupler is shown in Figure A. Check that the Outer Tube (5) of the Jack will fit into the A-frame opening and that the Mounting Plate holes align with the bolt locations on the trailer. Only a qualified technician should modify the trailer if needed.

1. Block the wheels and support the trailer tongue securely using jack stands (sold separately).
2. Insert the bottom of the Trailer Jack through the hole in the center of the A-frame coupler from above. Line up the holes on the Mounting Plate with the bolt holes in the A-frame coupler.
3. Secure the jack mounting plate to the A-frame coupler using grade 8 bolts, lock washers, and flat washers (all sold separately). Slide a lock washer then a flat washer onto each bolt, then insert the bolt through the jack mounting plate, and screw the bolt into the threaded hole in the A-frame coupler. Tighten the mounting hardware firmly to 30 ft-lbs. utilizing a torque wrench (sold separately).
4. A foot plate (sold separately) may be installed on the bottom of the Trailer Jack.

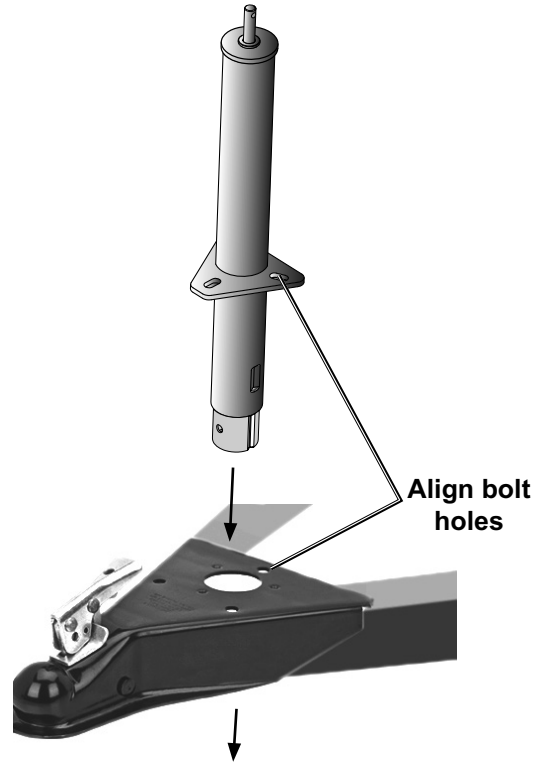

Figure A: Inserting Trailer Jack into Coupler

5. Once the Jack is mounted to the trailer tongue, attach the Crank (2) to the Jack Screw (8) at the top of the Trailer Jack. Secure Crank in place with the Bolt (3) and Lock Nut (1). Securely tighten all hardware.

HAULMASTER™

Operation Instructions



Read the **ENTIRE IMPORTANT SAFETY INFORMATION** section at the beginning of this manual including all text under subheadings therein before set up or use of this product.

Mounting the Trailer to the Towing Vehicle

1. Before mounting, chock the trailer wheels to prevent the trailer from rolling.
2. Pull the Crank (2) out so that the knob is on top. Rotate the Crank clockwise to extend the Jack and raise the trailer hitch above the level of the towing vehicle's hitch ball. Once the trailer is at the desired height, fold the Crank over so that the knob is facing downward. This will help keep the knob out of the way.
3. With the assistance of a spotter, back the vehicle to the trailer.
4. Align the hitch ball directly under the trailer hitch.
5. Turn the Crank counterclockwise to retract the Jack slightly, lowering the trailer and transferring its weight onto the towing vehicle until it is firmly seated on the hitch ball. Tighten the trailer hitching mechanism.
6. Once trailer is fully engaged, continue to retract Jack to its uppermost position. Retract the Trailer Jack fully before towing the trailer. Flip the Crank up and over when completed to help keep the knob out of the way.
7. Attach the safety chain (sold separately).

Dismounting the Trailer from the Towing Vehicle

1. Before dismounting, chock the trailer wheels to prevent the trailer from rolling.
 2. Pull the Crank out so that the knob is on top. Rotate the Crank clockwise to extend the Jack and raise the trailer.
 3. Continue to extend just enough for the Trailer Jack to take the weight of the trailer. This will make it easier to disengage the trailer hitch.
 4. Disengage the trailer hitch and any safety chains or other connections between the vehicle and the trailer.
 5. It may be necessary to extend the Jack further to clear the trailer hitch. When the vehicle is completely clear, and it is safe to do so, drive the vehicle away from the trailer.
- CAUTION:** Have a spotter watch this operation to be sure the trailer is clear of the vehicle.
6. Level the trailer by turning the Crank to raise or lower the trailer to the desired height. Flip the Crank up and over when completed to help keep the knob out of the way.

PLEASE READ THE FOLLOWING CAREFULLY

THE MANUFACTURER AND/OR DISTRIBUTOR HAS PROVIDED THE PARTS LIST AND ASSEMBLY DIAGRAM IN THIS MANUAL AS A REFERENCE TOOL ONLY. NEITHER THE MANUFACTURER OR DISTRIBUTOR MAKES ANY REPRESENTATION OR WARRANTY OF ANY KIND TO THE BUYER THAT HE OR SHE IS QUALIFIED TO MAKE ANY REPAIRS TO THE PRODUCT, OR THAT HE OR SHE IS QUALIFIED TO REPLACE ANY PARTS OF THE PRODUCT. IN FACT, THE MANUFACTURER AND/OR DISTRIBUTOR EXPRESSLY STATES THAT ALL REPAIRS AND PARTS REPLACEMENTS SHOULD BE UNDERTAKEN BY CERTIFIED AND LICENSED TECHNICIANS, AND NOT BY THE BUYER. THE BUYER ASSUMES ALL RISK AND LIABILITY ARISING OUT OF HIS OR HER REPAIRS TO THE ORIGINAL PRODUCT OR REPLACEMENT PARTS THERETO, OR ARISING OUT OF HIS OR HER INSTALLATION OF REPLACEMENT PARTS THERETO.

User-Maintenance Instructions



Procedures not specifically explained in this manual must be performed only by a qualified technician.

WARNING

TO PREVENT SERIOUS INJURY:

Remove Jack from trailer before performing any inspection, maintenance, or cleaning procedures.

TO PREVENT SERIOUS INJURY FROM TOOL FAILURE:

Do not use damaged equipment. If abnormal noise or vibration occurs, have the problem corrected before further use.

Cleaning, Maintenance, and Lubrication

- BEFORE EACH USE**, inspect the general condition of the tool. Check for:
 - loose hardware
 - misalignment or binding of moving parts
 - cracked or broken parts
 - any other condition that may affect its safe operation
- If welded, check welds for cracks.
- If the Trailer Jack has been exposed to salt water, immediately wash off with fresh water. Then use a light oil to lubricate all moving parts.
- AFTER USE**, wipe external surfaces of the tool with clean cloth.

Parts List and Diagram

Part	Description	Qty
1	Lock Nut, M6	1
2	Crank	1
3	Bolt, M6x38	1
4	Washer	1
5	Outer Tube	1
6	Bearing	1
7	Washer	1
8	Thread	1
9	Nut	1
10	Inner Tube	1

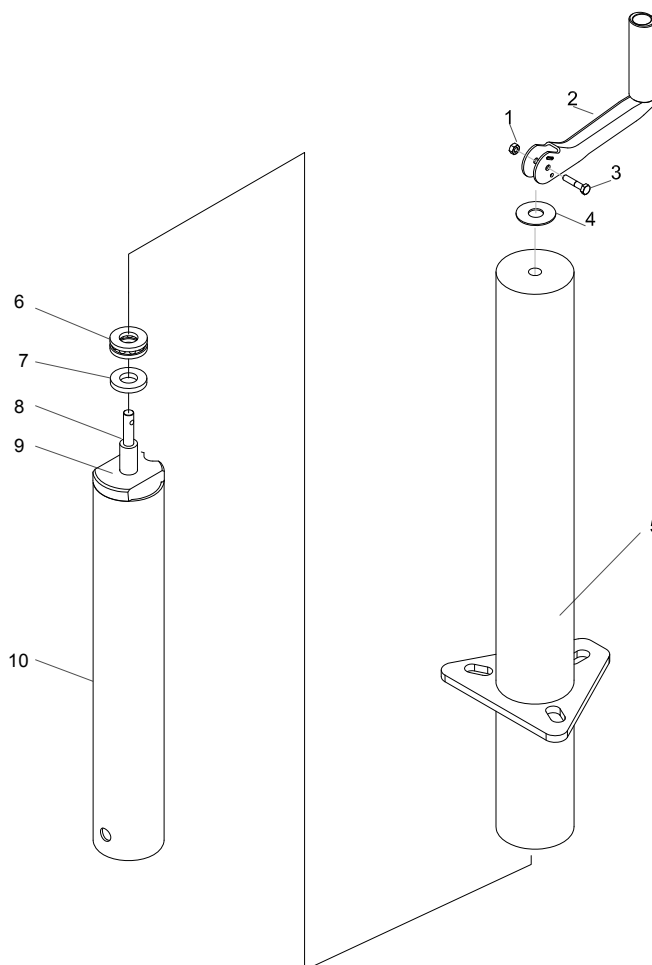

Record Product's Serial Number Here:

Note: If product has no serial number, record month and year of purchase instead.

Note: Some parts are listed and shown for illustration purposes only, and are not available individually as replacement parts. Specify UPC 193175447678 when ordering parts.

Limited 90 Day Warranty

Harbor Freight Tools Co. makes every effort to assure that its products meet high quality and durability standards, and warrants to the original purchaser that this product is free from defects in materials and workmanship for the period of 90 days from the date of purchase. This warranty does not apply to damage due directly or indirectly, to misuse, abuse, negligence or accidents, repairs or alterations outside our facilities, criminal activity, improper installation, normal wear and tear, or to lack of maintenance. We shall in no event be liable for death, injuries to persons or property, or for incidental, contingent, special or consequential damages arising from the use of our product. Some states do not allow the exclusion or limitation of incidental or consequential damages, so the above limitation of exclusion may not apply to you. THIS WARRANTY IS EXPRESSLY IN LIEU OF ALL OTHER WARRANTIES, EXPRESS OR IMPLIED, INCLUDING THE WARRANTIES OF MERCHANTABILITY AND FITNESS.

To take advantage of this warranty, the product or part must be returned to us with transportation charges prepaid. Proof of purchase date and an explanation of the complaint must accompany the merchandise. If our inspection verifies the defect, we will either repair or replace the product at our election or we may elect to refund the purchase price if we cannot readily and quickly provide you with a replacement. We will return repaired products at our expense, but if we determine there is no defect, or that the defect resulted from causes not within the scope of our warranty, then you must bear the cost of returning the product.

This warranty gives you specific legal rights and you may also have other rights which vary from state to state.

HAULMASTER[™]

26677 Agoura Road • Calabasas, CA 91302 • 1-888-866-5797