

# Owner's Manual & Safety Instructions

**Save This Manual** Keep this manual for the safety warnings and precautions, assembly, operating, inspection, maintenance and cleaning procedures. Write the product's serial number in the back of the manual near the assembly diagram (or month and year of purchase if product has no number). Keep this manual and the receipt in a safe and dry place for future reference.

21i

# CENTRAL<sup>®</sup> MACHINERY

## 20" HIGH VELOCITY FLOOR FAN



57880

Visit our website at: <http://www.harborfreight.com>  
Email our technical support at: [productsupport@harborfreight.com](mailto:productsupport@harborfreight.com)

When unpacking, make sure that the product is intact and undamaged. If any parts are missing or broken, please call 1-888-866-5797 as soon as possible.

Copyright© 2020 by Harbor Freight Tools®. All rights reserved.

No portion of this manual or any artwork contained herein may be reproduced in any shape or form without the express written consent of Harbor Freight Tools. Diagrams within this manual may not be drawn proportionally. Due to continuing improvements, actual product may differ slightly from the product described herein. Tools required for assembly and service may not be included.

### **⚠ WARNING**

Read this material before using this product. Failure to do so can result in serious injury. **SAVE THIS MANUAL.**



# READ AND SAVE THESE INSTRUCTIONS.

## RULES FOR SAFE OPERATION

1. **WARNING!** To reduce the risk of fire or electric shock, do not use this Fan with any solid-state speed control device.
2. Do not leave Fan running while unattended.
3. Do not operate any fan with a damaged cord or plug. Discard fan or return to an authorized service facility for examination and/or repair.
4. Do not run cord under carpeting. Do not cover cord with throw rugs, runners, or similar coverings. Do not route cord under furniture or appliances. Arrange cord away from traffic area and where it will not be tripped over.
5. Never insert fingers, pencils, or any other object through Front or Rear Blade Guards.
6. Disconnect Fan when moving it from one location to another.
7. Disconnect Fan before removing grills for cleaning.
8. Be sure fan is on a stable surface when operating to avoid overturning.
9. DO NOT use fan in window. Rain may create electrical hazard.
10. Complete the assembly of the fan before switching on the fan.
11. Maintain labels and nameplates on the fan. If unreadable or missing, contact Harbor Freight Tools for a replacement.
12. Use only in dry areas. Do not use in bathrooms, laundry area, near sinks or other sources of water.
13. This fan is not a toy. Keep it out of reach of children.
14. People with pacemakers should consult their physician(s) before use. Electromagnetic fields in close proximity to heart pacemaker could cause pacemaker interference or pacemaker failure.
15. The warnings, precautions, and instructions discussed in this instruction manual cannot cover all conditions and situations that may occur. It must be understood by operator that common sense and caution are factors which cannot be built into this fan, but must be supplied by operator.

### WARNING SYMBOLS AND DEFINITIONS

|  |  |
|--|--|
|  | This is the safety alert symbol. It is used to alert you to potential personal injury hazards. Obey all safety messages that follow this symbol to avoid possible injury or death. |
|  | Indicates a hazardous situation which, if not avoided, will result in death or serious injury.   |
|  | Indicates a hazardous situation which, if not avoided, could result in death or serious injury.  |
|  | Indicates a hazardous situation which, if not avoided, could result in minor or moderate injury.   |
|  | Addresses practices not related to personal injury.  |

# CENTRAL<sup>®</sup>

## MACHINERY

## Specifications

|                   |  |
|-------------------|--|
| Electrical Rating | 120VAC / 60Hz / 1.38A                          |
| Speed             | Low 1017 RPM / Medium 1156 RPM / High 1330 RPM |

## HOUSEHOLD USE ONLY

## Assembly and Operation



Read the **ENTIRE** RULES FOR SAFE OPERATION section at the beginning of this manual including all text under subheadings therein before set up or use of this fan.

1. Insert the fan onto the bracket until the buttons snap into place.

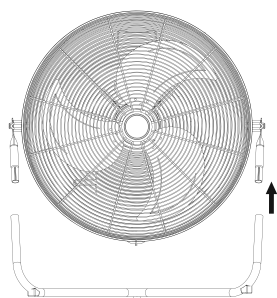

4. The fan may be tilted as desired.

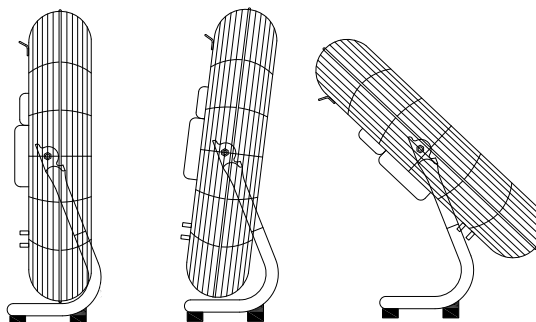

2. Plug fan into 120VAC, 60Hz outlet.
3. Turn fan on by rotating the switch on the back: 0 is Off, 1 is Low, 2 is Medium, and 3 is High.

5. To prevent accidents, turn off the fan and unplug it after use. Clean, then store the fan indoors out of children's reach.

## User Servicing Instructions



Procedures not specifically explained in this manual must be performed only by a qualified technician.

### **WARNING**

**TO PREVENT SERIOUS INJURY FROM ACCIDENTAL OPERATION OR ELECTRIC SHOCK:** Turn the Power Switch of the fan off, unplug the fan from its electrical outlet, and allow the fan to cool completely before performing any inspection, maintenance, or cleaning procedures.

**TO PREVENT SERIOUS INJURY FROM FAN FAILURE:** Do not use damaged equipment. If abnormal noise or vibration occurs, have the problem corrected before further use.

1. **BEFORE EACH USE**, inspect the general condition of the fan. Check for:
  - loose hardware,
  - misalignment or binding of moving parts,
  - cracked or broken parts,
  - damaged electrical wiring, and
  - any other condition that may affect its safe operation.
2. Clean regularly to prevent dust from accumulating on Blade. Use damp cloth during cleaning and dry before use.
3. **WARNING! TO PREVENT SERIOUS INJURY: If the supply cord of this fan is damaged, it must be replaced only by a qualified service technician.**

Record Serial Number Here: \_\_\_\_\_

**Note:** If fan has no serial number, record month and year of purchase instead.

**Note:** Replacement parts are not available for this item. Reference UPC 193175424686.

## Limited 90 Day Warranty

Harbor Freight Tools Co. makes every effort to assure that its products meet high quality and durability standards, and warrants to the original purchaser that this product is free from defects in materials and workmanship for the period of 90 days from the date of purchase. This warranty does not apply to damage due directly or indirectly, to misuse, abuse, negligence or accidents, repairs or alterations outside our facilities, criminal activity, improper installation, normal wear and tear, or to lack of maintenance. We shall in no event be liable for death, injuries to persons or property, or for incidental, contingent, special or consequential damages arising from the use of our product. Some states do not allow the exclusion or limitation of incidental or consequential damages, so the above limitation of exclusion may not apply to you. THIS WARRANTY IS EXPRESSLY IN LIEU OF ALL OTHER WARRANTIES, EXPRESS OR IMPLIED, INCLUDING THE WARRANTIES OF MERCHANTABILITY AND FITNESS.

To take advantage of this warranty, the product or part must be returned to us with transportation charges prepaid. Proof of purchase date and an explanation of the complaint must accompany the merchandise. If our inspection verifies the defect, we will either repair or replace the product at our election or we may elect to refund the purchase price if we cannot readily and quickly provide you with a replacement. We will return repaired products at our expense, but if we determine there is no defect, or that the defect resulted from causes not within the scope of our warranty, then you must bear the cost of returning the product.

This warranty gives you specific legal rights and you may also have other rights which vary from state to state.

**CENTRAL<sup>®</sup>**  
**MACHINERY**

26541 Agoura Road • Calabasas, CA 91302 • 1-888-866-5797