

Owner's Manual & Safety Instructions

Save This Manual Keep this manual for the safety warnings and precautions, assembly, operating, inspection, maintenance and cleaning procedures. Write the product's serial number in the back of the manual near the assembly diagram (or month and year of purchase if product has no number). Keep this manual and the receipt in a safe and dry place for future reference.

211

Bauer™

2174C-BS

BRUSHLESS

20V

HYPERMAX™ LITHIUM

For Longer Run Time Use
3.0 Amp Hour Battery Or
Greater (Sold Separately)

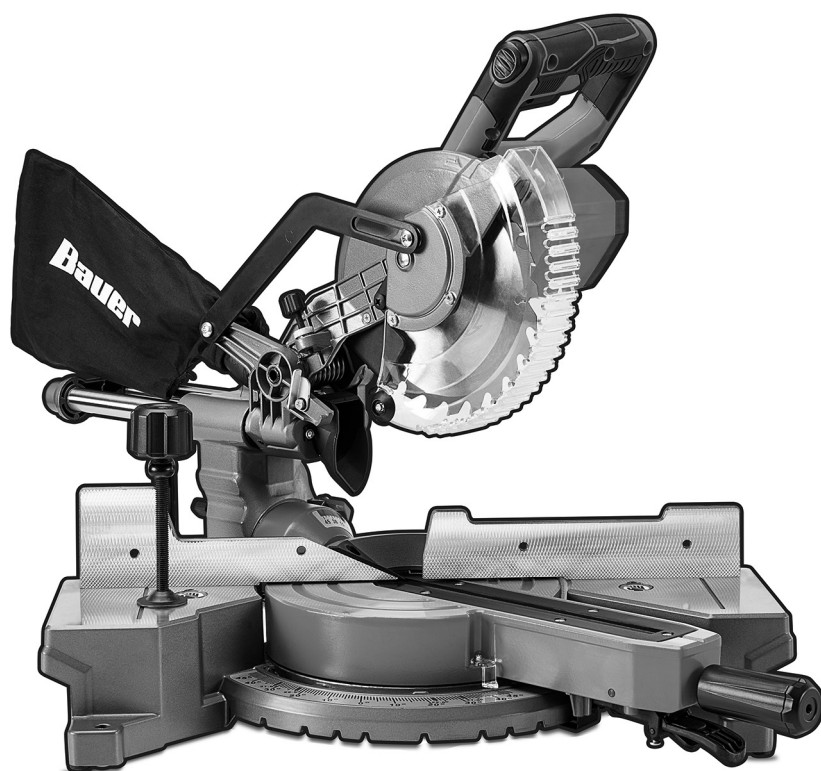

7-1/4" SLIDING MITER SAW

Visit our website at: <http://www.harborfreight.com>
Email our technical support at: productsupport@harborfreight.com

57921

When unpacking, make sure that the product is intact and undamaged. If any parts are missing or broken, please call 1-888-866-5797 as soon as possible.

Copyright© 2021 by Harbor Freight Tools®. All rights reserved.
No portion of this manual or any artwork contained herein may be reproduced in any shape or form without the express written consent of Harbor Freight Tools. Diagrams within this manual may not be drawn proportionally. Due to continuing improvements, actual product may differ slightly from the product described herein. Tools required for assembly and service may not be included.

⚠ WARNING

Read this material before using this product.
Failure to do so can result in serious injury.
SAVE THIS MANUAL.

Table of Contents

Safety	2	Maintenance	15
Specifications	8	Parts List and Diagram	18
Setup	8	Warranty	20
Operation	11		

SAFETY



SETUP

OPERATION

MAINTENANCE

WARNING SYMBOLS AND DEFINITIONS	
	This is the safety alert symbol. It is used to alert you to potential personal injury hazards. Obey all safety messages that follow this symbol to avoid possible injury or death.
	Indicates a hazardous situation which, if not avoided, will result in death or serious injury.
	Indicates a hazardous situation which, if not avoided, could result in death or serious injury.
	Indicates a hazardous situation which, if not avoided, could result in minor or moderate injury.
	Addresses practices not related to personal injury.

IMPORTANT SAFETY INFORMATION

General Power Tool Safety Warnings

WARNING

Read all safety warnings, instructions, illustrations and specifications provided with this power tool. Failure to follow all instructions listed below may result in electric shock, fire and/or serious injury.

Save all warnings and instructions for future reference.

The term "power tool" in the warnings refers to your mains-operated (corded) power tool or battery-operated (cordless) power tool.

1. **Work area safety**
 - a. **Keep work area clean and well lit.**
Cluttered or dark areas invite accidents.
 - b. **Do not operate power tools in explosive atmospheres, such as in the presence of flammable liquids, gases or dust.** *Power tools create sparks which may ignite the dust or fumes.*
 - c. **Keep children and bystanders away while operating a power tool.** *Distractions can cause you to lose control.*

2. Electrical safety

- a. **Avoid body contact with earthed or grounded surfaces, such as pipes, radiators, ranges and refrigerators.**
There is an increased risk of electric shock if your body is earthed or grounded.
- b. **Do not expose power tools to rain or wet conditions.** *Water entering a power tool will increase the risk of electric shock.*

3. Personal safety

- a. **Stay alert, watch what you are doing and use common sense when operating a power tool. Do not use a power tool while you are tired or under the influence of drugs, alcohol or medication.** *A moment of inattention while operating power tools may result in serious personal injury.*
- b. **Use personal protective equipment. Always wear eye protection.** *Protective equipment such as dust mask, non-skid safety shoes, hard hat, or hearing protection used for appropriate conditions will reduce personal injuries.*
- c. **Prevent unintentional starting. Ensure the switch is in the off-position before connecting to power source and/or battery pack, picking up or carrying the tool.** *Carrying power tools with your finger on the switch or energizing power tools that have the switch on invites accidents.*
- d. **Remove any adjusting key or wrench before turning the power tool on.** *A wrench or a key left attached to a rotating part of the power tool may result in personal injury.*
- e. **Do not overreach. Keep proper footing and balance at all times.** *This enables better control of the power tool in unexpected situations.*
- f. **Dress properly. Do not wear loose clothing or jewelry. Keep your hair, clothing and gloves away from moving parts.** *Loose clothes, jewelry or long hair can be caught in moving parts.*
- g. **If devices are provided for the connection of dust extraction and collection facilities, ensure these are connected and properly used.** *Use of dust collection can reduce dust-related hazards.*
- h. **Do not let familiarity gained from frequent use of tools allow you to become complacent and ignore tool safety principles.** *A careless action can cause severe injury within a fraction of a second.*
- i. Only use safety equipment that has been approved by an appropriate standards agency. Unapproved safety equipment may not provide adequate protection. Eye protection must be ANSI-approved and breathing protection must be NIOSH-approved for the specific hazards in the work area.

- j. Do not leave the tool unattended when the Battery Pack is connected. Turn off the tool, and remove the Battery Pack before leaving.
- k. This product is not a toy. Keep it out of reach of children.
- l. People with pacemakers should consult their physician(s) before use. Electromagnetic fields in close proximity to heart pacemaker could cause pacemaker interference or pacemaker failure.
- m. The warnings, precautions, and instructions discussed in this instruction manual cannot cover all possible conditions and situations that may occur. It must be understood by the operator that common sense and caution are factors which cannot be built into this product, but must be supplied by the operator.

4. Power tool use and care

- a. **Do not force the power tool. Use the correct power tool for your application.** *The correct power tool will do the job better and safer at the rate for which it was designed.*
- b. **Do not use the power tool if the switch does not turn it on and off.** *Any power tool that cannot be controlled with the switch is dangerous and must be repaired.*
- c. **Disconnect the plug from the power source and/or remove the battery pack, if detachable, from the power tool before making any adjustments, changing accessories, or storing power tools.** *Such preventive safety measures reduce the risk of starting the power tool accidentally.*
- d. **Store idle power tools out of the reach of children and do not allow persons unfamiliar with the power tool or these instructions to operate the power tool.** *Power tools are dangerous in the hands of untrained users.*
- e. **Maintain power tools and accessories. Check for misalignment or binding of moving parts, breakage of parts and any other condition that may affect the power tool's operation. If damaged, have the power tool repaired before use.** *Many accidents are caused by poorly maintained power tools.*
- f. **Keep cutting tools sharp and clean.** *Properly maintained cutting tools with sharp cutting edges are less likely to bind and are easier to control.*
- g. **Use the power tool, accessories and tool bits etc. in accordance with these instructions, taking into account the working conditions and the work to be performed.** *Use of the power tool for operations different from those intended could result in a hazardous situation.*
- h. **Keep handles and grasping surfaces dry, clean and free from oil and grease.** *Slippery handles and grasping surfaces do not allow for safe handling and control of the tool in unexpected situations.*

5. Service

- a. **Have your power tool serviced by a qualified repair person using only identical replacement parts.** *This will ensure that the safety of the power tool is maintained.*
- b. Maintain labels and nameplates on the tool. These carry important safety information. If unreadable or missing, contact Harbor Freight Tools for a replacement.

6. Safety instructions for mitre saws

- a. **Mitre saws are intended to cut wood or wood-like products, they cannot be used with abrasive cut-off wheels for cutting ferrous material such as bars, rods, studs, etc.** *Abrasive dust causes moving parts such as the lower guard to jam. Sparks from abrasive cutting will burn the lower guard, the kerf insert and other plastic parts.*
- b. **Use clamps to support the workpiece whenever possible. If supporting the workpiece by hand, you must always keep your hand at least 100 mm from either side of the saw blade. Do not use this saw to cut pieces that are too small to be securely clamped or held by hand.** *If your hand is placed too close to the saw blade, there is an increased risk of injury from blade contact.*
- c. **The workpiece must be stationary and clamped or held against both the fence and the table. Do not feed the workpiece into the blade or cut "freehand" in any way.** *Unrestrained or moving workpieces could be thrown at high speeds, causing injury.*
- d. **Push the saw through the workpiece. Do not pull the saw through the workpiece. To make a cut, raise the saw head and pull it out over the workpiece without cutting, start the motor, press the saw head down and push the saw through the workpiece.** *Cutting on the pull stroke is likely to cause the saw blade to climb on top of the workpiece and violently throw the blade assembly towards the operator.*
- e. **Never cross your hand over the intended line of cutting either in front or behind the saw blade.** *Supporting the workpiece "cross handed" i.e. holding the workpiece to the right of the saw blade with your left hand or vice versa is very dangerous.*
- f. **Do not reach behind the fence with either hand closer than 100 mm from either side of the saw blade, to remove wood scraps, or for any other reason while the blade is spinning.** *The proximity of the spinning saw blade to your hand may not be obvious and you may be seriously injured.*
- g. **Inspect your workpiece before cutting. If the workpiece is bowed or warped, clamp it with the outside bowed face toward the fence. Always make certain that there is no gap between the workpiece, fence and table along the line of the cut.** *Bent or warped workpieces can twist or shift and may cause binding on the spinning saw blade while cutting. There should be no nails or foreign objects in the workpiece.*
- h. **Do not use the saw until the table is clear of all tools, wood scraps, etc., except for the workpiece.** *Small debris or loose pieces of wood or other objects that contact the revolving blade can be thrown with high speed.*
- i. **Cut only one workpiece at a time.** *Stacked multiple workpieces cannot be adequately clamped or braced and may bind on the blade or shift during cutting.*
- j. **Ensure the mitre saw is mounted or placed on a level, firm work surface before use.** *A level and firm work surface reduces the risk of the mitre saw becoming unstable.*
- k. **Plan your work. Every time you change the bevel or mitre angle setting, make sure the adjustable fence is set correctly to support the workpiece and will not interfere with the blade or the guarding system. Without turning the tool "ON" and with no workpiece on the table, move the saw blade through a complete simulated cut to assure there will be no interference or danger of cutting the fence.**
- l. **Provide adequate support such as table extensions, saw horses, etc. for a workpiece that is wider or longer than the table top.** *Workpieces longer or wider than the mitre saw table can tip if not securely supported. If the cut-off piece or workpiece tips, it can lift the lower guard or be thrown by the spinning blade.*
- m. **Do not use another person as a substitute for a table extension or as additional support.** *Unstable support for the workpiece can cause the blade to bind or the workpiece to shift during the cutting operation pulling you and the helper into the spinning blade.*
- n. **The cut-off piece must not be jammed or pressed by any means against the spinning saw blade.** *If confined, i.e. using length stops, the cut-off piece could get wedged against them blade and thrown violently.*
- o. **Always use a clamp or a fixture designed to properly support round material such as rods or tubing.** *Rods have a tendency to roll while being cut, causing the blade to "bite" and pull the work with your hand into the blade.*
- p. **Let the blade reach full speed before contacting the workpiece.** *This will reduce the risk of the workpiece being thrown.*

- q. If the workpiece or blade becomes jammed, turn the mitre saw off. Wait for all moving parts to stop and disconnect the plug from the power source and/or remove the battery pack. Then work to free the jammed material. Continued sawing with a jammed workpiece could cause loss of control or damage to the .mitre saw.
- r. After finishing the cut, release the switch, hold the saw head down and wait for the blade to stop before removing the cut-off piece. Reaching with your hand near the coasting blade is dangerous.
- s. Hold the handle firmly when making an incomplete cut or when releasing the switch before the saw head is completely in the down position. The braking action of the saw may cause the saw head to be suddenly pulled downward, causing a risk of injury.
7. **Battery tool use and care**
- a. **Prevent unintentional starting.** Ensure the switch is in the off-position before connecting to battery pack, picking up or carrying the power tool. Carrying the power tool with your finger on the switch or energizing power tool that have the switch on invites accidents.
- b. **Disconnect the battery pack from the power tool before making any adjustments, changing accessories, or storing power tool.** Such preventive safety measures reduce the risk of starting the power tool accidentally.
- c. **Recharge only with the charger specified by the manufacturer.** A charger that is suitable for one type of battery pack may create a risk of fire when used with another battery pack.
- d. **Use power tools only with specifically designated battery packs.** Use of any other battery packs may create a risk of injury and fire.
- e. **When battery pack is not in use, keep it away from other metal objects, like paper clips, coins, keys, nails, screws or other small metal objects, that can make a connection from one terminal to another.** Shorting the battery terminals together may cause burns or a fire.
- f. **Under abusive conditions, liquid may be ejected from the battery; avoid contact.** If contact accidentally occurs, flush with water. If liquid contacts eyes, additionally seek medical help. Liquid ejected from the battery may cause irritation or burns.
- g. **Do not use a battery pack or power tool that is damaged or modified.** Damaged or modified batteries may exhibit unpredictable behavior resulting in fire, explosion or risk of injury.
- h. **Do not expose a battery pack or power tool to fire or excessive temperature.** Exposure to fire or temperature above 265°F may cause explosion.

- i. Follow all charging instructions and do not charge the battery pack or power tool outside of the temperature range specified in the instructions. Charging improperly or at temperatures outside of the specified range may damage the battery and increase the risk of fire.
- j. Have servicing performed by a qualified repair person using only identical replacement parts. This will ensure that the safety of the product is maintained.
- k. Do not modify or attempt to repair the power tool or the battery pack except as indicated in the instructions for use and care.

- l.  The battery Charger gets hot during use. The Charger's heat can build up to unsafe levels and create a fire hazard if it does not receive adequate ventilation, due to an electrical fault, or if it is used in a hot environment. Do not place the Charger on a flammable surface. Do not obstruct any vents on the Charger. **Especially avoid placing the Charger on carpets and rugs; they are not only flammable, but they also obstruct vents under the Charger.** Place the Charger on a stable, solid, nonflammable surface (such as a stable metal workbench or concrete floor) at least 1 foot away from all flammable objects, such as drapes or walls. Keep a fire extinguisher and a smoke detector in the area. Frequently monitor the Charger and Battery Pack while charging.

8. Lithium Battery Safety Warnings



LITHIUM BATTERIES STORE A LARGE AMOUNT OF ENERGY AND WILL VENT FIRE OR EXPLODE IF MISTREATED:

- a. Keep Battery Pack dry.
- b. **DO NOT DO ANY OF THE FOLLOWING TO THE BATTERY PACK:**
- Open,
 - Drop,
 - Short-circuit,
 - Puncture,
 - Incinerate, or
 - Expose to temperatures greater than 265°F.
- c. Charge Battery Pack only according to its Charger's instructions.
- d. Inspect Battery Pack before every use; do not use or charge if damaged.

9. Vibration Safety

This tool vibrates during use.

Repeated or long-term exposure to vibration may cause temporary or permanent physical injury, particularly to the hands, arms and shoulders.

To reduce the risk of vibration-related injury:

- a. Anyone using vibrating tools regularly or for an extended period should first be examined by a doctor and then have regular medical check-ups to ensure medical problems are not being caused or worsened from use. Pregnant women or people who have impaired blood circulation to the hand, past hand injuries, nervous system disorders, diabetes, or Raynaud's Disease should not use this tool. If you feel any symptoms related to vibration (such as tingling, numbness, and white or blue fingers), seek medical advice as soon as possible.
- b. Do not smoke during use. Nicotine reduces the blood supply to the hands and fingers, increasing the risk of vibration-related injury.
- c. Wear suitable gloves to reduce the vibration effects on the user.
- d. Use tools with the lowest vibration when there is a choice.
- e. Include vibration-free periods each day of work.
- f. Grip tool as lightly as possible (while still keeping safe control of it). Let the tool do the work.
- g. To reduce vibration, maintain the tool as explained in this manual. If any abnormal vibration occurs, stop use immediately.

Grounding

⚠️ WARNING







TO PREVENT ELECTRIC SHOCK AND DEATH FROM INCORRECT GROUNDING: Check with a qualified electrician if you are in doubt as to whether the outlet is properly grounded. Do not modify the power cord plug provided with the charger. Do not use the charger if the power cord or plug is damaged. If damaged, have it repaired by a service facility before use. If the plug will not fit the outlet, have a proper outlet installed by a qualified electrician.

Extension Cords

Note: Extension cords must not be used with this item's Charger.

Symbology

V	Volts		WARNING marking concerning Risk of Fire. Do not cover Charger ventilation ducts. Charge on fireproof surface only.
≡	Direct Current		WARNING marking concerning Risk of Electric Shock. Properly connect Charger's power cord to appropriate outlet.
A	Amperes		WARNING marking concerning Risk of Explosion. Do not puncture, short, or open battery packs and do not charge damaged battery packs.
n ₀ xxxx/min.	No Load Revolutions per Minute (RPM)		
	WARNING marking concerning Risk of Eye Injury. Wear ANSI-approved safety goggles with side shields.		
	Read the manual before set-up and/or use.		

Bauer[™]

Specifications

Charger Type	Bauer 20V Li-ion 63947, 63529, 57006 (sold separately)
Battery Type	Bauer 20V Li-ion 64816, 64817, 57007 (sold separately)
Rated No Load Speed	n_0 3800/min
Cutting Capacity at 45° L	2-1/2" x 6-1/8"
Cutting Capacity at 90° L/R	2-1/2" x 8-5/8"
Maximum Bevel	47° Left
Maximum Miter	47° Left and Right
Saw Blade	7-1/4" Diameter, up to 0.1" Wide (Kerf), 5/8" Round Arbor Bore, 3800 Minimum RPM Rating

Setup - Before Use:



Read the **ENTIRE IMPORTANT SAFETY INFORMATION** section at the beginning of this manual including all text under subheadings therein before set up or use of this product.

Note: For additional information regarding the parts listed in the following pages, refer to *Parts List and Diagram* on page 18.

Mounting

1. Use the four bolt holes provided in the Base to mount the Miter Saw to a stable support before use. Mounting hardware not included.
2. Ensure that the Miter Saw is always stable and secure (e.g. fixed to a bench).

Assembly

1. Squeeze the metal collar wings on the Dust Collection Bag.
2. Slide the Dust Collection Bag over the Dust Outlet at the rear of the Saw Head Assembly and release the metal collar wings.

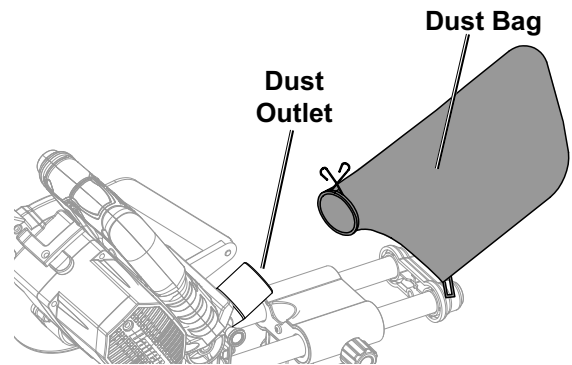

Note: There are two mounting holes for the Clamp, shown here. Choose the mounting hole that is more appropriate for your work.

3. Place Clamp into desired mounting hole.
4. Rotate Clamp Knob either clockwise or counterclockwise to move Clamp up or down.

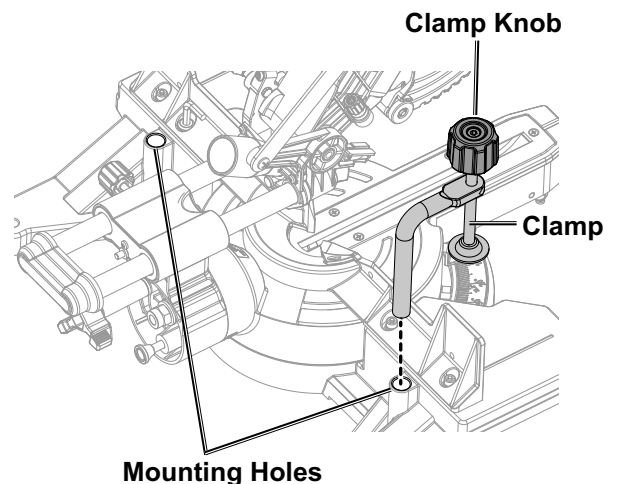

Charging

Charge battery before using this tool. Follow instructions included with battery charger (sold separately).

Functions

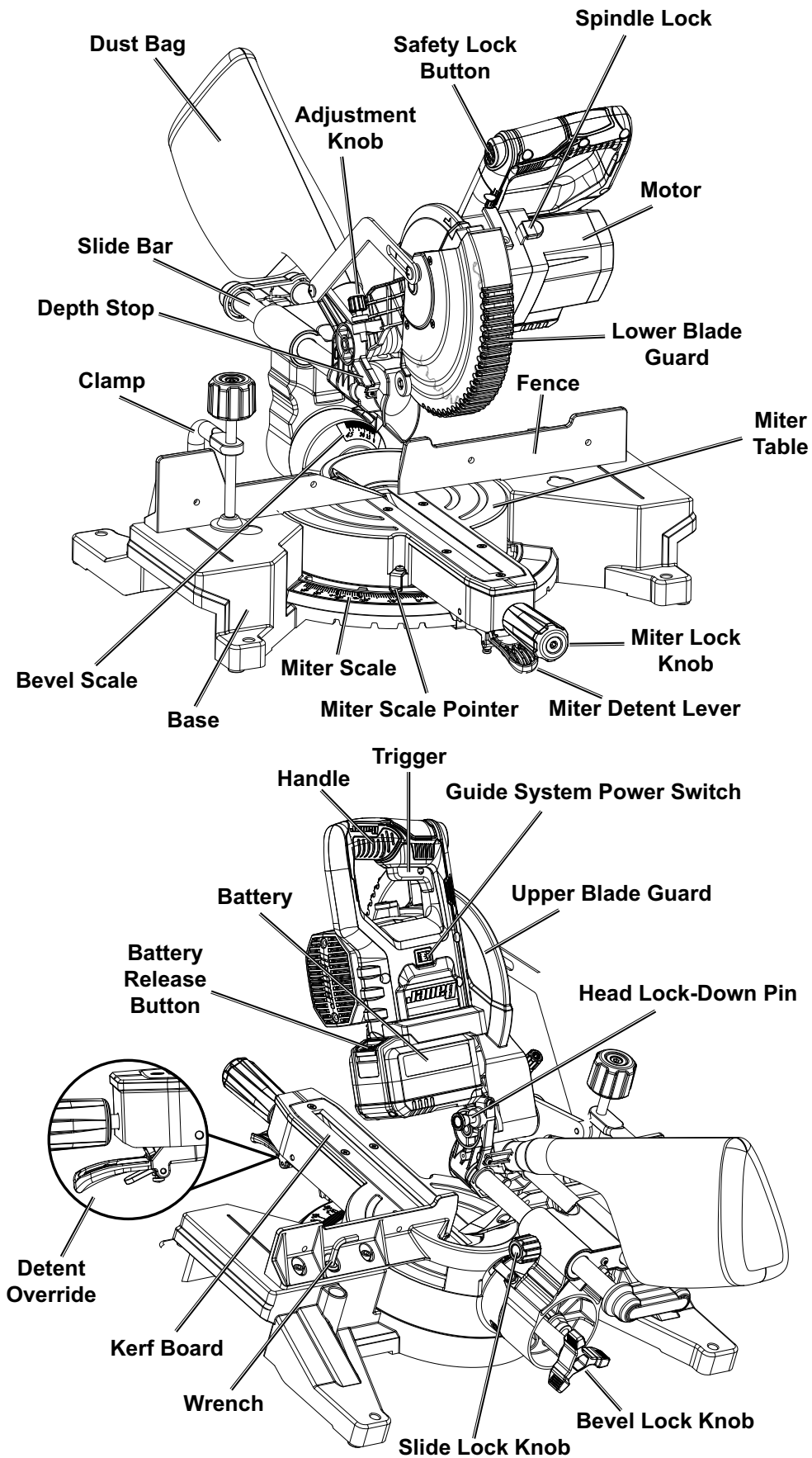

SAFETY

SETUP

OPERATION

MAINTENANCE

Work Area

1. Designate a work area that is clean and well lit. The work area must not allow access by children or pets to prevent distraction and injury.
2. There must not be objects, such as utility lines, nearby that will present a hazard while working.

Saw Blade Selection

1. Any saw blade that will be used must be marked as suitable for the material to be cut.
2. Use only a saw blade diameter in accordance with the markings on the saw. See specification table for the bore diameter and the maximum kerf of the saw blade.
3. Use only saw blades that are marked with a speed equal or higher than the speed marked on the tool.

Guard Setup

Check that the Lower Blade Guard is in place, moves freely, and closes instantly.

Dust Extraction Setup

1. To use the Dust Collection Bag, slide the Bag over the Dust Outlet at the rear of the Saw Head Assembly. Refer to *Assembly* on page 8.
2. Connect a dust extraction device to the Dust Outlet to use a dust collection system instead of the Dust Bag.

The logo for Bauer, featuring the word "Bauer" in a bold, italicized, sans-serif font with a trademark symbol (TM) at the end.

Operating Instructions



Read the **ENTIRE IMPORTANT SAFETY INFORMATION** section at the beginning of this manual including all text under subheadings therein before set up or use of this product.

Tool Changing

Note: Blade sold separately.

1. Remove Battery.
2. Raise the Lower Blade Guard out of the way and hold it up.
3. Loosen the Guard Plate Bolt until it disengages the Guard Plate.
4. Swing the Guard Plate up and out of the way.
5. Press in the Spindle Lock on the back of the saw's head and hold it in.

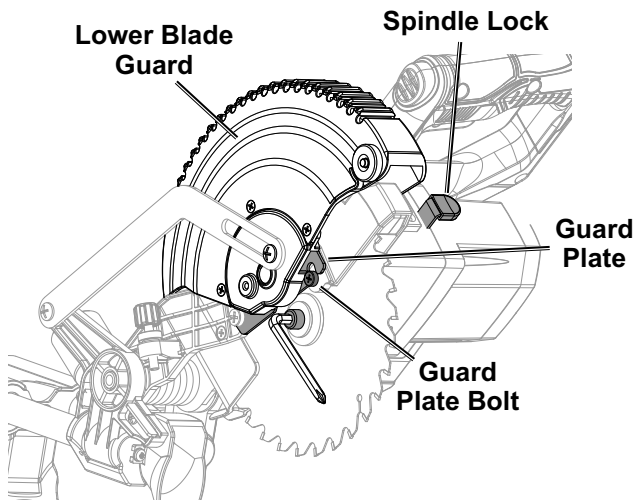

6. Remove the Arbor Bolt, Flat Washer and Outer Flange.
IMPORTANT: The Arbor Bolt has a left-handed thread and removes by turning CLOCKWISE.

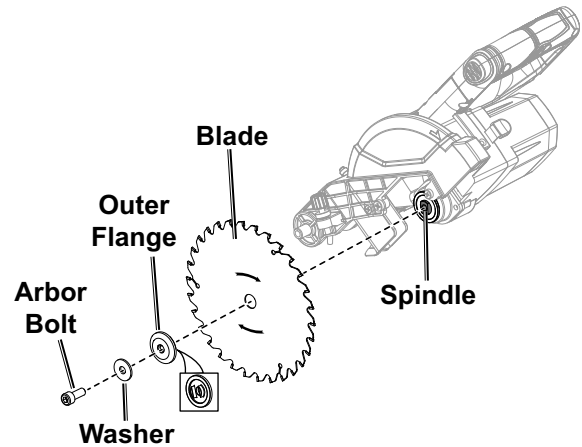

Note: Make sure the Inner Flange stays in place on the Spindle.

7. Install the new Blade. **Make sure that the Blade's rotation arrow points in the same direction as the rotation arrow on the Upper Blade Guard.**
8. Replace the Outer Flange and Arbor Bolt. Position the cupped side of the Flange against the Blade. Hold in the Spindle Lock and wrench tighten the Arbor Bolt by turning it **COUNTERCLOCKWISE**. Release the Spindle Lock.
9. Rotate the Guard Plate back into place, and secure it with the Guard Plate Bolt.
10. **WARNING! TO PREVENT SERIOUS INJURY: Make sure the Lower Blade Guard operates smoothly and properly protects from the Blade before using the Saw.**

Setting and Testing

SAFETY

SETUP

OPERATION

MAINTENANCE

⚠WARNING

TO PREVENT SERIOUS INJURY FROM ACCIDENTAL OPERATION:
Make sure that the Trigger is in the off-position and remove its Battery Pack before performing any procedure in this section.

Adjusting the Miter Angle

A miter cut is one that is at an angle across the horizontal surface of the material. 45° miter cuts to join two pieces in a right angle corner are common. A 30° cut is often used for a scarf joint or to make a chamfered end.

1. Loosen the Miter Lock Knob by turning it counterclockwise to unlock the Miter Table. Push down on the Miter Detent Lock Lever and move the Table to the desired angle.
2. The Miter Angle Indicator will indicate the selected angle. When the Miter Detent Lock Lever is released, the Table will lock into place at often used miter angles, including 0°, 15°, 22.5°, 30°, 31.6°, 45° and 48° left on both left and right sides.

3. To override the pre-set detents (stops) for micro adjustments at any angle, push down and hold the Miter Detent Lock Lever and adjust Table to any position on the miter scale.

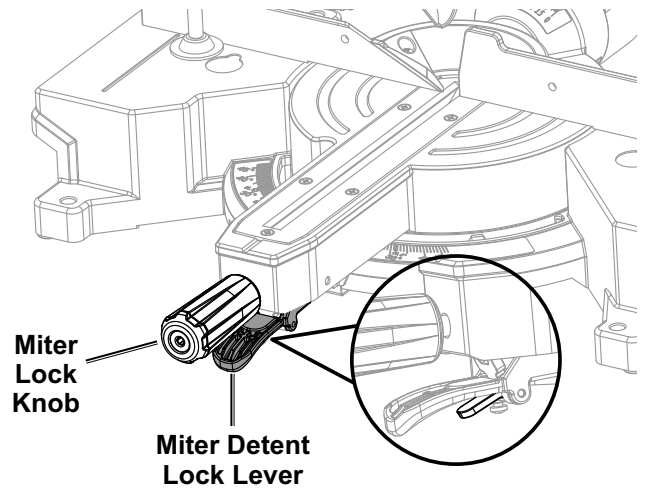

4. Tighten the Miter Lock Knob after adjusting the miter angle.
5. With the Table adjusted to the desired angle, place the workpiece flush against the Fence, secure it with the Clamp and make the cut.

Adjusting the Bevel Angle

A bevel cut is one that is at an angle vertically. Bevel cuts can be used to miter relatively wide and thin material. Bevel cuts can be used in combination with a miter cut to form a compound angle. Compound angle cuts are often used in crown moldings, picture frames and similar trim materials.

1. Loosen the Bevel Lock Knob at the rear of the saw to unlock the Saw Head Assembly.
2. To adjust the left bevel angle between 0° and 45°, move the Saw Head Assembly to the left to the desired angle. Read the angle on the Bevel Scale.
3. Press the Bevel Angle Lock Button during adjustment to also set angles up to 48° left bevel angle or up to 3° right bevel angle.
4. Lock the Saw Head Assembly into position by rotating the Bevel Lock Knob clockwise. Tighten firmly but do not over-tighten.

5. Make a sample cut in a piece of scrap to confirm that the bevel angle is correct. If it is not, correct the angle before cutting.

WARNING! TO PREVENT SERIOUS INJURY:
Adjust the Sliding Fence clear of the Blade's cutting path after making any adjustment to the cutting angle. Move the Blade through its full range of motion to ensure the Fence is clear.

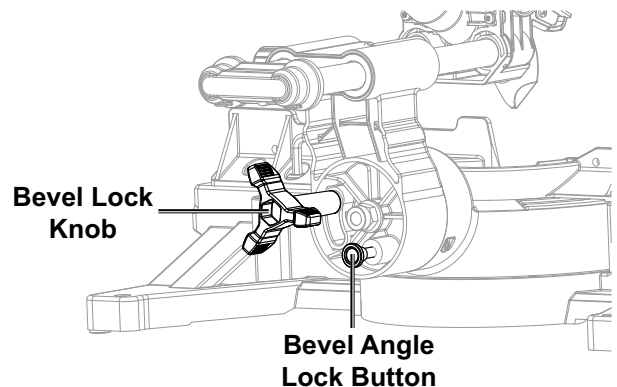

Aligning the Fence

1. After adjusting the miter or bevel setting, check and adjust the Sliding Fence.
2. Loosen the Fence Lock Knob, and move the Sliding Fence to be within 1/8" of the blade.
3. Tighten the Fence Lock Knob. Make sure that the Sliding Fence still does not contact the Blade.

Kerf Board Replacement/Adjustment

If the Kerf Board becomes damaged it must be replaced.

1. Remove the five screws holding the Kerf Board in place and lift it from the Saw.
2. Install the new Kerf Board, with the left and right sides on either side of the cut line. Replace the five screws and tighten the screws slightly.

To adjust the Kerf Board:

1. Check for blade clearance by moving the Saw Head through its full range of motion with the bevel angle set at 0° and at maximum left bevel angle. Refer to *Adjusting the Bevel Angle on page 12*.
2. If the Saw Blade hits either side of the Kerf Board, loosen the screws for that side and adjust. Tighten the screws and check again for blade clearance.

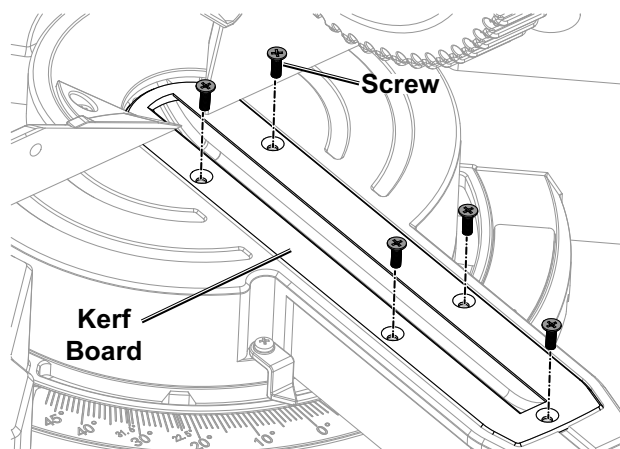

3. After verifying blade clearance, tighten the screws holding the Kerf Board in place.

Using the Blade Guide System

This Saw features a Blade Guide System that casts the shadow of the blade onto the workpiece. This provides greater accuracy when cutting.

1. Press the Power Switch, located above the Battery Pack, to activate the Guide System.
2. Lower the Saw Head Assembly so that the blade is 1/4 inches from the workpiece. The shadow of the blade will appear on the workpiece, showing where the blade teeth will make contact as the cut is made.

Blade Guide Power Switch

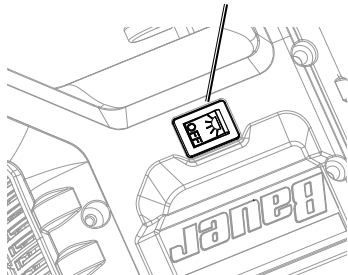

Workpiece Set Up

1. Secure loose workpieces using a vise or clamps (not included) to prevent movement while working.
2. Cut only the following materials:
Dimensional lumber, plywood, particle board, plastic.
3. Refer to cutting capacities in the *Specifications Table* on page 8 for limitations on workpiece size.
4. Allow room on both left and right sides of Saw for extended workpieces.
5. Use additional supports if needed to ensure the stability of the workpiece. Mount the Saw so that the surface is level to the ground, and additional supports to provide a surface on the same level as the saw table. If the work surface and any workpiece supports are not level, and on the same level, unwanted bevel angles will appear in the cuts resulting in poor joinery.
6. Secure workpieces to the saw table using the Clamp or other clamping devices (not included). Securing the workpiece will provide safety by preventing kick back and by removing the need to hold workpieces near the blade by hand. Clamping the workpiece will also improve cutting accuracy by preventing the workpiece from moving during the cutting operation.

General Instructions for Use

SAFETY

1. Make sure that the Trigger is in the off-position, then attach the Battery Pack.

WARNING! TO PREVENT SERIOUS INJURY:

The tool will restart automatically if stalled.

Sliding Miter Saw Cutting Procedure

2. Unlock the Head Lock-Down Pin.
3. Check that all adjustment knobs are tight (Miter Lock Handle, Bevel Lock Handle, Fence Lock Knobs, and Table Extension Lock Levers).
4. Blow any sawdust or debris away from the Fence. Place the work material against the Fence.
5. To use the Shadow Cut Line Guide System to align the cut, turn its Switch on. Pull the Saw Head down until the Saw Blade is close to the workpiece and the Blade's shadow appears on the work material, indicating where the Blade will cut. Align the marked location of the cut on the workpiece with the edge of the Saw Blade shadow.
6. The Saw will also operate without using the Shadow Cut Line Guide System if desired. In that case align the marked location of the cut on the work material with the saw blade. To prevent the workpiece from being cut too short, align the edge of the blade with the measured mark, keeping the rest of the blade on the waste side of the cut.
7. Hold the work material in place using the Clamp. Ensure that the work material is level and supported securely. Use saw horses or supports if necessary.



DANGER! Saws can quickly amputate fingers if misused. Keep hands well clear of cutting area.

SETUP

OPERATION

MAINTENANCE

8. Grip the Saw Handle, press the Trigger Lock Button with your thumb, and squeeze the Trigger to start the Saw.
9. Use two hands and hold workpiece securely against table and fence at all times.
10. With narrow material, press down lightly to cut the workpiece. Press straight down, "chopping" the material. Do not bear down on the material—use light downward pressure. If the material binds the blade, release the Trigger.
11. With wide material, move the Blade across the workpiece while cutting as follows:
 - a. Loosen Slide Lock Knob and pull Saw Head Assembly forward.
 - b. Press down on the Saw Handle.
 - c. Push the Saw Head toward the rear to make the cut.Do not bear down on the material—use light downward and lateral pressure. If the material binds the blade, release the Trigger.
12. When the cut is completed, raise the Saw Head, release the Trigger, wait for the Blade to stop turning, release the Clamp and remove the workpiece from the Saw.
13. To prevent accidents, turn off the tool and remove its Battery Pack after use. Clean, then store the tool indoors out of children's reach.
14. Lock the Saw Head down and lock all other adjustments before moving the Saw. Use the Carrying Handle and handle cut outs on each side of the Base to lift and support the Saw while moving it.

Maintenance and Servicing Instructions



Procedures not specifically explained in this manual must be performed only by a qualified technician.

WARNING

TO PREVENT SERIOUS INJURY FROM ACCIDENTAL OPERATION:
Make sure that the Trigger is in the off-position and remove its Battery Pack before performing any procedure in this section.

TO PREVENT SERIOUS INJURY FROM TOOL FAILURE:
Do not use damaged equipment. If abnormal noise or vibration occurs, have the problem corrected before further use.

Cleaning, Maintenance, and Lubrication

- BEFORE EACH USE**, inspect the general condition of the tool. Check for:
 - leaking, swollen, or cracked battery pack,
 - loose hardware
 - misalignment or binding of moving parts
 - cracked or broken parts
 - any other condition that may affect its safe operation.
- AFTER USE**, wipe external surfaces of the tool with clean cloth. Carefully clean the dust collection chute and the area around the Lower Blade Guard. Check that the Lower Blade Guard moves smoothly through its entire range of movement, without sticking.
- Periodically, wear ANSI-approved safety goggles and NIOSH-approved breathing protection and blow dust out of the motor vents using dry compressed air.
- Li-Ion BATTERY MUST BE RECYCLED OR DISPOSED OF PROPERLY. Do not short, incinerate or open battery.
- Disconnect battery pack and store battery pack, charger, and tool in dry, indoor area out of reach of children and away from metal objects (i.e., paperclips, coins) to prevent shorting.

Checking and Calibrating the Fence

The Fence holds the workpiece in a fixed position while the Table and/or the Saw Head Assembly are adjusted in a miter or bevel angle.

To make accurate cuts, the Fence must be perpendicular (at a 90° angle) to the Saw Blade.

- Before beginning work, make a test cut on scrap material with the Table set to the 0° miter position.
- Check the cut with an accurate square. You can also reverse the two pieces, hold the cut ends together, and hold a good straight edge along the side of the pieces.
- If either test reveals that the cut is not a true 90° angle, adjust the Fence before beginning work.

If Fence needs adjustment:

- First remove battery.
- Set the bevel and miter angles to the 0° position.
- Lower the Saw Head Assembly and lock it in place using the Head Lock-Down Pin.

- Lay a carpenter's square on the Table with one edge along the Blade and the other along the Fence. Any inaccuracy should be visible.

NOTE: The square must contact the surface of the blade, not the teeth, for an accurate reading.

- The Fence is held in place with four Fence Adjusting Bolts. Loosen the Bolts slightly, and gently tap the Fence into position using a soft mallet. Tighten the Bolts and make another test cut. Repeat the process until the Fence is adjusted accurately.

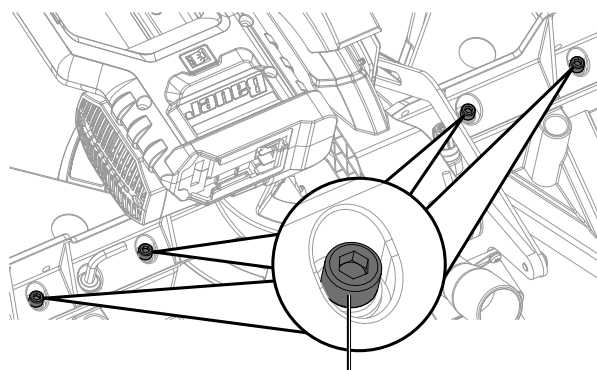

Fence Adjusting Bolt

Calibrating the Bevel Angle

For making accurate cuts, the Saw Blade must be adjusted to be exactly vertical to the Table.

1. To check the angle, have the Saw Head Assembly in its normal upright position and set to the 0° bevel position. Make a cut on a piece of flat sided, fairly thick scrap material.
2. Check the cut with an accurate square. The cut should be at exactly 90°.
3. Angle can also be checked by rotating one cut-off piece 180° and holding the cut ends together. If the cut is not exactly vertical, the two pieces will form a slight angle.

0° Bevel Angle Adjustment

1. First remove battery.
2. Set the Miter Table at 0°.
3. Loosen the Bevel Lock Knob, move the Saw Head Assembly until the Bevel Angle Indicator is at 0° on the Bevel Scale, then tighten the Bevel Lock Knob.
4. Pull down the Saw Head until the Blade just enters the Kerf Board.
5. Place a framing square on the Miter Table and up against the Saw Blade.

NOTE: The square must contact the surface of the Blade, not the teeth, for an accurate reading.

6. If the Blade is not 90° square with the Miter Table, loosen the Bevel Lock Knob, tilt the Saw Head completely to the left, loosen the Lock Nut on the 0° Bevel Angle Adjustment Bolt and adjust the Bolt in or out with a hex key to increase or decrease the bevel angle.
7. Tilt the Saw Head back to the right at 0° bevel and recheck for alignment.
8. After alignment is achieved, tighten the Bevel Lock Knob and Adjustment Bolt Lock Nut.

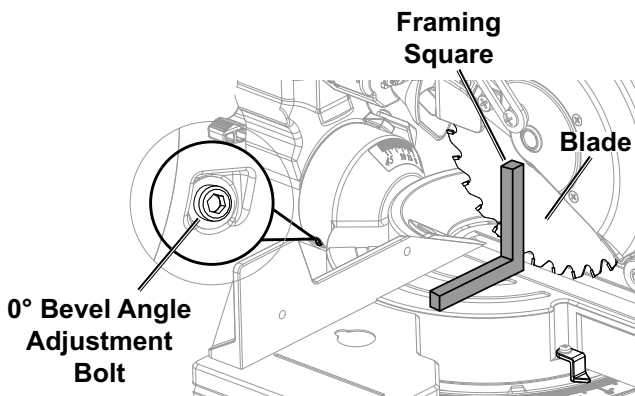

WARNING! TO PREVENT SERIOUS INJURY: Adjust the Sliding Fence clear of the Blade's cutting path after making any adjustment to the cutting angle. Move the Blade through its full range of motion to ensure the Fence is clear.

45° Bevel Angle Adjustment

Adjust the 45° bevel angle only after performing the 0° bevel angle adjustment.

9. Loosen the Bevel Lock Knob,
10. Move the Saw Head to the left until the Bevel Angle Indicator is at 45° on the Bevel Scale.
11. Pull down the Saw Head until the Blade just enters the Kerf Board.
12. Place a triangle square on the Miter Table and up against the Saw Blade.

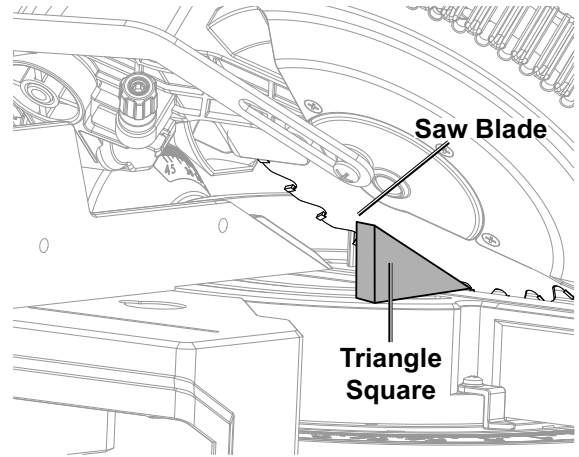

13. If the Blade is not 45° with the Miter Table, tilt the Saw Head to the right, loosen the Lock Nut on the 45° Bevel Angle Adjustment Bolt and adjust the Bolt in or out with a hex key to increase or decrease the bevel angle.
14. Tilt the Saw Head back to the left at 45° bevel and recheck for alignment.
15. After alignment is achieved, tighten the Bevel Lock Knob and Adjustment Bolt Lock Nut.

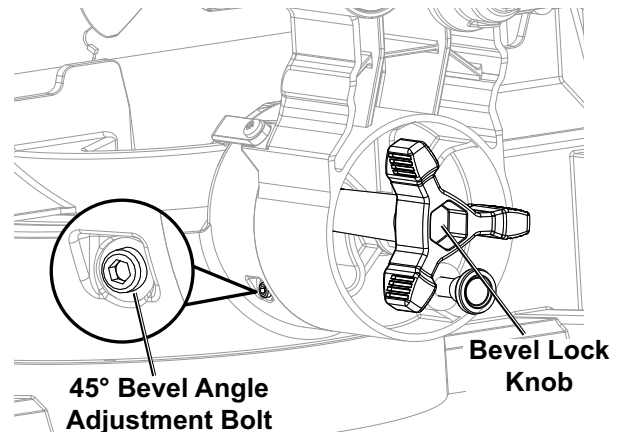

Calibrating the Miter Angle Indicator

Check the accuracy of the Miter Angle Indicator only after checking or adjusting the Fence to confirm that it is at 90° to the Saw Blade.

1. Position the Miter Table at 0°.

2. Loosen the Adjustment Screw holding the Miter Angle Indicator in place.
3. Adjust the red line on the Miter Angle Indicator to the 0° mark on the Miter Scale.
4. Retighten the Screw.

Troubleshooting

Problem	Possible Causes	Likely Solutions
Tool will not start.	<ol style="list-style-type: none"> 1. Battery Pack not properly connected. 2. Battery Pack not properly charged. 3. Battery Pack burnt-out. 4. Internal damage or wear. (Trigger, for example.) 	<ol style="list-style-type: none"> 1. Remove Battery Pack, make sure there are no obstructions, reinsert the Battery Pack according to its shape (it should only fit one way), and press firmly until the Battery Pack locks in place. 2. Make sure Charger is connected and operating properly. Give enough time for Battery Pack to recharge properly. 3. Dispose of old Battery Pack properly or recycle. Replace Battery Pack. 4. Have technician service tool.
Tool operates slowly.	<ol style="list-style-type: none"> 1. Forcing tool to work too fast. 2. Battery Pack wearing out. 	<ol style="list-style-type: none"> 1. Allow tool to work at its own rate. 2. Dispose of old Battery Pack properly or recycle. Replace Battery Pack.
Excessive noise or rattling.	Internal damage or wear. (Bearings, for example.)	Have technician service tool.
Overheating.	<ol style="list-style-type: none"> 1. Forcing tool to work too fast. 2. Blocked motor housing vents. 	<ol style="list-style-type: none"> 1. Allow tool to work at its own rate. 2. Wear ANSI-approved safety goggles and NIOSH-approved dust mask/respirator while blowing dust out of motor using compressed air.



Follow all safety precautions whenever diagnosing or servicing the tool. Disconnect Battery Pack and Charger power supply before service.

Record Product's Serial Number Here: _____

Note: If product has no serial number, record month and year of purchase instead.

Note: Some parts are listed and shown for illustration purposes only, and are not available individually as replacement parts. Specify UPC 193175425768 when ordering parts.

Parts List

SAFETY

SETUP

OPERATION

MAINTENANCE

Part	Description	Qty
1	Base	1
2	Absorber Pad	4
3	Miter Scale Label	1
4	Flat Washer	1
5	Locknut	1
6	Clamp Knob	1
7	Clamp	1
8	Clamping Plate	1
9	Flat Washer	1
10	Spring Washer	3
11	Pan Head Screw	11
12	Fence	1
13	Flat Washer	4
14	Spring Washer	4
15	HS Bolt	4
16	Wrench Storage	1
17	Wrench	1
18	Fence Adaptor	1
19	Self-Tapping Screw	2
20	Detent Override	1
21	Spring	1
22	Pin	1
23	Miter Detent Lever	1
24	Adjustable Foot	1
25	Spring	1
26	Flat Washer	7
27	Plate	1
28	Friction Plate	4
29	HS Bolt	2
30	Spring Washer	2
31	Flat Washer	2
32	Miter Setting Plate	1
33	HS Bolt	1
34	Ring	3
35	HS Setting Screw	3
36	Shaft	1
37	Orientation Pin	1
38	Spring	1
39	Arm	1
40	Flat Washer	1
41	Locknut	1
42	Knob	2
43	Bevel Lock Knob	1
44	Bar Connection Bracket	1
45	Elastic Pin	4
46	Cushion	2
47	Slide Bar	2
48	Wool Felt	4
49	Bearing End Cover	1
50	Linear Bearing	3
51	Bearing Bush	2
52	Slide Lock Knob	1
53	Spring	1

Part	Description	Qty
54	Bevel Pointer	1
55	Bearing End Cover	1
56	Cross Sunk Head Screw	5
57	Kerf Board	1
58	Hex Bolt	1
59	Bevel Scale Label	1
60	Miter Pointer	1
61	Miter Table	1
62	Pin	1
63	Miter Lock Knob	1
64	Handle Cap	1
65	Dust Collection Plate	1
66	HS Setting Screw	1
67	Pin	1
68	Ring	1
69	Blade Guard Bracket	1
70	Depth Plate	1
71	Wave Ring	1
72	Screw	1
73	Shaft	1
74	Dust Outlet	1
75	Lower Blade Guard	1
76	Guard Wheel	1
77	Ring	1
78	Cross Sunk Head Screw	3
79	Screw	2
80	Link Plate	1
81	Square Neck Bolt	1
82	Guard Cover	1
83	Torsion Spring	1
84	Guard Plate Bolt	1
85	Elastic Pin B	1
86	Screw	1
87	Guard Plate	1
88	Flat Washer	1
89	Locknut	1
90	Arbor Bolt	1
91	Flat Washer	1
92	Outer Flange	1
93	Saw Blade (Sold Separately)	1
94	Inner Flange	1
95	Cross Sunk Head Screw	2
96	Knob	1
97	M6 Knurl Nut	1
98	Sleeve	1
99	Spring	1
100	Cover	1
101	Lock Plate	1
102	Square Nut	1
103	Bolt	1
104	Spring Washer	1
105	Motor Assembly	1

Assembly Diagram

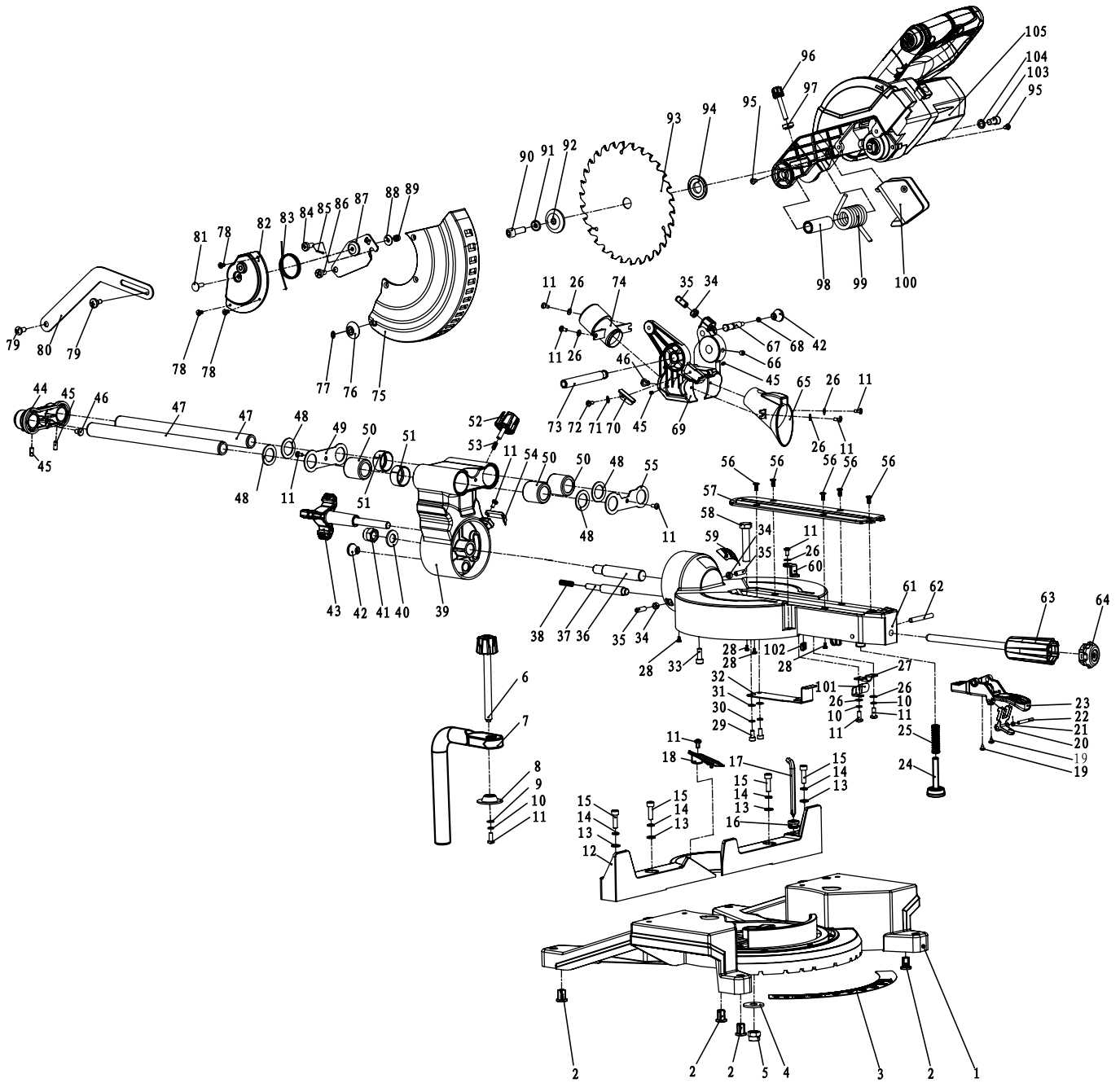

SAFETY

SETUP

OPERATION

MAINTENANCE

PLEASE READ THE FOLLOWING CAREFULLY

THE MANUFACTURER AND/OR DISTRIBUTOR HAS PROVIDED THE PARTS LIST AND ASSEMBLY DIAGRAM IN THIS MANUAL AS A REFERENCE TOOL ONLY. NEITHER THE MANUFACTURER OR DISTRIBUTOR MAKES ANY REPRESENTATION OR WARRANTY OF ANY KIND TO THE BUYER THAT HE OR SHE IS QUALIFIED TO MAKE ANY REPAIRS TO THE PRODUCT, OR THAT HE OR SHE IS QUALIFIED TO REPLACE ANY PARTS OF THE PRODUCT. IN FACT, THE MANUFACTURER AND/OR DISTRIBUTOR EXPRESSLY STATES THAT ALL REPAIRS AND PARTS REPLACEMENTS SHOULD BE UNDERTAKEN BY CERTIFIED AND LICENSED TECHNICIANS, AND NOT BY THE BUYER. THE BUYER ASSUMES ALL RISK AND LIABILITY ARISING OUT OF HIS OR HER REPAIRS TO THE ORIGINAL PRODUCT OR REPLACEMENT PARTS THERETO, OR ARISING OUT OF HIS OR HER INSTALLATION OF REPLACEMENT PARTS THERETO.

Limited 90 Day Warranty

Harbor Freight Tools Co. makes every effort to assure that its products meet high quality and durability standards, and warrants to the original purchaser that this product is free from defects in materials and workmanship for the period of 90 days from the date of purchase. This warranty does not apply to damage due directly or indirectly, to misuse, abuse, negligence or accidents, repairs or alterations outside our facilities, criminal activity, improper installation, normal wear and tear, or to lack of maintenance. We shall in no event be liable for death, injuries to persons or property, or for incidental, contingent, special or consequential damages arising from the use of our product. Some states do not allow the exclusion or limitation of incidental or consequential damages, so the above limitation of exclusion may not apply to you. THIS WARRANTY IS EXPRESSLY IN LIEU OF ALL OTHER WARRANTIES, EXPRESS OR IMPLIED, INCLUDING THE WARRANTIES OF MERCHANTABILITY AND FITNESS.

To take advantage of this warranty, the product or part must be returned to us with transportation charges prepaid. Proof of purchase date and an explanation of the complaint must accompany the merchandise. If our inspection verifies the defect, we will either repair or replace the product at our election or we may elect to refund the purchase price if we cannot readily and quickly provide you with a replacement. We will return repaired products at our expense, but if we determine there is no defect, or that the defect resulted from causes not within the scope of our warranty, then you must bear the cost of returning the product.

This warranty gives you specific legal rights and you may also have other rights which vary from state to state.

The logo for Bauer, featuring the word "Bauer" in a bold, italicized, sans-serif font. The letters are black with a white outline, and a small trademark symbol (TM) is located at the bottom right of the word.

26677 Agoura Road • Calabasas, CA 91302 • 1-888-866-5797