

Owner's Manual & Safety Instructions

Save This Manual Keep this manual for the safety warnings and precautions, assembly, operating, inspection, maintenance and cleaning procedures. Write the product's serial number in the back of the manual near the assembly diagram (or month and year of purchase if product has no number). Keep this manual and the receipt in a safe and dry place for future reference.

201

TITANIUM™

TI-TCWH7

58058



Visit our website at: <http://www.harborfreight.com>
Email our technical support at: productsupport@harborfreight.com

When unpacking, make sure that the product is intact and undamaged. If any parts are missing or broken, please call 1-888-866-5797 as soon as possible.

Copyright© 2020 by Harbor Freight Tools®. All rights reserved.
No portion of this manual or any artwork contained herein may be reproduced in any shape or form without the express written consent of Harbor Freight Tools. Diagrams within this manual may not be drawn proportionally. Due to continuing improvements, actual product may differ slightly from the product described herein. Tools required for assembly and service may not be included.

⚠ WARNING

Read this material before using this product. Failure to do so can result in serious injury. **SAVE THIS MANUAL.**

Table of Contents

Safety	2	Maintenance and Servicing	9
Specifications	4	Parts List and Diagram	11
Operation	6	Warranty	12





SAFETY

SPECIFICATIONS

OPERATION

MAINTENANCE

WARNING SYMBOLS AND DEFINITIONS

	This is the safety alert symbol. It is used to alert you to potential personal injury hazards. Obey all safety messages that follow this symbol to avoid possible injury or death.
	Indicates a hazardous situation which, if not avoided, will result in death or serious injury.
	Indicates a hazardous situation which, if not avoided, could result in death or serious injury.
	Indicates a hazardous situation which, if not avoided, could result in minor or moderate injury.
	Addresses practices not related to personal injury.

IMPORTANT SAFETY INFORMATION

When using helmet, basic safety precautions should always be followed to reduce the risk of personal injury and damage to equipment.

The warnings, cautions, and instructions discussed in this instruction manual cannot cover all possible conditions and situations that may occur. It must be understood by the operator that common sense and caution are factors which cannot be built into this product, but must be supplied by the operator.

Read all instructions before using this helmet!

1. **Do not use the Welding Helmet if the lens is cracked, if the lens or sensors are dirty, or if the lens or front retaining frame is loose.**
2. **Keep work area clean.** Cluttered areas invite injuries.
3. **Observe work area conditions.** Do not use welding helmets in damp or wet locations. Do not expose to rain. Keep work area well lit. Do not use auto-darkening helmets in the presence of flammable gases or liquids.
4. **Keep children away.** Children must never be allowed in the work area. Do not let them handle this helmet. Dress properly. Do not wear loose clothing or jewelry. Keep your hair, clothing and gloves away from moving parts.
5. **Store idle equipment.** When not in use, helmets must be stored in a dry location to inhibit rust. Always lock up helmets and keep out of reach of children.
6. **Dress properly.** Do not wear loose clothing or jewelry as they can be caught in moving parts. Protective gear is essential to protect against welding rays, some examples are: a leather welding apron, welding sleeves, jeans without cuffs, work boots. Wear restrictive hair covering to contain long hair.
7. **Use breathing and hearing protection.** Wear a NIOSH-approved respirator and hearing protection when welding.
8. **Stay alert.** Watch what you are doing, use common sense. Do not weld when you are tired.
9. **Do not weld if under the influence of alcohol or drugs.** Read warning labels on prescriptions to determine if your judgment or reflexes are impaired while taking drugs. If there is any doubt, do not weld.

⚠️ WARNING



INHALATION HAZARD: Welding and Plasma Cutting Produce TOXIC FUMES.

Exposure to welding or cutting exhaust fumes can increase the risk of developing certain cancers, such as cancer of the larynx and lung cancer. Also, some diseases that may be linked to exposure to welding or plasma cutting exhaust fumes are:

- Early onset of Parkinson's Disease
- Heart disease
- Damage to the reproductive organs
- Inflammation of the small intestine or stomach
- Respiratory diseases such as emphysema, bronchitis, or pneumonia
- Ulcers
- Kidney damage

Use natural or forced air ventilation and wear a respirator approved by NIOSH to protect against the fumes produced to reduce the risk of developing the above illnesses.

10. **Check for damaged parts.** Before using any helmet, any part that appears damaged should be carefully checked to determine that it will operate properly and perform its intended function. Check for alignment and binding of moving parts; any broken parts or mounting fixtures; and any other condition that may affect proper operation. Any part that is damaged should be properly repaired or replaced by a qualified technician. Do not use the helmet if any switch does not operate properly.
11. **Replacement parts and accessories.** When servicing, use only identical replacement parts. Use of any other parts can render helmet ineffective, possibly causing eye damage, and will void the warranty. Only use accessories intended for use with this helmet. Approved accessories are available from Harbor Freight Tools.
12. **Maintenance.** For your safety, service and maintenance should be performed regularly only by a qualified technician.

13. **This helmet provides protection for intended purposes only.** There are certain applications for which this helmet was designed. Do not modify this helmet and do not use this helmet for a purpose for which it was not intended:
 - a. **The Welding Helmet** is not suitable for laser welding.
 - b. **The Welding Helmet** will not protect against severe impact hazards.
 - c. **The Welding Helmet** will not protect against explosive devices or corrosive liquids.
14. **Use only at temperatures within the operating range for your model as stated on the specifications chart in this manual.**
15. Maintain the helmet and lens correctly to help ensure reliable protection:
 - a. Clean filter's surfaces regularly. Keep sensors and solar cells clean using a clean lint-free tissue/cloth. Do not use any solvents on filter's screen or helmet components. Protect filter from liquid and dirt contact. Do not immerse the filter in water.
 - b. Should the Auto-Darkening Welding Helmet not darken upon striking an arc, stop welding immediately and have the helmet checked by a qualified service technician.
 - c. Regularly replace the Front Lens Cover if it becomes cracked, scratched, pitted, or otherwise damaged.
 - d. Do not make any modifications to either the Auto-Darkening Filter or the rest of the helmet, other than those specified in this manual. Do not use any replacement parts other than those specified in this manual. Unauthorized modifications and replacement parts will void the warranty and expose the user to the risk of personal injury. Do not open or tamper with the Auto-Darkening Filter.
16. Do not place the Welding Helmet's Auto-Darkening Filter on a hot surface.
17. **SEVERE PERSONAL INJURY and/or BLINDNESS may occur if the user fails to follow the aforementioned warnings and/or fails to follow the operation instructions.**
18. Maintain labels and nameplates on the tool. These carry important safety information. If unreadable or missing, contact Harbor Freight Tools for a replacement.



SAVE THESE INSTRUCTIONS.

Specifications

Description	Auto-Darkening Welding Helmet
Power Source	Solar powered cell with battery assistance (replaceable 3V CR2450 lithium battery)
Operating Temperature	14° to 149° F
Resting Shade	Shade #3
Shade Range	5 to 9 – 9 to 13 variable
UV/IR Protection	Up to DIN 15 at all times
Lens Type	ANSI Z87.1-2020 compliant
Viewing Area	1.84" L x 3.81" W (7.1 sq. in.)
Welding Protection Types	For all arc welding processes including MIG/Flux welding, stick welding, TIG welding (2+ amps), plasma arc welding/cutting, Oxyacetylene welding/cutting and air carbon cutting. Not for Laser Welding.
Lens Switching Speed (Clear to Dark)	1/25,000 second (0.04 ms)
Delay Control	Controls dark-to-light state from 0.1 to 0.9 seconds
Sensitivity Adjustment	Adjustable for ambient lighting (including sun light) and other welding arcs
Grinding Mode	Transforms helmet to grinding shield without shade flickering
Power ON/OFF	Fully Automatic
Shell Material	Nylon PA 66
Weight	20.6 ounces
Features	Ratcheting headband with padded sweatband, 3 arc sensors, Shade Control, Time Delay Control, Sensitivity Control.

TITANIUMTM

Shade Guide Chart

Guide for Shade Numbers				
Shade numbers are given as a guide only and may be varied to suit individual needs.				
PROCESS	ELECTRODE SIZE	ARC CURRENT (Amperes)	MINIMUM PROTECTIVE SHADE	SUGGESTED ^a SHADE NO. (Comfort)
Shielded Metal Arc Welding (SMAW)	Less than 3/32" (2.4 mm)	Less than 60	7	—
	3/32–5/32" (2.4–4.0 mm)	60–160	8	10
	5/32–1/4" (4.0–6.4 mm)	160–250	10	12
	More than 1/4" (6.4 mm)	250–550	11	14
Gas Metal Arc Welding (GMAW) and Flux-Cored Arc Welding (FCAW)		Less than 60	7	—
		60–160	10	11
		160–250	10	12
		250–550	10	14
Gas Tungsten Arc Welding (GTAW)		Less than 50	8	10
		50–150	8	12
		150–500	10	14
Air Carbon Arc Cutting (CAC-A)		LIGHT: Less than 500	10	12
		HEAVY: 500–1000	11	14
Plasma Arc Welding (PAW)		Less than 20	6	6 to 8
		20–100	8	10
		100–400	10	12
		400–800	11	14
Plasma Arc Cutting (PAC)		Less than 20	4	4
		20–40	5	5
		40–60	6	6
		60–80	8	8
		80–300	8	9
		300–400	9	12
		400–800	10	14
Torch Brazing (TB)		—	—	3 or 4
Torch Soldering (TS)		—	—	2
Carbon Arc Welding (CAW)		—	—	14
PLATE THICKNESS				
PROCESS	IN	MM	SUGGESTED SHADE NO. ^a (Comfort)	
Oxyfuel Gas Welding (OFW)	Light	Under 1/8"	Under 3 mm	4 or 5
	Medium	1/8 to 1/2"	3 to 13 mm	5 or 6
	Heavy	Over 1/2"	Over 13 mm	6 or 8
Oxygen Cutting (OC)	Light	Under 1"	Under 25 mm	3 or 4
	Medium	1 to 6"	25 to 150 mm	4 or 5
	Heavy	Over 6"	Over 150 mm	5 or 6

^a As a rule of thumb, start with a shade that is too dark to see the weld zone. Then go to a lighter shade which gives sufficient view of the weld zone without going below the minimum. In oxyfuel gas welding, cutting, or brazing where the torch and/or the flux produces a high yellow light, it is desirable to use a filter lens that absorbs the yellow or sodium line of the visible light spectrum.

Data from ANSI Z49.1:2012

SAFETY

SPECIFICATIONS

OPERATION

MAINTENANCE

Operating Instructions



Read the **ENTIRE IMPORTANT SAFETY INFORMATION** section at the beginning of this manual including all text under subheadings therein before set up or use of this product.

SAFETY

Function

The Auto-Darkening Welding Helmet is designed to protect the eyes and face from sparks, splatter, and harmful radiation under normal welding conditions. The Auto-Darkening Filter automatically changes from a clear state to a dark state when an arc is struck, and it returns to the clear state when welding stops.

Solar Cells

This Welding Helmet utilizes high performance solar cells as its power supply, and has a replaceable 3V CR2450 lithium battery as power backup. Refer to Maintenance section for battery replacement information.

SPECIFICATIONS

Shades

User-selectable variable shades from 5 to 9 and 9 to 13 are adjusted with the Set Switch, Set Switch, and Range Switch. This product is in full conformity with related DIN, ISO, EN379 safety standards and ANSI Z87.1-2020 standard.

Filters

The ultra high performance of UV and IR Auto-Darkening filters provides the user's eyes and face with full protection against UV and IR radiation during the entire welding process, even in clear state. The UV/IR protection level is up to shade 15 at all times.

Magnifying Cheater Lens

To attach a magnifying cheater lens (sold separately) to the inside of the helmet, slide the cheater lens into place underneath the tabs located on the lower right and left sides of the Lens Retaining Frame.

Before Welding

OPERATION

The Auto-Darkening Welding Helmet comes ready for use. Prior to first use, remove the protective film from both sides of the Front Lens Cover and Inside Lens Cover (if not already done). Check the Front Lens Cover to make sure that it is clean, and that no dirt is covering the four sensors on the front of the Auto Darkening Filter Cartridge. Also check the Inside Lens Cover and the Lens Retaining Frame, and make sure that they are secured in place.

Important: Make sure battery is properly installed before first use. Helmet is shipped with one CR2450 Lithium Battery.

Adjust the position of the headband, select the correct shade number for the welding application, and test the helmet for proper operation as described below.

Inspect all operating parts before each use for signs of wear or damage. Any scratched, cracked, or pitted parts should be replaced immediately before using again to avoid severe personal injury.

MAINTENANCE



Figure A: Helmet

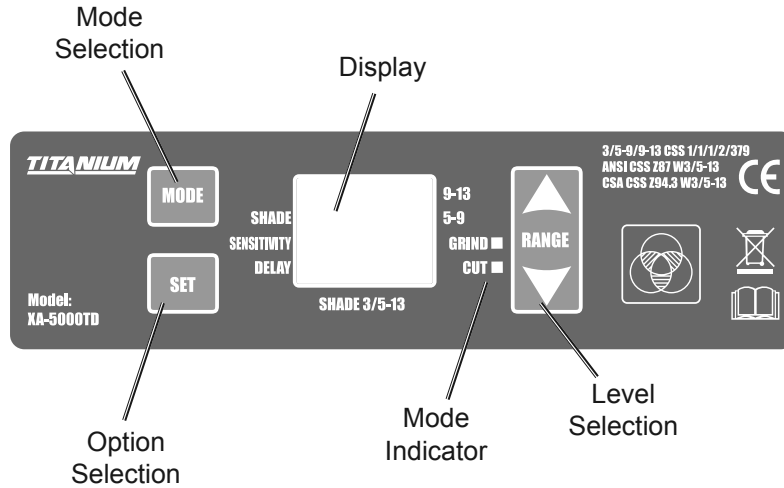

Figure B: Controls

Mode Selection and Shade Number

1. Use Set Switch to choose the Shade option.
2. Press Mode Switch to choose between Shade 5-9 or Shade 9-13. Selections will be shown on the display screen.
3. Using the Shade Guide Chart on page 5, select the shade range required using the Mode switch and then adjust the Shade Level upwards or downwards by using the Range switch.

Note: If a selection of shades are recommended for your application, try the darkest setting first.

4. To switch between Cut and Grind mode, press the Mode switch.

Note: To switch modes, you must not be in “Set” options.

5. The light next to “Grind” or “Cut” will indicate the mode after switching.

CAUTION! After using the Grind Mode set the Helmet to the proper shade setting before welding again.

6. The shade number can be set from 5 to 9 (cutting) or from 5 to 9 and 9 to 13 (welding) depending on the shade range selected.

Time Delay and Sensitivity

1. At the moment the welding operation is started, the filter screen automatically changes from clear to dark. The Delay function can vary the amount of time it takes the filter to return to a clear state after welding stops. Press Set Switch to select the Delay option.
2. Use the Range Switch to shorten or lengthen the delay time. The shortest delay time is 0.1 seconds (set to 1 using Range Switch). The longest delay time is 0.9 seconds (set to 5 using Range Switch).

3. The sensitivity setting changes the amount of light needed to make the filter react. Press the Set Switch to choose the Sensitivity option.
4. Use the Range switch to raise or lower the sensitivity (five stages of sensitivity are available). 1 indicates the lowest sensitivity, and 5 indicates the highest sensitivity.

Adjusting Headband

Adjust the Headband so that the Helmet is seated securely on your head as low as possible and close to your face using the following procedure:

1. Adjust Helmet Height by tightening or loosening the Top Straps until the Helmet fits snug on your head.
2. Adjust the Head Size by using the Head Size Adjustment Knob. Size should be adjusted so that the Front Lens Cover is aligned with your eyes and the Helmet fits firmly on your head.
3. Use the Segmental Positioning Mechanism to adjust the position of the Protection Plate for optimal viewing angles.

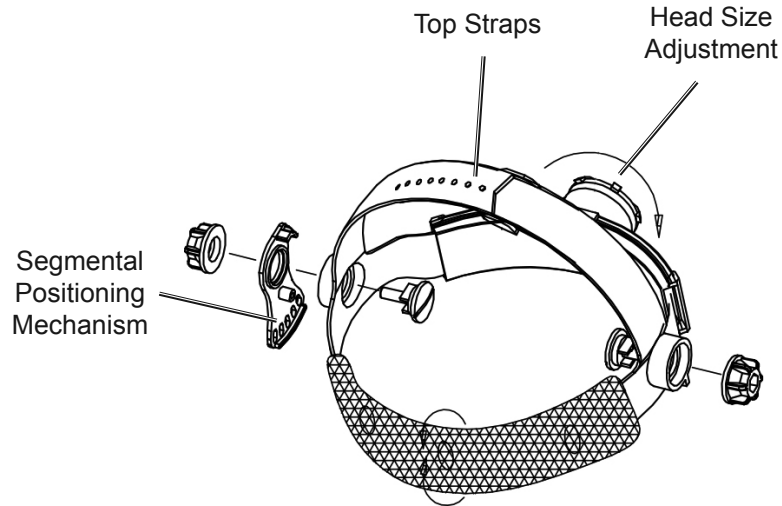

Figure C: Headgear Setup

TITANIUM™

⚠WARNING

TO PREVENT SERIOUS INJURY FROM TOOL FAILURE: Do not use damaged equipment. If damage or abnormal operation occurs, have the problem corrected before further use.

BEFORE EACH USE, inspect the general condition of the tool. Check for loose hardware, misalignment or binding of moving parts, cracked or broken parts, damaged electrical wiring, and any other condition that may affect its safe operation.

Note: Replace the Lens Cover(s) if they are cracked, scratched, soiled, pitted or damaged in any way. For additional information regarding the parts listed in the following pages, refer to *Parts List and Diagram* on page 11.

Outer Lens Replacement

1. Remove the Lens Frame from the Helmet Shell. Once the Lens Frame is removed, remove the Outer Lens from the Helmet Shell.
3. Install new Front Lens Cover into Gasket and assemble Lens, Gasket, and Lens Holder into Shell the same way they were removed.

2. Remove any protective film from both sides of the new Lens Cover.

NOTICE: Front lens must be in place during welding. Weld spatter will permanently damage Auto-Darkening Filter and voids warranty.

Inside Lens Cover Replacement

1. Remove the old Inside Lens Cover by pulling it up at the finger notch.
2. Remove any protective film from both sides of the new Lens Cover.
3. Line up the new Inside Lens Cover with the flanges at the sides of the lens and snap it into place.

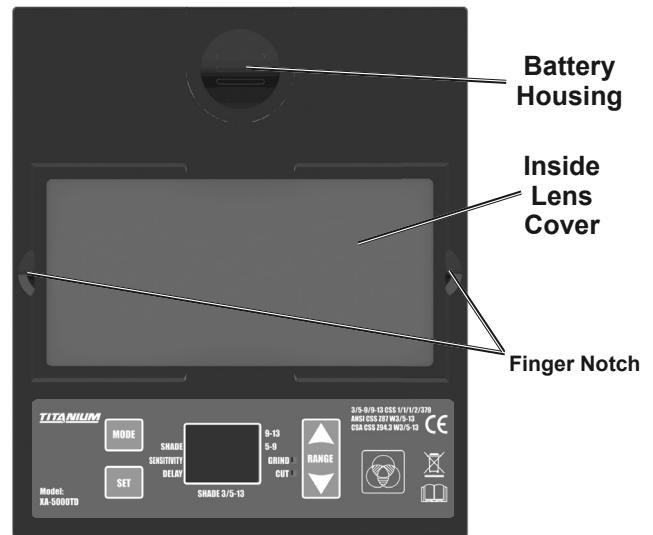

Figure D: Inside Lens Panel Setup

Filter Lens Replacement

1. Remove the Lens Frame from the Helmet Shell.
2. Remove the Auto-Darkening Filter from the Lens Frame.
3. Remove any protective film from both sides of the new Lens.
4. Install new Filter Lens into the Lens Holder and replace Lens Holder into Shell.

WARNING! TO PREVENT SERIOUS INJURY AND BLINDNESS:

Replace the filter lens **ONLY** with an exact replacement. Other lenses may not protect properly from welding light, or may not fit helmet closely enough to block all light at the edges.

Battery Installation or Replacement

There is a battery indicator in the top left corner of the Display Screen

To install Battery:

1. Remove the Automatic Filter from the Lens Holder.
2. Slide the Battery Housing out of the Auto-Darkening Filter. Remove the used battery (if applicable). See Figure D

Note: All used batteries must be properly disposed of.

3. Place a new CR2450 Lithium Battery inside the Battery Holder and put the Battery Holder back into the Auto-Darkening Filter. Make sure the new Battery is installed correctly.
4. Replace the Auto-Darkening Filter into the Lens Holder and replace Lens Holder into Shell.

Common Problems and Remedies

1. **Irregular Darkening Or Dimming**
 - a. Headband has been set unevenly on both sides of helmet (unequal distances from the eyes to filter's lens).
 - b. Reset Headband to reduce difference in distances to filter, if necessary.
2. **Auto-Darkening Filter Does Not Darken Or Flickers**
 - a. Front Lens Cover is soiled or damaged (change the cover).
 - b. Sensors are soiled (clean surface of the sensors).
 - c. Welding current is too low (adjust sensitivity).
3. **Slow Response**

Operating temperature is too low (do not use at temperatures below 14° F).
4. **Poor Vision**
 - a. Front/Inside Lens Cover and/or Filter soiled (change it).
 - b. Insufficient ambient light.
 - c. Shade number is incorrectly set (reset shade number).
5. **Welding Helmet Slips**

Headband is not adjusted properly (adjust to fit head snugly).

Stop using the Helmet immediately if any of these problems cannot be corrected.

PLEASE READ THE FOLLOWING CAREFULLY

THE MANUFACTURER AND/OR DISTRIBUTOR HAS PROVIDED THE PARTS DIAGRAM IN THIS MANUAL AS A REFERENCE TOOL ONLY. NEITHER THE MANUFACTURER NOR DISTRIBUTOR MAKES ANY REPRESENTATION OR WARRANTY OF ANY KIND TO THE BUYER THAT HE OR SHE IS QUALIFIED TO MAKE ANY REPAIRS TO THE PRODUCT OR THAT HE OR SHE IS QUALIFIED TO REPLACE ANY PARTS OF THE PRODUCT. IN FACT, THE MANUFACTURER AND/OR DISTRIBUTOR EXPRESSLY STATES THAT ALL REPAIRS AND PARTS REPLACEMENTS SHOULD BE UNDERTAKEN BY CERTIFIED AND LICENSED TECHNICIANS AND NOT BY THE BUYER. THE BUYER ASSUMES ALL RISK AND LIABILITY ARISING OUT OF HIS OR HER REPAIRS TO THE ORIGINAL PRODUCT OR REPLACEMENT PARTS THERETO, OR ARISING OUT OF HIS OR HER INSTALLATION OF REPLACEMENT PARTS THERETO.

Parts List and Assembly Diagram

Part	Description	Qty
1	Helmet Shell	1
2	Outer Protection Lens	1
3	Auto-Darkening Filter Frame	1
4	Auto-Darkening Filter	1
5	Inner Protection Lens	1
6	Headgear	1

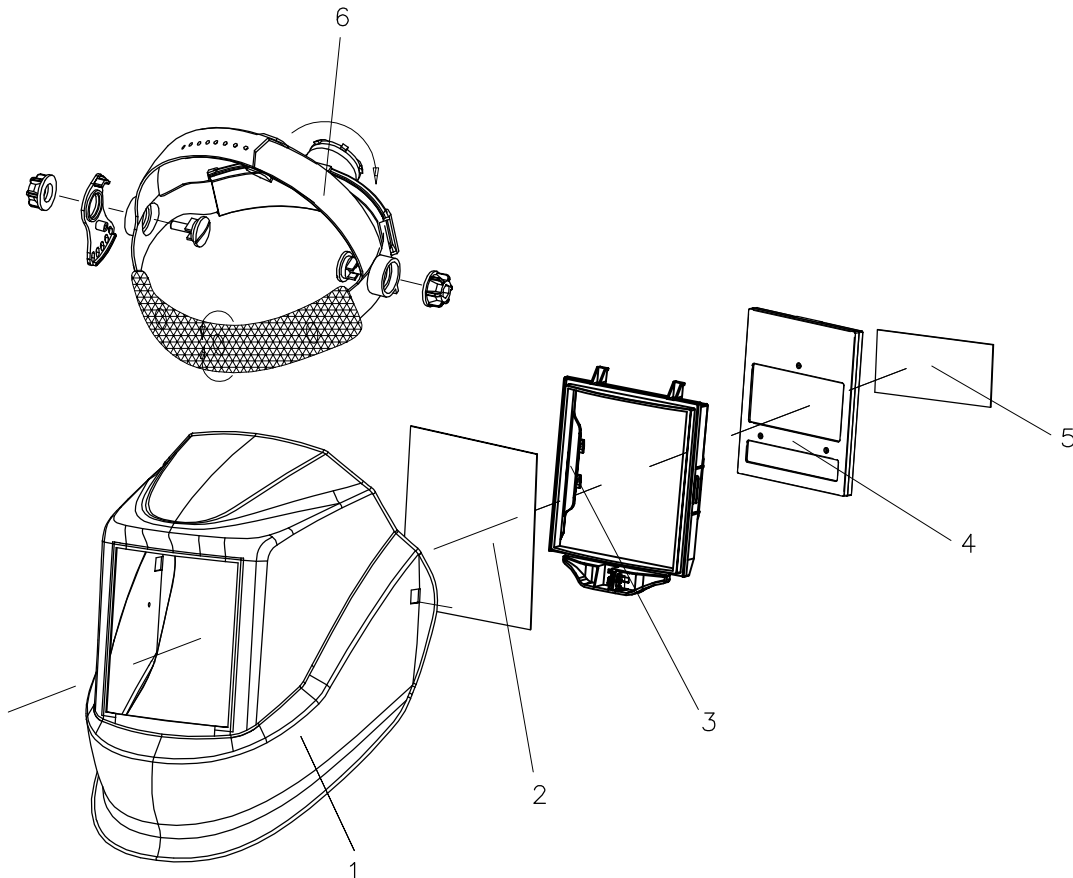

Record Product's Serial Number Here: _____

Note: If product has no serial number, record month and year of purchase instead.

Note: Some parts are listed and shown for illustration purposes only, and are not available individually as replacement parts. Specify UPC 193175431325 when ordering parts.

Limited 90 Day Warranty

Harbor Freight Tools Co. makes every effort to assure that its products meet high quality and durability standards, and warrants to the original purchaser that this product is free from defects in materials and workmanship for the period of 90 days from the date of purchase. This warranty does not apply to damage due directly or indirectly, to misuse, abuse, negligence or accidents, repairs or alterations outside our facilities, criminal activity, improper installation, normal wear and tear, or to lack of maintenance. We shall in no event be liable for death, injuries to persons or property, or for incidental, contingent, special or consequential damages arising from the use of our product. Some states do not allow the exclusion or limitation of incidental or consequential damages, so the above limitation of exclusion may not apply to you. THIS WARRANTY IS EXPRESSLY IN LIEU OF ALL OTHER WARRANTIES, EXPRESS OR IMPLIED, INCLUDING THE WARRANTIES OF MERCHANTABILITY AND FITNESS.

To take advantage of this warranty, the product or part must be returned to us with transportation charges prepaid. Proof of purchase date and an explanation of the complaint must accompany the merchandise. If our inspection verifies the defect, we will either repair or replace the product at our election or we may elect to refund the purchase price if we cannot readily and quickly provide you with a replacement. We will return repaired products at our expense, but if we determine there is no defect, or that the defect resulted from causes not within the scope of our warranty, then you must bear the cost of returning the product.

This warranty gives you specific legal rights and you may also have other rights which vary from state to state.

The logo for TITANIUM features the word "TITANIUM" in a bold, italicized, sans-serif font. The letters are black with a white outline. A thick black horizontal bar runs underneath the letters, starting from the left and ending under the "M". A small "TM" trademark symbol is located at the bottom right of the bar.

26541 Agoura Road • Calabasas, CA 91302 • 1-888-866-5797