

Owner's Manual & Safety Instructions

Save This Manual Keep this manual for the safety warnings and precautions, assembly, operating, inspection, maintenance and cleaning procedures. Write the product's serial number in the back of the manual near the assembly diagram (or month and year of purchase if product has no number). Keep this manual and the receipt in a safe and dry place for future reference.

24a

VULCAN™

ARC⚡SAFE™

AUTO DARKENING WELDING HELMET



58201

Visit our website at: <http://www.harborfreight.com>
Email our technical support at: productsupport@harborfreight.com

When unpacking, make sure that the product is intact and undamaged. If any parts are missing or broken, please call 1-888-866-5797 as soon as possible.

⚠️ WARNING

Read this material before using this product. Failure to do so can result in serious injury. **SAVE THIS MANUAL.**

Copyright© 2023 by Harbor Freight Tools®. All rights reserved.
No portion of this manual or any artwork contained herein may be reproduced in any shape or form without the express written consent of Harbor Freight Tools. Diagrams within this manual may not be drawn proportionally. Due to continuing improvements, actual product may differ slightly from the product described herein. Tools required for assembly and service may not be included.

Table of Contents

Safety	2	Maintenance and Servicing	9
Specifications	5	Parts List and Diagram	12
Operation	7	Warranty	15





SAFETY

SPECIFICATIONS

OPERATION

MAINTENANCE

WARNING SYMBOLS AND DEFINITIONS

	This is the safety alert symbol. It is used to alert you to potential personal injury hazards. Obey all safety messages that follow this symbol to avoid possible injury or death.
	Indicates a hazardous situation which, if not avoided, will result in death or serious injury.
	Indicates a hazardous situation which, if not avoided, could result in death or serious injury.
	Indicates a hazardous situation which, if not avoided, could result in minor or moderate injury.
	Addresses practices not related to personal injury.

IMPORTANT SAFETY INFORMATION

When using helmet, basic safety precautions should always be followed to reduce the risk of personal injury and damage to equipment.

The warnings, cautions, and instructions discussed in this instruction manual cannot cover all possible conditions and situations that may occur. It must be understood by the operator that common sense and caution are factors which cannot be built into this product, but must be supplied by the operator.

Read all instructions before using this helmet!

1. **Do not use the Welding Helmet if the lens is cracked, if the lens or sensors are dirty, or if the lens or front retaining frame is loose.**
2. **Keep work area clean.** Cluttered areas invite injuries.
3. **Observe work area conditions.** Do not use welding helmets in damp or wet locations. Do not expose to rain. Keep work area well lit. Do not use auto-darkening helmets in the presence of flammable gases or liquids.
4. **Keep children away.** Children must never be allowed in the work area. Do not let them handle this helmet. Dress properly. Do not wear loose clothing or jewelry. Keep your hair, clothing and gloves away from moving parts.
5. **Store idle equipment.** When not in use, helmets must be stored in a dry location to inhibit rust. Always lock up helmets and keep out of reach of children.
6. **Dress properly.** Do not wear loose clothing or jewelry as they can be caught in moving parts. Protective gear is essential to protect against welding rays, some examples are: a leather welding apron, welding sleeves, jeans without cuffs, work boots. Wear restrictive hair covering to contain long hair.
7. **Use breathing and hearing protection.** Wear a NIOSH-approved respirator and hearing protection when welding.
8. **Stay alert.** Watch what you are doing, use common sense. Do not weld when you are tired.
9. **Do not weld if under the influence of alcohol or drugs.** Read warning labels on prescriptions to determine if your judgment or reflexes are impaired while taking drugs. If there is any doubt, do not weld.

⚠️ WARNING



INHALATION HAZARD: Welding and Plasma Cutting Produce TOXIC FUMES.

Exposure to welding or cutting exhaust fumes can increase the risk of developing certain cancers, such as cancer of the larynx and lung cancer. Also, some diseases that may be linked to exposure to welding or plasma cutting exhaust fumes are:

- Early onset of Parkinson's Disease
- Heart disease
- Damage to the reproductive organs
- Inflammation of the small intestine or stomach
- Respiratory diseases such as emphysema, bronchitis, or pneumonia
- Ulcers
- Kidney damage

Use natural or forced air ventilation and wear a respirator approved by NIOSH to protect against the fumes produced to reduce the risk of developing the above illnesses.

10. **Check for damaged parts.** Before using any helmet, any part that appears damaged should be carefully checked to determine that it will operate properly and perform its intended function. Check for alignment and binding of moving parts; any broken parts or mounting fixtures; and any other condition that may affect proper operation. Any part that is damaged should be properly repaired or replaced by a qualified technician. Do not use the helmet if any switch does not operate properly.
11. **Replacement parts and accessories.** When servicing, use only identical replacement parts. Use of any other parts can render helmet ineffective, possibly causing eye damage, and will void the warranty. Only use accessories intended for use with this helmet. Approved accessories are available from Harbor Freight Tools.
12. **Maintenance.** For your safety, service and maintenance should be performed regularly only by a qualified technician.



SAVE THESE INSTRUCTIONS.

13. **This helmet provides protection for intended purposes only.** There are certain applications for which this helmet was designed. Do not modify this helmet and do not use this helmet for a purpose for which it was not intended:
 - a. **The Welding Helmet** is not suitable for laser welding.
 - b. **The Welding Helmet** will not protect against severe impact hazards.
 - c. **The Welding Helmet** will not protect against explosive devices or corrosive liquids.
14. **Use only at temperatures within the operating range for your model as stated on the specifications chart in this manual.**
15. Maintain the helmet and lens correctly to help ensure reliable protection:
 - a. Clean filter's surfaces regularly. Keep sensors and solar cells clean using a clean lint-free tissue/cloth. Do not use any solvents on filter's screen or helmet components. Protect filter from liquid and dirt contact. Do not immerse the filter in water.
 - b. Should the Auto-Darkening Welding Helmet not darken upon striking an arc, stop welding immediately and have the helmet checked by a qualified service technician.
 - c. Regularly replace the Front Lens Cover if it becomes cracked, scratched, pitted, or otherwise damaged.
 - d. Do not make any modifications to either the Auto-Darkening Filter or the rest of the helmet, other than those specified in this manual. Do not use any replacement parts other than those specified in this manual. Unauthorized modifications and replacement parts will void the warranty and expose the user to the risk of personal injury. Do not open or tamper with the Auto-Darkening Filter.
16. Do not place the Welding Helmet's Auto-Darkening Filter on a hot surface.
17. **SEVERE PERSONAL INJURY and/or BLINDNESS may occur if the user fails to follow the aforementioned warnings and/or fails to follow the operation instructions.**
18. Maintain labels and nameplates on the tool. These carry important safety information. If unreadable or missing, contact Harbor Freight Tools for a replacement.

Button/Coin Battery Warnings

SAFETY

SPECIFICATIONS

OPERATION

MAINTENANCE

⚠️ WARNING

- **INGESTION HAZARD:** This product contains a button cell or coin battery.
- **DEATH** or serious injury can occur if ingested.
- A swallowed button cell or coin battery can cause **Internal Chemical Burns** in as little as **2 hours**.
- **KEEP** new and used batteries **OUT OF REACH OF CHILDREN**
- **Seek immediate medical attention** if a battery is suspected to be swallowed or inserted inside any part of the body.



This symbol means:

INGESTION HAZARD: This product contains a button cell or coin battery.

1. Remove and immediately recycle or dispose of used batteries according to local regulations and keep away from children. Do NOT dispose of batteries in household trash or incinerate.
2. Even used batteries may cause severe injury or death.
3. Call a local poison control center for treatment information.
4. Non-rechargeable batteries are not to be recharged.
5. Do not force discharge, recharge, disassemble, heat above 158°F or incinerate. Doing so may result in injury due to venting, leakage or explosion resulting in chemical burns.
6. Ensure the batteries are installed correctly according to polarity (+ and -).
7. Do not mix old and new batteries, different brands or types of batteries, such as alkaline, carbon-zinc, or rechargeable batteries.
8. Remove and immediately recycle or dispose of batteries from equipment not used for an extended period of time according to local regulations.
9. Always completely secure the battery compartment. If the battery compartment does not close securely, stop using the product, remove the batteries, and keep them away from children.

Specifications

Description	Auto-Darkening Welding Helmet
Power Source	Solar powered cell with battery assistance (two replaceable 3V CR2450 lithium batteries)
Operating Temperature	14° to 131° F
Resting Shade	Shade #4
Shade Range	4/5-8/9-13 variable
UV/IR Protection	Up to DIN 16 at all times
Lens Type	ANSI Z87.1, CSA Z94.3 approved
Viewing Area	4.45" x 2.99" (13.30 sq. in.)
Welding Protection Types	Stick welding (SMAW); TIG DC&AC; TIG pulse DC; TIG pulse AC; MIG/MAG/C02; MIG/MAG pulse; Plasma arc cutting (PAC); Plasma arc welding (PAW); Air carbon arc cutting (CAC-A); Oxyfuel gas welding (OFW); Oxygen cutting (OC); Grinding. Not for Laser Welding.
Lens Switching Speed (Clear to Dark)	1/25,000 seconds
Delay Control	Controls dark-to-light state from 0.1 to 1.0 seconds
Sensitivity Adjustment	Adjustable for ambient lighting (including sun light) and other welding arcs
Grinding Mode	Transforms helmet to grinding shield without shade flickering
Power ON/OFF	Manual and Automatic
Shell Material	High Impact-Resistant Polyamide Nylon
Storage Temperature	-4° to 158° F
Weight	25 ounces
Features	Ratcheting headband with padded sweatband, 4 independent arc sensors.
Battery (Included)	CR2450, 3V battery x 2.

SAFETY

SPECIFICATIONS

OPERATION

MAINTENANCE

VULCAN™

Shade Guide Chart

SAFETY

SPECIFICATIONS

OPERATION

MAINTENANCE

Guide for Shade Numbers				
Shade numbers are given as a guide only and may be varied to suit individual needs.				
PROCESS	ELECTRODE SIZE	ARC CURRENT (Amperes)	MINIMUM PROTECTIVE SHADE	SUGGESTED ^a SHADE NO. (Comfort)
Shielded Metal Arc Welding (SMAW)	Less than 3" (2.5mm)	Less than 60	7	—
	3-5" (2.5-4.0mm)	60-160	8	10
	5-8" (4.0-6.4mm)	160-250	10	12
	More than 8" (6.4mm)	250-550	11	14
Gas Metal Arc Welding (GMAW) and Flux-Cored Arc Welding (FCAW)		Less than 60	7	—
		60-160	10	11
		160-250	10	12
		250-550	10	14
Gas Tungsten Arc Welding (GTAW)		Less than 50	8	10
		50-150	8	12
		150-500	10	14
Air Carbon Arc Cutting (CAC-A)		LIGHT: Less than 500	10	12
		HEAVY: 500-1000	11	14
Plasma Arc Welding (PAW)		Less than 20	6	6 to 8
		20-100	8	10
		100-400	10	12
		400-800	11	14
Plasma Arc Cutting (PAC)		LIGHT: Less than 300	8	8
		MEDIUM: 300-400	9	12
		HEAVY: 400-800	10	14
Torch Brazing (TB)		—	—	3 or 4
Torch Soldering (TS)		—	—	2
Carbon Arc Welding (CAW)		—	—	14
PLATE THICKNESS				
PROCESS	IN	MM	SUGGESTED SHADE NO. ^a (Comfort)	
Oxyfuel Gas Welding (OFW)	Light	Under 1/8"	Under 3mm	4 or 5
	Medium	1/8 to 1/2"	3 to 13mm	5 or 6
	Heavy	Over 1/2"	Over 13mm	6 or 8
Oxygen Cutting (OC)	Light	Under 1"	Under 25mm	3 or 4
	Medium	1 to 6"	25 to 150mm	4 or 5
	Heavy	Over 6"	Over 150mm	5 or 6

As a rule of thumb, start with a shade that is too dark to see the weld zone. Then go to a lighter shade which gives sufficient view of the weld zone without going below the minimum. In oxyfuel gas welding, cutting, or brazing where the torch and/or the flux produces a high yellow light, it is desirable to use a filter lens that absorbs the yellow or sodium line of the visible light spectrum.

Data from ANSI Z49.1:2012

Operating Instructions



Read the **ENTIRE IMPORTANT SAFETY INFORMATION** section at the beginning of this manual including all text under subheadings therein before set up or use of this product.

Function

The Auto-Darkening Welding Helmet is designed to protect the eyes and face from sparks, splatter, and harmful radiation under normal welding conditions. The Auto-Darkening Filter automatically changes from a clear state to a dark state when an arc is struck, and it returns to the clear state when welding stops.

Solar Cells

This Welding Helmet utilizes high performance solar cells as its power supply, and has two replaceable 3V CR2450 lithium batteries as power backup. Refer to Maintenance section for battery replacement information.

Shades

User-selectable variable shades from 5 to 8 and 9 to 13 are adjusted with the Shade Range and Shade Control on the Digital Screen (shade variable). This product is in full conformity with related DIN, ISO, EN379 safety standards and ANSI Z87.1-2015 standard.

Filters

The ultra high performance of UV and IR Auto-Darkening filters provides the user's eyes and face with full protection against UV and IR radiation during the entire welding process, even in clear state. The UV/IR protection level is up to shade 16 at all times.

Magnifying Cheater Lens

To attach a magnifying cheater lens (sold separately) to the inside of the helmet, slide the cheater lens into place underneath the tabs located on the lower right and left sides of the Lens Retaining Frame.

Before Welding

The Auto-Darkening Welding Helmet comes ready for use. Prior to first use, remove the protective film from both sides of the Front Lens Cover and Inside Lens Cover (if not already done). Check the Front Lens Cover to make sure that it is clean, and that no dirt is covering the four sensors on the front of the Auto Darkening Filter Cartridge. Also check the Inside Lens Cover and the Lens Retaining Frame, and make sure that they are secured in place.

Important: Helmet is shipped without Batteries installed. Before first use install two CR2450 Lithium Batteries included with the Helmet. Refer to Battery Installation or Replacement on page 11 for instructions.

Adjust the position of the headband, select the correct shade number for the welding application, and test the helmet for proper operation as described below.

Inspect all operating parts before each use for signs of wear or damage. Any scratched, cracked, or pitted parts should be replaced immediately before using again to avoid severe personal injury.

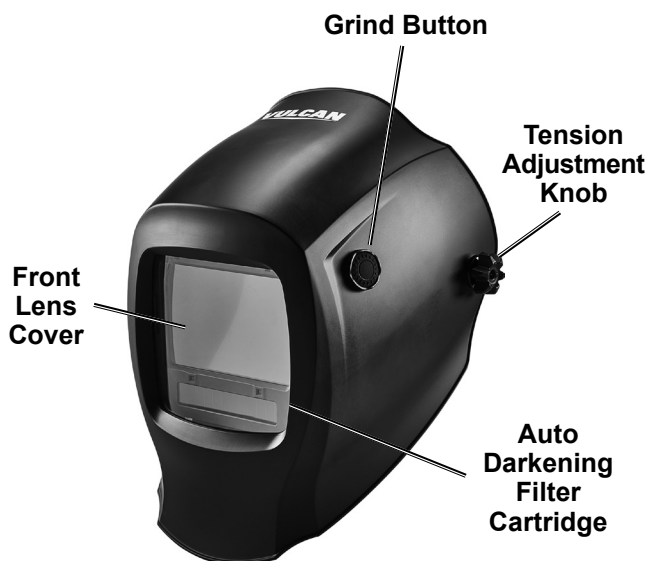

Controls

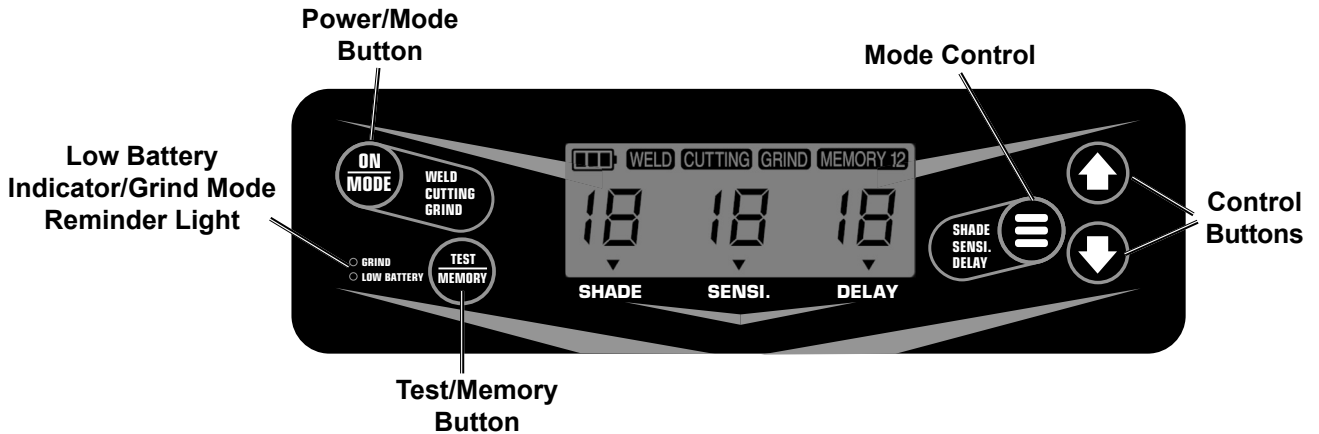

Mode Selection and Shade Number

1. Use the Mode Control Button to select the mode of operation. Make sure the correct mode is selected for your application.
 - Set to Weld Mode for welding applications. In this mode the Auto-Darkening Filter automatically changes from a clear state to a dark state when an arc is struck. Select shade level, time delay and sensitivity as required.
 - Set to Grind Mode for grinding applications. This turns off the shade function so the helmet lens stays clear. Use this function to provide protection while grinding. The green light indicator will flash every three seconds to signal helmet is in Grind Mode.
 - Set to Cutting Mode for plasma or oxygen acetylene cutting applications. In this mode Auto-Darkening Filter automatically changes from a clear state to a dark state when cutting arc is initiated. Select shade level, time delay and sensitivity as required.

CAUTION! After using the Grind Mode set the Helmet to the proper shade setting before welding again.

2. Using the Shade Guide Chart on page 6, select the shade range required by selecting Shade Range using Mode Control Button, then press the Control Buttons to the shade number required.

Note: If a selection of shades are recommended for your application, try the darkest setting first.

3. The shade number can be set from 5 to 8 (cutting) or from 9 to 13 (welding) depending on the shade range selected. Press the Control Buttons until desired Shade Number selected. Be sure that the shade number of the Welding Helmet is the correct shade number for your application.

4. Remember to check with the Shade Guide Chart on page 6 to determine the proper shade number for your application.

Important: Test the helmet auto-darkening filter lens before welding. Press TEST/MEMORY button to preview selected shade number. When button is released the lens will return to resting state (#4 Shade). If lens does not darken properly, replace Batteries and try again. Do not use Welding Helmet if it is not operating correctly.



Memory

1. Memory can store two records. Press TEST/MEMORY button. The factory memory settings will be shown under MEMORY 1. MEMORY 1 icon is displayed at the top-right corner.
2. If factory settings require modification, short press MODE CONTROL button. The "▼" below the numbers will move left and right switching between SHADE/SENSI/DELAY modes.
3. Short press CONTROL BUTTONS to adjust the value of selected mode "SHADE/SENSI/DELAY". The adjustments will be automatically saved and will replace the factory settings.
4. If MEMORY 2 settings require modification, press TEST/MEMORY button. MEMORY 2 icon will now be displayed at top-right corner.

Time Delay and Sensitivity

1. At the moment the welding operation is started, the filter screen automatically changes from clear to dark. The operator can vary the amount of time it takes the filter to return to a clear state after welding stops by adjusting Time Delay on the Digital Screen.
2. Press Mode Control Button until Time Delay is selected. Use the Control Buttons to delay time between 0 ("S" short) and 10 ("L" long).
3. The sensitivity setting changes the amount of light needed to make the filter react. To adjust sensitivity press Mode Control Button until Sensitivity is selected. Use The Control Buttons to adjust sensitivity of the sensors.
4. Use the Control Buttons while Sensitivity is selected to set the sensitivity between 0 (Low sensitivity) and 10 (High sensitivity).

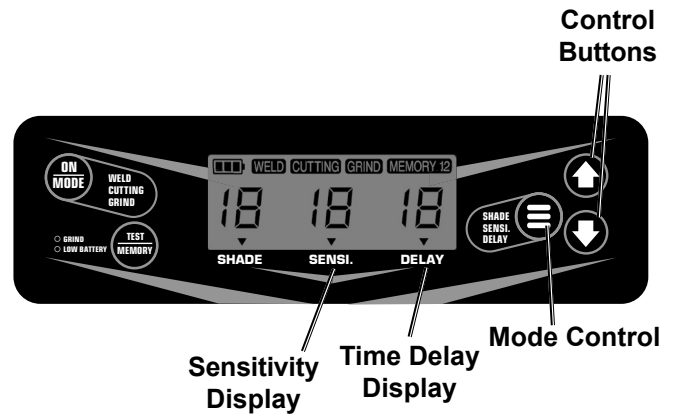

Adjusting Headband

Adjust the Headband so that the Helmet is seated securely on your head as low as possible and close to your face using the following procedure:

- a. Adjust the Headband width by turning the Headband Adjustment Knob while wearing the Helmet to make sure the Front Lens Cover is aligned with your eyes and the Helmet fits firmly on the head.
- b. Adjust the Headband height by tightening or loosening the Top Straps until the Helmet fits snug on your head.
- c. Adjust the distance between the front of the Helmet and your face by loosening the Tension Adjustment Knobs and sliding the Headband harness forward or back.
- d. To adjust the tilt angle, loosen the right Tension Adjustment Knob and push the top of the Angle Adjustment Lever outward until the Lever's stop tab clears the notches. Rotate the Lever forward or back to the desired position, then release the Lever to engage the stop tab.
- e. Once the Headband is properly adjusted, lower the Helmet over your face until the proper angle is found. Then turn the Tension Adjustment Knobs on either side of the helmet, locking the helmet's angle in place.

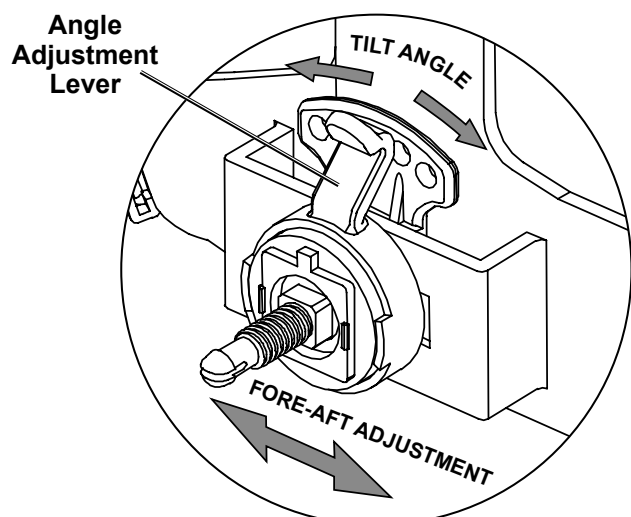
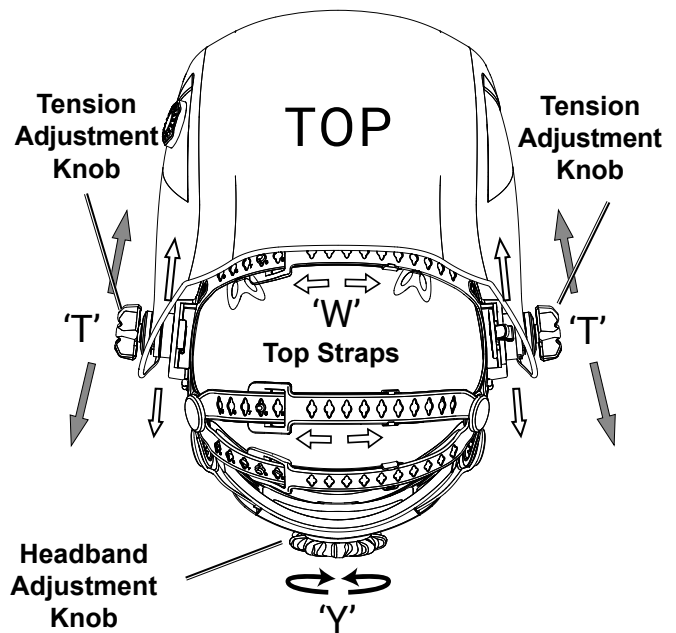

⚠ WARNING

TO PREVENT SERIOUS INJURY FROM TOOL FAILURE: Do not use damaged equipment. If damage or abnormal operation occurs, have the problem corrected before further use.

BEFORE EACH USE, inspect the general condition of the tool. Check for loose hardware, misalignment or binding of moving parts, cracked or broken parts, damaged electrical wiring, and any other condition that may affect its safe operation.

Note: Replace the Lens Cover(s) if they are cracked, scratched, soiled, pitted or damaged in any way. For additional information regarding the parts listed in the following pages, refer to *Parts List and Diagram* on page 12.

Front Cover Lens Replacement

1. Unlock Lens Holder Lock to remove Lens Holder (E). Lift up to remove/replace Front Cover Lens (B).
2. Remove Front Cover Lens from Shell (A). Refer to *Parts List and Diagram* on page 12.

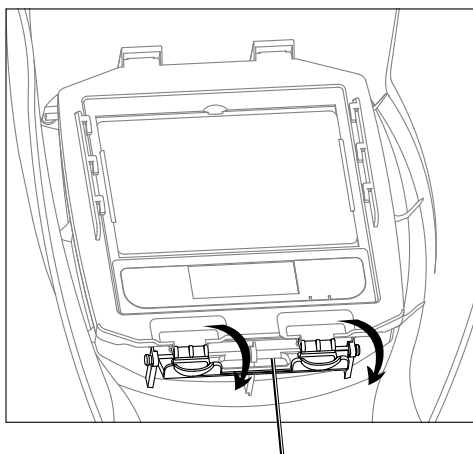

Lens Holder (E)

3. If replacing Front Cover Lens remove any protective film from both sides of new Front Cover Lens.
4. Install new Front Cover Lens into Shell the same way it was removed.

NOTICE: Front Cover Lens must be in place during welding. Weld spatter will permanently damage Auto Darkening Filter and voids warranty.

Inside Cover Lens Replacement

1. Replace Inside Cover Lens (D) if damaged. Place fingernail in recess below view window and flex Inside Cover Lens upwards until releases from edges of view window.
2. If replacing Inside Cover Lens remove any protective film from both sides of new Inside Cover Lens.
3. Line up the new Inside Cover Lens with the flanges at the sides of the lens and snap it into place.

Filter Lens Replacement

1. Unplug wire from grind control case. Unlock Lens Holder Lock. Remove Auto Darkening Filter (C).

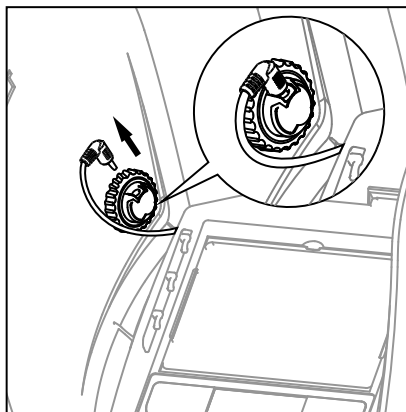

WARNING! TO PREVENT SERIOUS INJURY AND BLINDNESS:

Replace the filter lens **ONLY** with an exact replacement. Other lenses may not protect properly from welding light, or may not fit helmet closely enough to block all light at the edges.

2. Flex top end of Lens Holder to remove Auto Darkening Filter.
3. Remove any protective film from both sides of the new Lens.

4. Install new Filter Lens into the Lens Holder and install Lens Holder assembly into Shell.
5. Plug Auto Darkening Filter wire into grind control case.

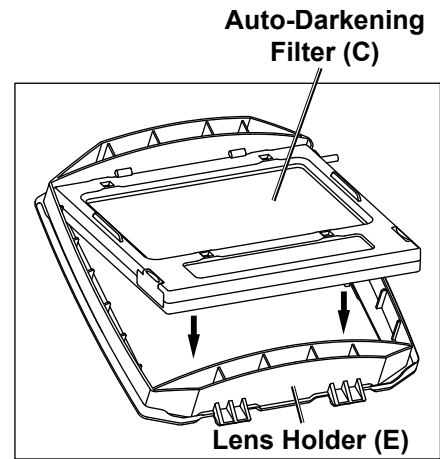

Battery Installation or Replacement

To install Batteries before first use or when the LOW BATTERY LED begins to turn red, indicating Batteries need replaced:

- a. Remove the Auto Darkening Filter (C) from the Lens Holder (E) as described in *Filter Lens Replacement*.
- b. Slide both Battery Holders out of the Auto Darkening Filter. Remove the used batteries (if applicable).
- c. Place two new CR2450 Lithium Batteries inside the Battery Holders and put the Battery Holders back into the Auto Darkening Filter. Make sure the new Batteries are installed correctly.
- d. Replace the Auto Darkening Filter into the Lens Holder and install Lens Holder into Shell.

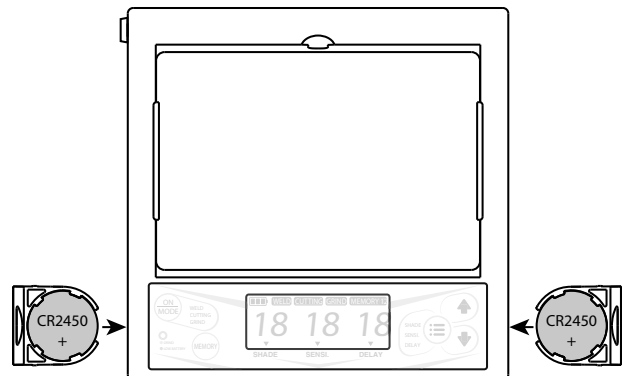

Common Problems and Remedies

1. **Irregular Darkening Or Dimming**
 - a. Headband has been set unevenly on both sides of helmet (unequal distances from the eyes to filter's lens).
 - b. Reset Headband to reduce difference in distances to filter, if necessary.
2. **Auto-Darkening Filter Does Not Darken Or Flickers**
 - a. Front Lens Cover is soiled or damaged (change the cover).
 - b. Sensors are soiled (clean surface of the sensors).
 - c. Welding current is too low (turn Sensitivity Adjustment Knob to the "HI" position, if necessary).
 - d. Check batteries and verify they are in good condition and installed properly. Also, check battery surfaces and contacts and clean if necessary.
 - e. Make sure "POWER/MODE" button has been pushed, the user can monitor the settings from the display panel.
3. **Slow Response**
Operating temperature is too low (do not use at temperatures below 14° F).
4. **Poor Vision**
 - a. Front/Inside Lens Cover and/or Filter soiled (change it).
 - b. Insufficient ambient light.
 - c. Shade number is incorrectly set (reset shade number).
5. **Welding Helmet Slips**
Headband is not adjusted properly (must be lowered).

Stop using the Helmet immediately if any of these problems cannot be corrected.

PLEASE READ THE FOLLOWING CAREFULLY

THE MANUFACTURER AND/OR DISTRIBUTOR HAS PROVIDED THE PARTS DIAGRAM IN THIS MANUAL AS A REFERENCE TOOL ONLY. NEITHER THE MANUFACTURER NOR DISTRIBUTOR MAKES ANY REPRESENTATION OR WARRANTY OF ANY KIND TO THE BUYER THAT HE OR SHE IS QUALIFIED TO MAKE ANY REPAIRS TO THE PRODUCT OR THAT HE OR SHE IS QUALIFIED TO REPLACE ANY PARTS OF THE PRODUCT. IN FACT, THE MANUFACTURER AND/OR DISTRIBUTOR EXPRESSLY STATES THAT ALL REPAIRS AND PARTS REPLACEMENTS SHOULD BE UNDERTAKEN BY CERTIFIED AND LICENSED TECHNICIANS AND NOT BY THE BUYER. THE BUYER ASSUMES ALL RISK AND LIABILITY ARISING OUT OF HIS OR HER REPAIRS TO THE ORIGINAL PRODUCT OR REPLACEMENT PARTS THERETO, OR ARISING OUT OF HIS OR HER INSTALLATION OF REPLACEMENT PARTS THERETO.

Parts List

Part	Description	Qty
A	Shell (Welding mask)	1
B	Front Cover Lens	1
C	Auto Darkening Filter (Including 2xCR2450 lithium battery)	1
D	Inside Cover Lens	1
E	Lens Holder	1
F	Headgear Assembly (Including Sweatband)	1
1	Sweatband	1
2	Washer	1
3	Washer	1
4	Fixed Washer	2
5	Rubber Washer	2
6	Block Nut	2
7	Gear Washer	1
8	Angle Limitation Washer	1
9	Right Boot Screw	1
10	Left Boot Screw	1
11	Adjustable Headband	1
12	Front Headgear	1
13	Butterfly	2

SAFETY

SPECIFICATIONS

OPERATION

MAINTENANCE

Assembly Diagram

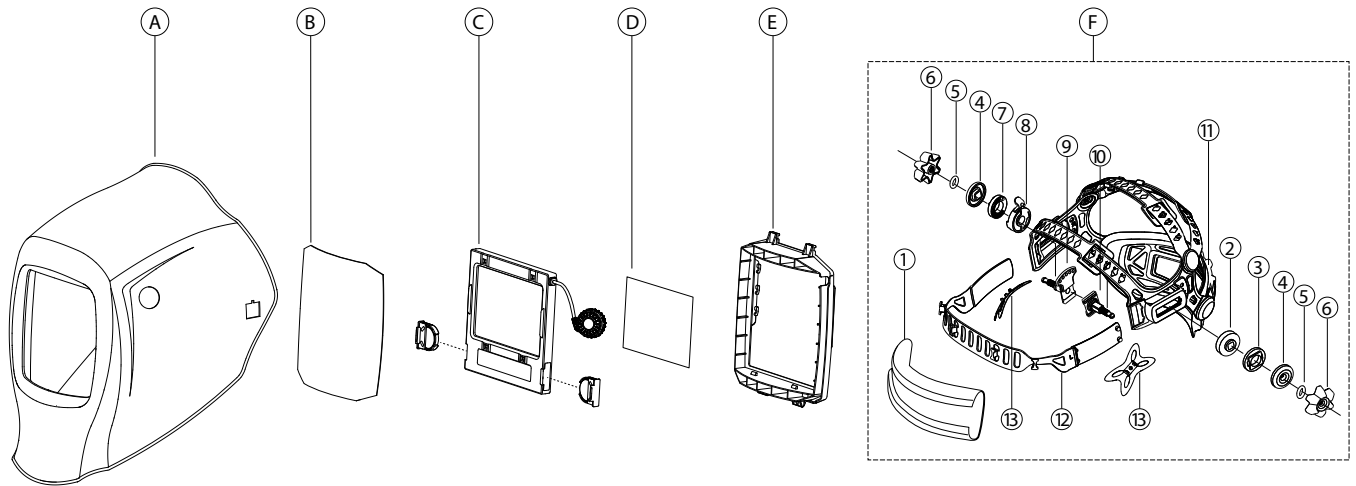

SAFETY

SPECIFICATIONS

OPERATION

MAINTENANCE

Record Product's Serial Number Here: _____

Note: If product has no serial number, record month and year of purchase instead.

Note: Some parts are listed and shown for illustration purposes only, and are not available individually as replacement parts. Specify UPC 193175508591 when ordering parts.

SAFETY

SPECIFICATIONS

OPERATION

MAINTENANCE

Limited 90 Day Warranty

Harbor Freight Tools Co. makes every effort to assure that its products meet high quality and durability standards, and warrants to the original purchaser that this product is free from defects in materials and workmanship for the period of 90 days from the date of purchase. This warranty does not apply to damage due directly or indirectly, to misuse, abuse, negligence or accidents, repairs or alterations outside our facilities, criminal activity, improper installation, normal wear and tear, or to lack of maintenance. We shall in no event be liable for death, injuries to persons or property, or for incidental, contingent, special or consequential damages arising from the use of our product. Some states do not allow the exclusion or limitation of incidental or consequential damages, so the above limitation of exclusion may not apply to you. THIS WARRANTY IS EXPRESSLY IN LIEU OF ALL OTHER WARRANTIES, EXPRESS OR IMPLIED, INCLUDING THE WARRANTIES OF MERCHANTABILITY AND FITNESS.

To take advantage of this warranty, the product or part must be returned to us with transportation charges prepaid. Proof of purchase date and an explanation of the complaint must accompany the merchandise. If our inspection verifies the defect, we will either repair or replace the product at our election or we may elect to refund the purchase price if we cannot readily and quickly provide you with a replacement. We will return repaired products at our expense, but if we determine there is no defect, or that the defect resulted from causes not within the scope of our warranty, then you must bear the cost of returning the product.

This warranty gives you specific legal rights and you may also have other rights which vary from state to state.

SAFETY

SPECIFICATIONS

OPERATION

MAINTENANCE

VULCANTM

The logo features the word "VULCAN" in a bold, black, sans-serif font. Below the text is a thick, black, downward-pointing chevron shape that tapers at both ends, creating a stylized underline for the brand name.

26677 Agoura Road • Calabasas, CA 91302 • 1-888-866-5797