

Owner's Manual & Safety Instructions

Save This Manual Keep this manual for the safety warnings and precautions, assembly, operating, inspection, maintenance and cleaning procedures. Write the product's serial number in the back of the manual near the assembly diagram (or month and year of purchase if product has no number). Keep this manual and the receipt in a safe and dry place for future reference.

21c

PITTSBURGH[®]

58231

12" Digital Caliper



Visit our website at: <http://www.harborfreight.com>
Email our technical support at: productsupport@harborfreight.com

When unpacking, make sure that the product is intact and undamaged. If any parts are missing or broken, please call 1-888-866-5797 as soon as possible.

⚠ WARNING

Copyright © 2021 by Harbor Freight Tools[®]. All rights reserved. No portion of this manual or any artwork contained herein may be reproduced in any shape or form without the express written consent of Harbor Freight Tools. Diagrams within this manual may not be drawn proportionally. Due to continuing improvements, actual product may differ slightly from the product described herein. Tools required for assembly and service may not be included.

Read this material before using this product. Failure to do so can result in serious injury. **SAVE THIS MANUAL.**

Specifications

Display Units	Inches & Millimeters
Accuracy	$\pm 0.001"$ (0.08mm)
Display	0.0005" (0.01mm)
Power Supply	1.5V LR44 (Included)

Important Safety Information

- CONTAINS BUTTON BATTERY.**
Keep out of your child's reach.
Discard button batteries carefully.
Do not allow children to play with devices that contain button batteries.
This product is not a toy.
- Wear ANSI-approved safety goggles during use.
- Keep work area clean and well lit.
- Do not operate when tired or when under the influence of alcohol, drugs or medication.
- Use as intended only.
- Inspect before every use; do not use if parts are loose or damaged.
- Maintain product labels and nameplates. These carry important safety information. If unreadable or missing, contact Harbor Freight Tools for a replacement.

Components and Controls

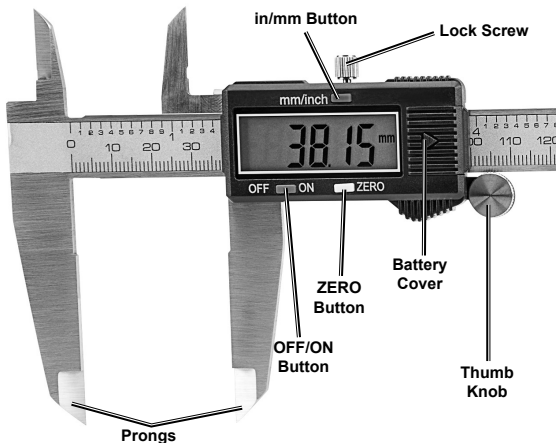

Instructions

1. Push the OFF ON button to turn caliper on.
 2. To toggle measurement between inches and millimeters, press in/mm button.
 3. With jaws closed, press ZERO to set readout to 0.
 4. To measure outside of object, set the bottom prongs outside object being measured. Slide the jaws together until they gently contact the item.
 5. To measure inside of object, set the top prongs inside object being measured. Spread prongs apart until they touch surface of object.
 6. Press OFF ON button to turn Caliper off. Caliper also has an automatic OFF function.
- Note:** Replacement parts are not available.



Outside Measurement



Inside Measurement

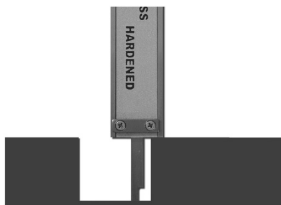

Depth Measurement



Step Measurement

Maintenance and Servicing



Procedures not specifically explained in this manual must be performed only by a qualified technician.

Cleaning and Maintenance

1. Keep body face clean. Prevent liquid from getting into slider.
2. Face should be cleaned with a clean, dry, lint-free cloth.
3. Lubricate body with a few drops of clock oil.
4. Keep battery compartment clean and free of corrosion.

Note: Do not clean with acetone or alcohol.

Battery Removal and Replacement

1. Open battery compartment to right of display.
2. Remove battery.
3. Install new SR44 battery positive (flat) side up, and slide Battery Cover back into place.
4. Keep batteries out of reach of children. Keep batteries in original package until ready to use. Discard used batteries immediately. Do not allow children to play with devices containing batteries.

Troubleshooting

Problem	Possible Causes	Possible Solutions
Every second 5 digits jump simultaneously.	Low Battery.	Replace Battery.
Display cannot count.	Faulty Circuit.	Remove Battery, wait 30 seconds, and replace Battery.
Display shows 000.00 or IN 00.000	Function button springs misaligned.	Have qualified technician service Caliper.
Reading error for full length is ≥ 0.1 mm	Sensor may be obstructed.	Have qualified technician service Caliper.
No display on LCD screen.	<ol style="list-style-type: none">1. Poor battery contact.2. Low Battery.	<ol style="list-style-type: none">1. Remove Battery from Compartment. Clean Battery Compartment and replace Battery.2. Replace Battery.
 <p>Follow all safety precautions whenever diagnosing or servicing the tool. Remove battery before service.</p>		

Parts List and Diagram

PLEASE READ THE FOLLOWING CAREFULLY

THE MANUFACTURER AND/OR DISTRIBUTOR HAS PROVIDED THE PARTS DIAGRAM IN THIS MANUAL AS A REFERENCE TOOL ONLY. NEITHER THE MANUFACTURER NOR DISTRIBUTOR MAKES ANY REPRESENTATION OR WARRANTY OF ANY KIND TO THE BUYER THAT HE OR SHE IS QUALIFIED TO MAKE ANY REPAIRS TO THE PRODUCT OR THAT HE OR SHE IS QUALIFIED TO REPLACE ANY PARTS OF THE PRODUCT. IN FACT, THE MANUFACTURER AND/OR DISTRIBUTOR EXPRESSLY STATES THAT ALL REPAIRS AND PARTS REPLACEMENTS SHOULD BE UNDERTAKEN BY CERTIFIED AND LICENSED TECHNICIANS AND NOT BY THE BUYER. THE BUYER ASSUMES ALL RISK AND LIABILITY ARISING OUT OF HIS OR HER REPAIRS TO THE ORIGINAL PRODUCT OR REPLACEMENT PARTS THERETO, OR ARISING OUT OF HIS OR HER INSTALLATION OF REPLACEMENT PARTS THERETO.

Parts List

Part	Description	Qty.
1	Beam	1
2	Slide	1
3	LCD Display	1
4	Depth Measure	1
5	Down Baffled	1
6	Screw	2
7	Top Baffled	1
8	Back Label	1
9	Underlay	2
10	Sensor Plant	1
11	Scale	1
12	Reed	1
13	Screw	1
14	Pin	2
15	Roller Wheel	1
16	Screw	5

Record Product's Serial Number Here: _____

Note: If product has no serial number, record month and year of purchase instead.

Note: Some parts are listed and shown for illustration purposes only, and are not available individually as replacement parts. Specify UPC 193175434470 when ordering parts.

Assembly Diagram

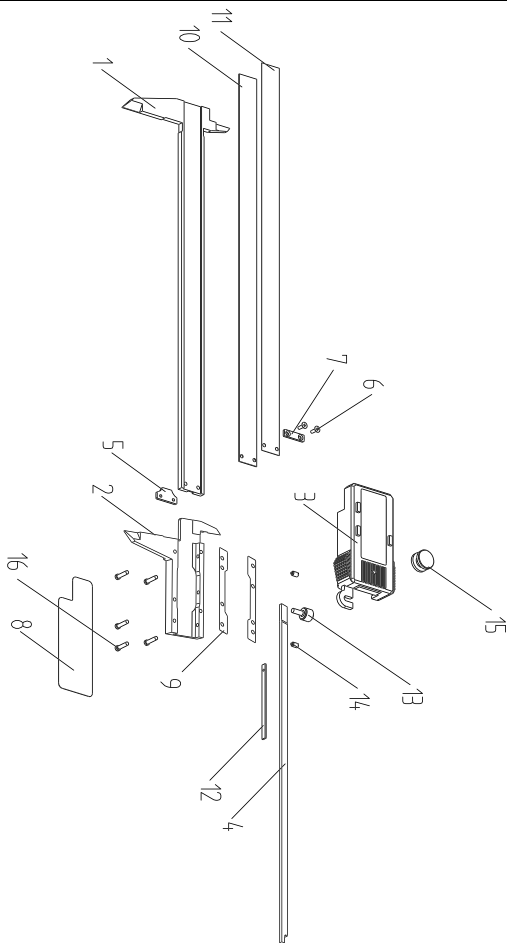

Limited 90 Day Warranty

Harbor Freight Tools Co. makes every effort to assure that its products meet high quality and durability standards, and warrants to the original purchaser that this product is free from defects in materials and workmanship for the period of 90 days from the date of purchase. This warranty does not apply to damage due directly or indirectly, to misuse, abuse, negligence or accidents, repairs or alterations outside our facilities, criminal activity, improper installation, normal wear and tear, or to lack of maintenance. We shall in no event be liable for death, injuries to persons or property, or for incidental, contingent, special or consequential damages arising from the use of our product. Some states do not allow the exclusion or limitation of incidental or consequential damages, so the above limitation of exclusion may not apply to you. THIS WARRANTY IS EXPRESSLY IN LIEU OF ALL OTHER WARRANTIES, EXPRESS OR IMPLIED, INCLUDING THE WARRANTIES OF MERCHANTABILITY AND FITNESS.

To take advantage of this warranty, the product or part must be returned to us with transportation charges prepaid. Proof of purchase date and an explanation of the complaint must accompany the merchandise. If our inspection verifies the defect, we will either repair or replace the product at our election or we may elect to refund the purchase price if we cannot readily and quickly provide you with a replacement. We will return repaired products at our expense, but if we determine there is no defect, or that the defect resulted from causes not within the scope of our warranty, then you must bear the cost of returning the product.

This warranty gives you specific legal rights and you may also have other rights which vary from state to state.

PITTSBURGH