

Owner's Manual & Safety Instructions

Save This Manual Keep this manual for the safety warnings and precautions, assembly, operating, inspection, maintenance and cleaning procedures. Write the product's serial number in the back of the manual (or month and year of purchase if product has no number). Keep this manual and the receipt in a safe and dry place for future reference.

22f

Bauer™

21703CR-B

BRUSHLESS

20V

HYPERMAX™ LITHIUM



For Maximum Performance,
Use 3.0 Amp Hour Battery or Greater
(Sold Separately)

5-3/8" METAL CUTTING CIRCULAR SAW

Battery, Charger and Blade sold separately

Visit our website at: <http://www.harborfreight.com>
Email our technical support at: productsupport@harborfreight.com

58261

When unpacking, make sure that the product is intact and undamaged. If any parts are missing or broken, please call 1-888-866-5797 as soon as possible.

⚠️ WARNING

Read this material before using this product. Failure to do so can result in serious injury. **SAVE THIS MANUAL.**

Copyright© 2021 by Harbor Freight Tools®. All rights reserved.
No portion of this manual or any artwork contained herein may be reproduced in any shape or form without the express written consent of Harbor Freight Tools. Diagrams within this manual may not be drawn proportionally. Due to continuing improvements, actual product may differ slightly from the product described herein. Tools required for assembly and service may not be included.

Table of Contents

Safety	2	Maintenance	12
Specifications	8	Parts List and Diagram	14
Setup	8	Warranty	16
Operation	10		

SAFETY



SETUP

OPERATION

MAINTENANCE

WARNING SYMBOLS AND DEFINITIONS	
	This is the safety alert symbol. It is used to alert you to potential personal injury hazards. Obey all safety messages that follow this symbol to avoid possible injury or death.
	Indicates a hazardous situation which, if not avoided, will result in death or serious injury.
	Indicates a hazardous situation which, if not avoided, could result in death or serious injury.
	Indicates a hazardous situation which, if not avoided, could result in minor or moderate injury.
	Addresses practices not related to personal injury.

IMPORTANT SAFETY INFORMATION

General Power Tool Safety Warnings

WARNING

Read all safety warnings, instructions, illustrations and specifications provided with this power tool. Failure to follow all instructions listed below may result in electric shock, fire and/or serious injury.

Save all warnings and instructions for future reference.

The term "power tool" in the warnings refers to your mains-operated (corded) power tool or battery-operated (cordless) power tool.

1. **Work area safety**
 - a. **Keep work area clean and well lit.**
Cluttered or dark areas invite accidents.
 - b. **Do not operate power tools in explosive atmospheres, such as in the presence of flammable liquids, gases or dust.** *Power tools create sparks which may ignite the dust or fumes.*
 - c. **Keep children and bystanders away while operating a power tool.** *Distractions can cause you to lose control.*

2. Electrical safety

- a. **Power tool plugs must match the outlet. Never modify the plug in any way. Do not use any adapter plugs with earthed (grounded) power tools.** *Unmodified plugs and matching outlets will reduce risk of electric shock.*
- b. **Avoid body contact with earthed or grounded surfaces, such as pipes, radiators, ranges and refrigerators.** *There is an increased risk of electric shock if your body is earthed or grounded.*
- c. **Do not expose power tools to rain or wet conditions.** *Water entering a power tool will increase the risk of electric shock.*
- d. **Do not abuse the cord. Never use the cord for carrying, pulling or unplugging the power tool. Keep cord away from heat, oil, sharp edges or moving parts.** *Damaged or entangled cords increase the risk of electric shock.*
- e. **When operating a power tool outdoors, use an extension cord suitable for outdoor use.** *Use of a cord suitable for outdoor use reduces the risk of electric shock.*
- f. **If operating a power tool in a damp location is unavoidable, use a ground fault circuit interrupter (GFCI) protected supply.** *Use of a GFCI reduces the risk of electric shock.*

3. Personal safety

- a. **Stay alert, watch what you are doing and use common sense when operating a power tool. Do not use a power tool while you are tired or under the influence of drugs, alcohol or medication.** *A moment of inattention while operating power tools may result in serious personal injury.*
- b. **Use personal protective equipment. Always wear eye protection.** *Protective equipment such as dust mask, non-skid safety shoes, hard hat, or hearing protection used for appropriate conditions will reduce personal injuries.*
- c. **Prevent unintentional starting. Ensure the switch is in the off-position before connecting to power source and/or battery pack, picking up or carrying the tool.** *Carrying power tools with your finger on the switch or energizing power tools that have the switch on invites accidents.*
- d. **Remove any adjusting key or wrench before turning the power tool on.** *A wrench or a key left attached to a rotating part of the power tool may result in personal injury.*
- e. **Do not overreach. Keep proper footing and balance at all times.** *This enables better control of the power tool in unexpected situations.*

- f. **Dress properly. Do not wear loose clothing or jewelry. Keep your hair, clothing and gloves away from moving parts.** *Loose clothes, jewelry or long hair can be caught in moving parts.*
- g. **If devices are provided for the connection of dust extraction and collection facilities, ensure these are connected and properly used.** *Use of dust collection can reduce dust-related hazards.*
- h. **Do not let familiarity gained from frequent use of tools allow you to become complacent and ignore tool safety principles.** *A careless action can cause severe injury within a fraction of a second.*
- i. Only use safety equipment that has been approved by an appropriate standards agency. Unapproved safety equipment may not provide adequate protection. Eye protection must be ANSI-approved and breathing protection must be NIOSH-approved for the specific hazards in the work area.
- j. Do not lay the tool down until it has come to a complete stop. Moving parts can grab the surface and pull the tool out of your control.
- k. When using a handheld power tool, maintain a firm grip on the tool with both hands to resist starting torque.
- l. Do not depress the spindle lock when starting or during operation.
- m. Do not leave the tool unattended when the Battery Pack is connected. Turn off the tool, and remove the Battery Pack before leaving.
- n. This product is not a toy. Keep it out of reach of children.
- o. People with pacemakers should consult their physician(s) before use. Electromagnetic fields in close proximity to heart pacemaker could cause pacemaker interference or pacemaker failure.
- p. The warnings, precautions, and instructions discussed in this instruction manual cannot cover all possible conditions and situations that may occur. It must be understood by the operator that common sense and caution are factors which cannot be built into this product, but must be supplied by the operator.

4. Power tool use and care

- a. **Do not force the power tool. Use the correct power tool for your application.** *The correct power tool will do the job better and safer at the rate for which it was designed.*
- b. **Do not use the power tool if the switch does not turn it on and off.** *Any power tool that cannot be controlled with the switch is dangerous and must be repaired.*

- c. **Disconnect the plug from the power source and/or remove the battery pack, if detachable, from the power tool before making any adjustments, changing accessories, or storing power tools.** *Such preventive safety measures reduce the risk of starting the power tool accidentally.*
 - d. **Store idle power tools out of the reach of children and do not allow persons unfamiliar with the power tool or these instructions to operate the power tool.** *Power tools are dangerous in the hands of untrained users.*
 - e. **Maintain power tools and accessories. Check for misalignment or binding of moving parts, breakage of parts and any other condition that may affect the power tool's operation. If damaged, have the power tool repaired before use.** *Many accidents are caused by poorly maintained power tools.*
 - f. **Keep cutting tools sharp and clean.** *Properly maintained cutting tools with sharp cutting edges are less likely to bind and are easier to control.*
 - g. **Use the power tool, accessories and tool bits etc. in accordance with these instructions, taking into account the working conditions and the work to be performed.** *Use of the power tool for operations different from those intended could result in a hazardous situation.*
 - h. **Keep handles and grasping surfaces dry, clean and free from oil and grease.** *Slippery handles and grasping surfaces do not allow for safe handling and control of the tool in unexpected situations.*
5. **Service**
- a. **Have your power tool serviced by a qualified repair person using only identical replacement parts.** *This will ensure that the safety of the power tool is maintained.*
 - b. Maintain labels and nameplates on the tool. These carry important safety information. If unreadable or missing, contact Harbor Freight Tools for a replacement.
6. **Cutting procedures**
- a. **▲DANGER: Keep hands away from cutting area and the blade. Keep your second hand on auxiliary handle, or motor housing.** *If both hands are holding the saw, they cannot be cut by the blade.*
 - b. **Do not reach underneath the workpiece.** *The guard cannot protect you from the blade below the workpiece.*
 - c. **Adjust the cutting depth to the thickness of the workpiece.** *Less than a full tooth of the blade teeth should be visible below the workpiece.*
- d. **Never hold the workpiece in your hands or across your leg while cutting. Secure the workpiece to a stable platform.** *It is important to support the work properly to minimise body exposure, blade binding, or loss of control.*
 - e. **Hold the power tool by insulated gripping surfaces, when performing an operation where the cutting tool may contact hidden wiring or its own cord.** *Contact with a "live" wire will also make exposed metal parts of the power tool "live" and could give the operator an electric shock.*
 - f. **When ripping, always use a rip fence or straight edge guide.** *This improves the accuracy of cut and reduces the chance of blade binding.*
 - g. **Always use blades with correct size and shape (diamond versus round) of arbor holes.** *Blades that do not match the mounting hardware of the saw will run off-center, causing loss of control.*
 - h. **Never use damaged or incorrect blade washers or bolt.** *The blade washers and bolt were specially designed for your saw, for optimum performance and safety of operation.*
7. **Kickback causes and related warnings**
- kickback is a sudden reaction to a pinched, jammed or misaligned saw blade, causing an uncontrolled saw to lift up and out of the workpiece toward the operator;
 - when the blade is pinched or jammed tightly by the kerf closing down, the blade stalls and the motor reaction drives the unit rapidly back toward the operator;
 - if the blade becomes twisted or misaligned in the cut, the teeth at the back edge of the blade can dig into the top surface of the wood causing the blade to climb out of the kerf and jump back toward the operator.
- Kickback is the result of saw misuse and/or incorrect operating procedures or conditions and can be avoided by taking proper precautions as given below.
- a. **Maintain a firm grip with both hands on the saw and position your arms to resist kickback forces. Position your body to either side of the blade, but not in line with the blade.** *Kickback could cause the saw to jump backwards, but kickback forces can be controlled by the operator, if proper precautions are taken.*
 - b. **When blade is binding, or when interrupting a cut for any reason, release the trigger and hold the saw motionless in the material until the blade comes to a complete stop. Never attempt to remove the saw from the work or pull the saw backward while the blade is in motion or kickback may occur.** *Investigate and take corrective actions to eliminate the cause of blade binding.*

- c. **When restarting a saw in the workpiece, centre the saw blade in the kerf so that the saw teeth are not engaged into the material.** *If a saw blade binds, it may walk up or kickback from the workpiece as the saw is restarted.*
 - d. **Support large panels to minimise the risk of blade pinching and kickback.** *Large panels tend to sag under their own weight. Supports must be placed under the panel on both sides, near the line of cut and near the edge of the panel.*
 - e. **Do not use dull or damaged blades.** *Unsharpened or improperly set blades produce narrow kerf causing excessive friction, blade binding and kickback.*
 - f. **Blade depth and bevel adjusting locking levers must be tight and secure before making the cut.** *If blade adjustment shifts while cutting, it may cause binding and kickback.*
 - g. **Use extra caution when sawing into existing walls or other blind areas.** *The protruding blade may cut objects that can cause kickback.*
8. **Lower guard function**
- a. **Check the lower guard for proper closing before each use. Do not operate the saw if the lower guard does not move freely and close instantly. Never clamp or tie the lower guard into the open position.** *If the saw is accidentally dropped, the lower guard may be bent. Raise the lower guard with the retracting handle and make sure it moves freely and does not touch the blade or any other part, in all angles and depths of cut.*
 - b. **Check the operation of the lower guard spring. If the guard and the spring are not operating properly, they must be serviced before use.** *Lower guard may operate sluggishly due to damaged parts, gummy deposits, or a build-up of debris.*
 - c. **The lower guard may be retracted manually only for special cuts such as “plunge cuts” and “compound cuts”.** *Raise the lower guard by the retracting handle and as soon as the blade enters the material, the lower guard must be released. For all other sawing, the lower guard should operate automatically.*
 - d. **Always observe that the lower guard is covering the blade before placing the saw down on bench or floor.** *An unprotected, coasting blade will cause the saw to walk backwards, cutting whatever is in its path. Be aware of the time it takes for the blade to stop after switch is released.*
9. **Battery tool use and care**
- a. **Prevent unintentional starting.** *Ensure the switch is in the off-position before connecting to battery pack, picking up or carrying the power tool. Carrying the power tool with your finger on the switch or energizing power tool that have the switch on invites accidents.*
 - b. **Disconnect the battery pack from the power tool before making any adjustments, changing accessories, or storing power tool.** *Such preventive safety measures reduce the risk of starting the power tool accidentally.*
 - c. **Recharge only with the charger specified by the manufacturer.** *A charger that is suitable for one type of battery pack may create a risk of fire when used with another battery pack.*
 - d. **Use power tools only with specifically designated battery packs.** *Use of any other battery packs may create a risk of injury and fire.*
 - e. **When battery pack is not in use, keep it away from other metal objects, like paper clips, coins, keys, nails, screws or other small metal objects, that can make a connection from one terminal to another.** *Shorting the battery terminals together may cause burns or a fire.*
 - f. **Under abusive conditions, liquid may be ejected from the battery; avoid contact.** *If contact accidentally occurs, flush with water. If liquid contacts eyes, additionally seek medical help. Liquid ejected from the battery may cause irritation or burns.*
 - g. **Do not use a battery pack or power tool that is damaged or modified.** *Damaged or modified batteries may exhibit unpredictable behavior resulting in fire, explosion or risk of injury.*
 - h. **Do not expose a battery pack or power tool to fire or excessive temperature.** *Exposure to fire or temperature above 265°F may cause explosion.*
 - i. **Follow all charging instructions and do not charge the battery pack or power tool outside of the temperature range specified in the instructions.** *Charging improperly or at temperatures outside of the specified range may damage the battery and increase the risk of fire.*
 - j. **Have servicing performed by a qualified repair person using only identical replacement parts.** *This will ensure that the safety of the product is maintained.*
 - k. **Do not modify or attempt to repair the power tool or the battery pack except as indicated in the instructions for use and care.**

- i.  The battery Charger gets hot during use. The Charger's heat can build up to unsafe levels and create a fire hazard if it does not receive adequate ventilation, due to an electrical fault, or if it is used in a hot environment. Do not place the Charger on a flammable surface. Do not obstruct any vents on the Charger. **Especially avoid placing the Charger on carpets and rugs; they are not only flammable, but they also obstruct vents under the Charger.** Place the Charger on a stable, solid, nonflammable surface (such as a stable metal workbench or concrete floor) at least 1 foot away from all flammable objects, such as drapes or walls. Keep a fire extinguisher and a smoke detector in the area. Frequently monitor the Charger and Battery Pack while charging.

10. Lithium Battery Safety Warnings



LITHIUM BATTERIES STORE A LARGE AMOUNT OF ENERGY AND WILL VENT FIRE OR EXPLODE IF MISTREATED:

- a. **Keep Battery Pack dry.**
- b. **DO NOT DO ANY OF THE FOLLOWING TO THE BATTERY PACK:**
 - Open,
 - Drop,
 - Short-circuit,
 - Puncture,
 - Incinerate, or
 - **Expose to temperatures greater than 265°F.**
- c. Charge Battery Pack only according to its Charger's instructions.
- d. Inspect Battery Pack before every use; do not use or charge if damaged.

11. Vibration Safety

This tool vibrates during use.

Repeated or long-term exposure to vibration may cause temporary or permanent physical injury, particularly to the hands, arms and shoulders. To reduce the risk of vibration-related injury:

- a. Anyone using vibrating tools regularly or for an extended period should first be examined by a doctor and then have regular medical check-ups to ensure medical problems are not being caused or worsened from use. Pregnant women or people who have impaired blood circulation to the hand, past hand injuries, nervous system disorders, diabetes, or Raynaud's Disease should not use this tool. If you feel any symptoms related to vibration (such as tingling, numbness, and white or blue fingers), seek medical advice as soon as possible.
- b. Do not smoke during use. Nicotine reduces the blood supply to the hands and fingers, increasing the risk of vibration-related injury.
- c. Wear suitable gloves to reduce the vibration effects on the user.
- d. Use tools with the lowest vibration when there is a choice.
- e. Include vibration-free periods each day of work.
- f. Grip tool as lightly as possible (while still keeping safe control of it). Let the tool do the work.
- g. To reduce vibration, maintain the tool as explained in this manual. If any abnormal vibration occurs, stop use immediately.

Grounding

⚠️ WARNING



TO PREVENT ELECTRIC SHOCK AND DEATH FROM INCORRECT GROUNDING: Check with a qualified electrician if you are in doubt as to whether the outlet is properly grounded. Do not modify the power cord plug provided with the charger. Do not use the charger if the power cord or plug is damaged. If damaged, have it repaired by a service facility before use. If the plug will not fit the outlet, have a proper outlet installed by a qualified electrician.

Extension Cords

Note: Extension cords must not be used with this item's Charger.

Symbology

	Double Insulated		Read the manual before set-up and/or use.
V	Volts		WARNING marking concerning Risk of Fire. Do not cover Charger ventilation ducts. Charge on fireproof surface only.
	Direct Current		WARNING marking concerning Risk of Electric Shock. Properly connect Charger's power cord to appropriate outlet.
A	Amperes		WARNING marking concerning Risk of Explosion. Do not puncture, short, or open battery packs and do not charge damaged battery packs.
n ₀ xxxx/min.	No Load Revolutions per Minute (RPM)		
	WARNING marking concerning Risk of Eye Injury. Wear ANSI-approved safety goggles with side shields.		

Bauer™

Specifications

Battery Pack	Bauer 20V Li-Ion 64816 63631 (sold separately)
Charger	Bauer 20V Li-Ion 63947 63529 (sold separately)
No Load Speed	n_0 : 4000/min
Maximum Blade Diameter	5-3/8" (136mm)
Arbor	20mm round
Maximum Depth of Cut	Metal Only: 1.8" (46mm)

Setup - Before Use:



Read the **ENTIRE IMPORTANT SAFETY INFORMATION** section at the beginning of this manual including all text under subheadings therein before set up or use of this product.

Note: For additional information regarding the parts listed in the following pages, refer to *Parts List and Diagram* on page 14.

Charging

Charge battery before using this tool. Follow instructions included with battery charger. Battery Pack and Charger sold separately.

Work Area

1. Designate a work area that is clean and well lit. The work area must not allow access by children or pets to prevent distraction and injury.
2. There must not be objects, such as utility lines, nearby that will present a hazard while working.

Saw Blade Selection

1. Any saw blade that will be used must be marked as suitable for the material to be cut.
 2. Use only a saw blade diameter in accordance with the markings on the saw. See *Specifications Table* for the bore diameter.
 3. Use only metal cutting saw blades that are marked with a speed equal or higher than the speed marked on the tool.
- CAUTION:** This saw is designed for metal cutting only. Only install blades intended for metal cutting. Do not use for cutting wood.

Guard Setup

Check that the Lower Blade Guard is in place, moves freely, and closes instantly.

Functions

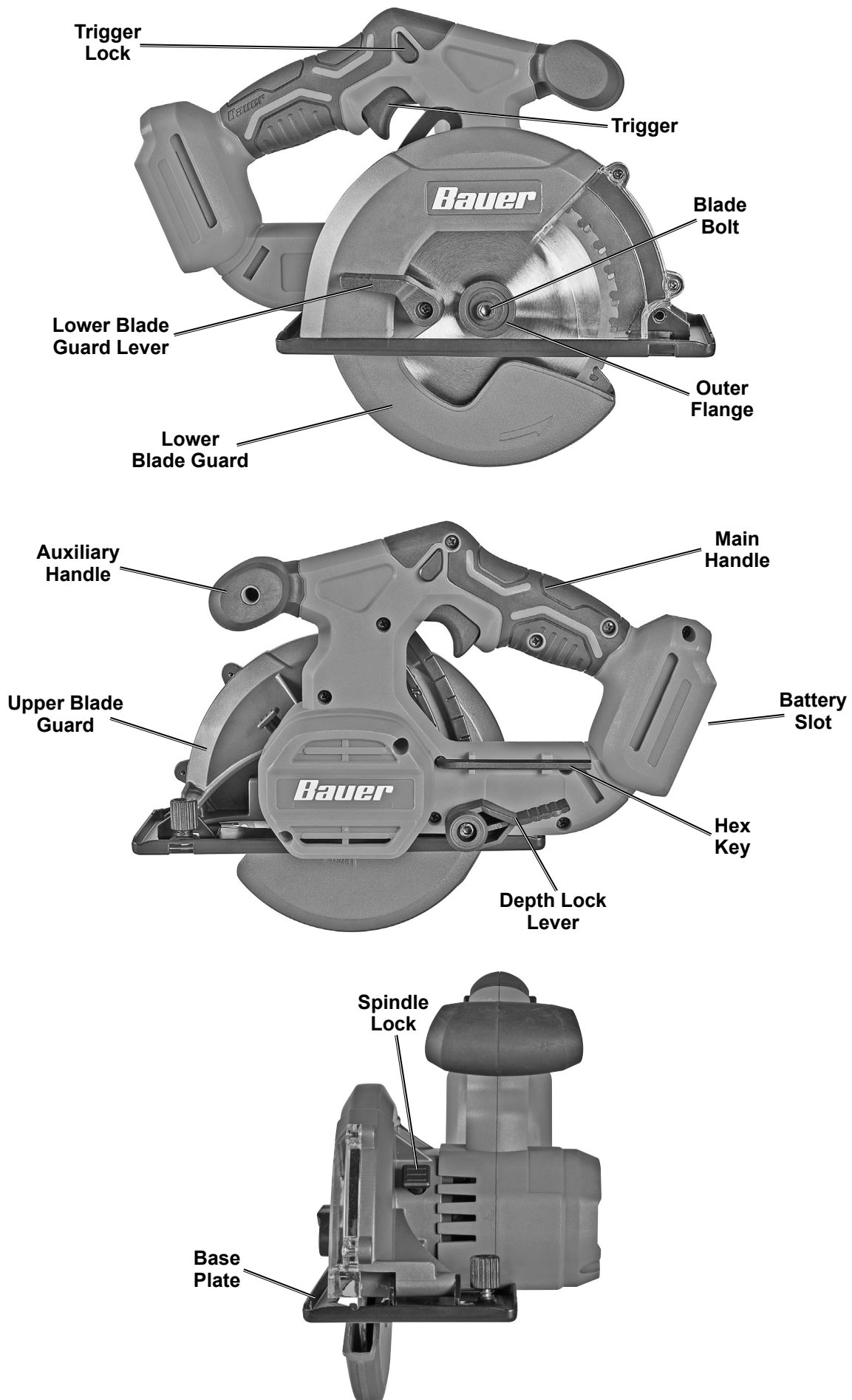

SAFETY

SETUP

OPERATION

MAINTENANCE

Operating Instructions



Read the **ENTIRE IMPORTANT SAFETY INFORMATION** section at the beginning of this manual including all text under subheadings therein before set up or use of this product.

Tool Changing

⚠ WARNING

TO PREVENT SERIOUS INJURY FROM ACCIDENTAL OPERATION: Make sure that the Trigger is in the off-position and remove the Battery Pack before performing any procedure in this section.

TO PREVENT SERIOUS INJURY FROM FLYING FRAGMENTS:

Do not use blades designed for cutting wood. Only install blades intended for metal cutting.

Mounting and Removing Blade

1. Hold in the Spindle Lock while removing the Blade Bolt using the Hex Key, turning Bolt **COUNTERCLOCKWISE**.
2. Remove the Outer Flange.
3. Use the lever on the Lower Guard to raise the Guard and remove the Blade. Leave the Inner Flange in place.
4. Install the new metal cutting blade (sold separately) with the directional arrow on the blade pointing the same as the directional arrow on the Lower Guard.
5. Place the Outer Flange on the Spindle, recessed side first.
6. Hold in the Spindle Lock while using the Hex Key to replace the Blade Bolt, turning it **CLOCKWISE**. Tighten securely.

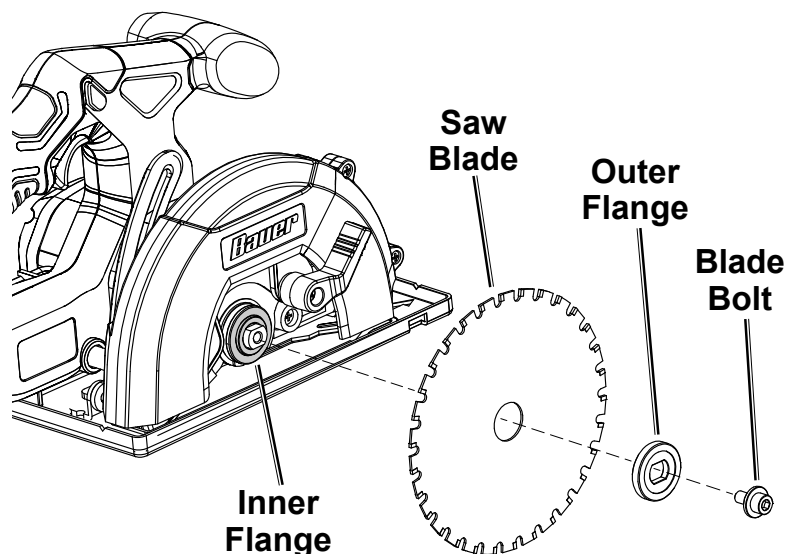

Setting and Testing

⚠ WARNING

TO PREVENT SERIOUS INJURY FROM ACCIDENTAL OPERATION: Make sure that the Trigger is in the off-position and remove the Battery Pack before performing any procedure in this section.

Adjusting Depth

1. Grip the Saw by the Main Handle and loosen the Depth Lock Lever by pulling it up to allow the depth of cut to be adjusted.
2. Raise or lower the Base Plate to the desired position using the Depth Scale to set depth of cut.

WARNING! To reduce the risk of serious injury, adjust the depth of cut to just barely clear the workpiece and remove shavings.

3. After adjustment, tighten the Depth Lock Lever by pushing it down.

WARNING! TO PREVENT SERIOUS INJURY: Tighten Depth Lock Lever before use.

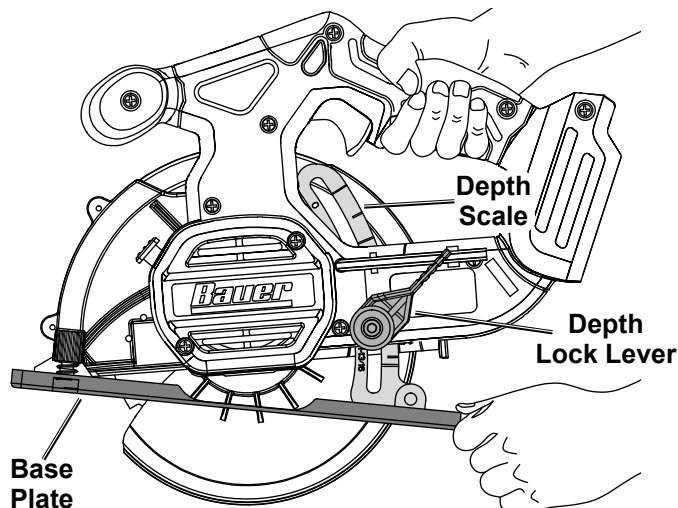

Workpiece Set Up

1. Secure loose workpieces using a vise or clamps (not included) to prevent movement while working.
2. There must not be objects, such as utility lines, nearby that will present a hazard while working.
3. Refer to the *Specifications Table* on page 8 for limitations on workpiece size.

General Instructions for Use

1. Make all necessary adjustments to the Circular Saw.
 2. **Make sure that all guards are in place and in proper working order and that all adjustment knobs and levers are tight before operation.**
 3. Make sure that the Trigger is in the off-position, then attach a 20V Bauer Battery Pack (sold separately).
 4. Before making the first cut, study the procedure and practice with scrap metal.
 5. Position the Saw Blade about 1/2" from the beginning of the marked cut line on the workpiece. Do not allow the Saw Blade to come in contact with the workpiece.
 6. Align the marked cut line with the notch on the Base Plate.
 7. Firmly grip the Main Handle with one hand and the Auxiliary Handle with the other hand.
 8. Depress and hold the Trigger Lock and squeeze the Trigger to turn on the Saw.
 9. Allow the Saw Blade to spin up to full speed before feeding the Saw Blade into the workpiece.
 10. Do not force the Saw to remove material faster than it was designed to cut. Make sure to feed the Saw Blade gradually into the workpiece.
 11. Once the cutting job is completed, turn off the Saw and wait until the Saw Blade has stopped rotating.
- WARNING!** The tool will restart automatically if stalled.
12. To prevent accidents, turn off the tool and remove its Battery Pack after use. Clean, then store the tool indoors out of children's reach.

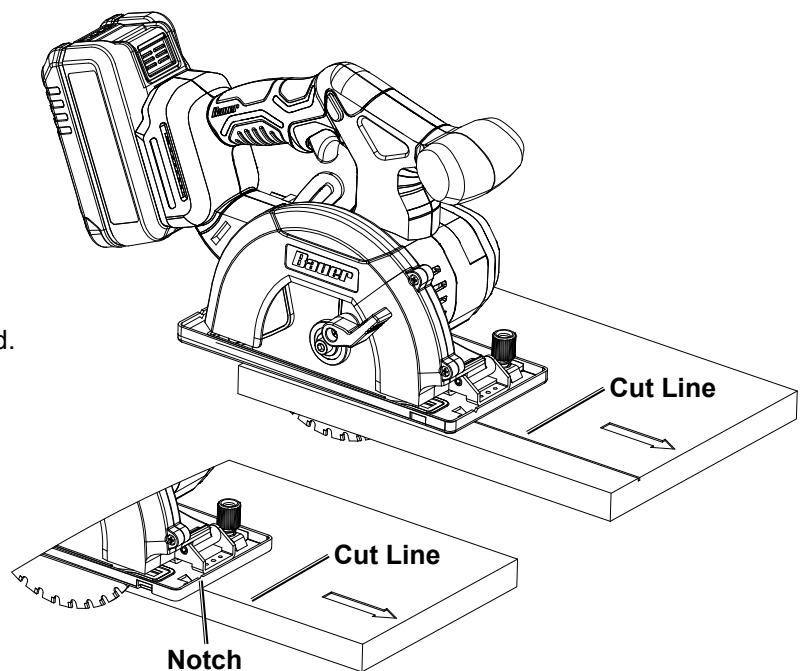

Bauer™

Maintenance and Servicing Instructions



Procedures not specifically explained in this manual must be performed only by a qualified technician.

WARNING

TO PREVENT SERIOUS INJURY FROM ACCIDENTAL OPERATION:
Make sure that the Trigger is in the off-position and remove its Battery Pack before performing any procedure in this section.

TO PREVENT SERIOUS INJURY FROM TOOL FAILURE:
Do not use damaged equipment. If abnormal noise or vibration occurs, have the problem corrected before further use.

Cleaning, Maintenance, and Lubrication

1. **BEFORE EACH USE**, inspect the general condition of the Tool. Check for:
 - leaking, swollen, or cracked battery pack
 - loose hardware
 - misalignment or binding of moving parts
 - cracked or broken parts
 - any other condition that may affect its safe operation.
2. **AFTER USE**, wipe external surfaces of the Tool with clean cloth.
3. **Li-Ion BATTERY MUST BE RECYCLED OR DISPOSED OF PROPERLY.**
Do not short, incinerate or open battery.
4. For blade changing instructions see *Tool Changing* on page 10.
5. Disconnect Battery Pack and store Battery Pack, Charger, and Tool in dry, indoor area out of reach of children and away from metal objects (i.e., paperclips, coins) to prevent shorting.

Troubleshooting

Problem	Possible Causes	Likely Solutions
Tool will not start.	<ol style="list-style-type: none"> 1. Battery Pack not properly connected. 2. Battery Pack not properly charged. 3. Battery Pack stopped working. 4. Internal damage or wear. (Trigger, for example.) 	<ol style="list-style-type: none"> 1. Remove Battery Pack, make sure there are no obstructions, reinsert the Battery Pack according to its shape (it should only fit one way), and press firmly until the Battery Pack locks in place. 2. Make sure Charger is connected and operating properly. Give enough time for Battery Pack to recharge properly. 3. Dispose of old Battery Pack properly or recycle. Replace Battery Pack. 4. Have technician service tool.
Tool operates slowly.	<ol style="list-style-type: none"> 1. Forcing tool to work too fast. 2. Battery Pack wearing out. 	<ol style="list-style-type: none"> 1. Allow tool to work at its own rate. 2. Dispose of old Battery Pack properly or recycle. Replace Battery Pack.
Performance decreases over time.	Blade dull or damaged.	Keep blades sharp. Replace as needed.
Excessive noise or rattling.	Internal damage or wear. (Bearings, for example.)	Have technician service tool.
Overheating.	<ol style="list-style-type: none"> 1. Forcing tool to work too fast. 2. Blade misaligned. 3. Blade dull or damaged. 4. Blocked motor housing vents. 	<ol style="list-style-type: none"> 1. Allow tool to work at its own rate. 2. Check and correct blade alignment. 3. Keep blades sharp. Replace as needed. 4. Wear ANSI-approved safety goggles and NIOSH-approved dust mask/respirator while blowing dust out of motor using compressed air.



Follow all safety precautions whenever diagnosing or servicing the tool. Disconnect Battery Pack and Charger power supply before service.

SAFETY

SETUP

OPERATION

MAINTENANCE

PLEASE READ THE FOLLOWING CAREFULLY

THE MANUFACTURER AND/OR DISTRIBUTOR HAS PROVIDED THE PARTS LIST AND ASSEMBLY DIAGRAM IN THIS MANUAL AS A REFERENCE TOOL ONLY. NEITHER THE MANUFACTURER OR DISTRIBUTOR MAKES ANY REPRESENTATION OR WARRANTY OF ANY KIND TO THE BUYER THAT HE OR SHE IS QUALIFIED TO MAKE ANY REPAIRS TO THE PRODUCT, OR THAT HE OR SHE IS QUALIFIED TO REPLACE ANY PARTS OF THE PRODUCT. IN FACT, THE MANUFACTURER AND/OR DISTRIBUTOR EXPRESSLY STATES THAT ALL REPAIRS AND PARTS REPLACEMENTS SHOULD BE UNDERTAKEN BY CERTIFIED AND LICENSED TECHNICIANS, AND NOT BY THE BUYER. THE BUYER ASSUMES ALL RISK AND LIABILITY ARISING OUT OF HIS OR HER REPAIRS TO THE ORIGINAL PRODUCT OR REPLACEMENT PARTS THERETO, OR ARISING OUT OF HIS OR HER INSTALLATION OF REPLACEMENT PARTS THERETO.

Parts List

Part	Description	Qty
1	Hex Key	1
2	Torx Screw St3.5x14	12
3	Left Housing	1
4	Rubber Column	1
5	Trigger	1
6	Self-Locking Spring	1
7	Trigger Lock Return Spring	1
8	Trigger Lock	1
9	Micro Switch	1
10	Motor Controller	1
11	Connecting Bracket	1
12	Screw M4x14	9
13	Right Housing	1
14	Screw M4x14	6
15	Upper Motor Cover	1
16	Brushless Stator	1
17	Lower Motor Cover	1
18	Bearing 605-2RS	4
19	Brushless Rotor Assembly	1
20	Bearing 608-2RS	1
21	Felt Ring	1
22	O-Ring	1
23	Spindle Lock Button	1
24	Cylindrical Screw M5x14	1
25	Depth Lever	1
26	Depth Lock Rod	1
27	Washer 18x6x2	1
28	Upper Blade Guard	1
29	Transparent Guard	1
30	Screw M3x12	2
31	Spindle Lock Bracket	1
32	Spindle Lock Return Spring	1
33	Felt Ring	1

Part	Description	Qty
34	Self-Locking Plate	1
35	Pan Head Screw M3x8	2
36	Lower Guard Circlip	1
37	Rubber Screw	1
38	Edge Guide Lock Knob M6	1
39	Edge Guide Lock Knob Spring	1
40	Large Washer	1
41	Depth Scale	1
42	Square Neck Bolt M6x18	1
43	Base Plate Assembly	1
44	Rivet Φ6x8	1
45	Elastic Cylindrical Pin	1
46	Needle Bearing HK081210	1
47	Circlip	1
48	Wave Washer Φ9	1
49	Gear	1
50	Gear Block	1
51	Circlip	1
52	Bearing 6900-2RS	1
53	Front Cover	1
54	Screw M4x14	3
55	Woodruff Key 2.5x10	1
56	Spindle	1
57	Protective Ring	1
58	Reset Spring	1
59	Lower Blade Guard	1
60	Lower Blade Guard Lever	1
61	Circlip	1
62	Inner Flange	1
63	Saw Blade (sold separately)	1
64	Outer Flange	1
65	Blade Bolt with Washer M6x14	1

Record Product's Serial Number Here: _____

Note: If product has no serial number, record month and year of purchase instead.

Note: Some parts are listed and shown for illustration purposes only, and are not available individually as replacement parts. Specify UPC 193175434845 when ordering parts.

Assembly Diagram

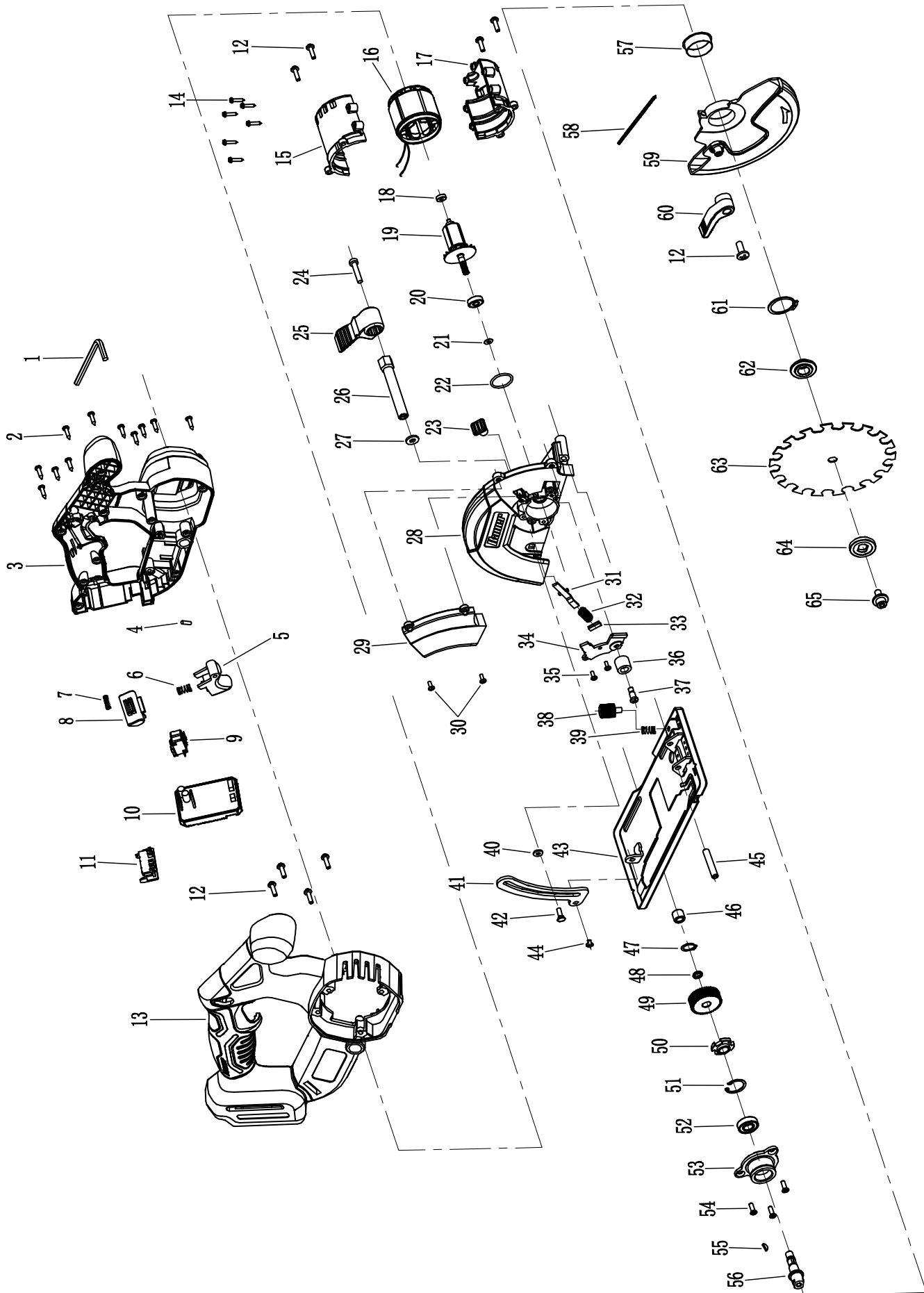

Limited 90 Day Warranty

Harbor Freight Tools Co. makes every effort to assure that its products meet high quality and durability standards, and warrants to the original purchaser that this product is free from defects in materials and workmanship for the period of 90 days from the date of purchase. This warranty does not apply to damage due directly or indirectly, to misuse, abuse, negligence or accidents, repairs or alterations outside our facilities, criminal activity, improper installation, normal wear and tear, or to lack of maintenance. We shall in no event be liable for death, injuries to persons or property, or for incidental, contingent, special or consequential damages arising from the use of our product. Some states do not allow the exclusion or limitation of incidental or consequential damages, so the above limitation of exclusion may not apply to you. THIS WARRANTY IS EXPRESSLY IN LIEU OF ALL OTHER WARRANTIES, EXPRESS OR IMPLIED, INCLUDING THE WARRANTIES OF MERCHANTABILITY AND FITNESS.

To take advantage of this warranty, the product or part must be returned to us with transportation charges prepaid. Proof of purchase date and an explanation of the complaint must accompany the merchandise. If our inspection verifies the defect, we will either repair or replace the product at our election or we may elect to refund the purchase price if we cannot readily and quickly provide you with a replacement. We will return repaired products at our expense, but if we determine there is no defect, or that the defect resulted from causes not within the scope of our warranty, then you must bear the cost of returning the product.

This warranty gives you specific legal rights and you may also have other rights which vary from state to state.

The logo for Bauer, featuring the word "Bauer" in a bold, italicized, sans-serif font. The letters are black with a white outline, and a small trademark symbol (TM) is located at the bottom right of the letter "r".

26677 Agoura Road • Calabasas, CA 91302 • 1-888-866-5797