

# Owner's Manual & Safety Instructions

**Save This Manual** Keep this manual for the safety warnings and precautions, assembly, operating, inspection, maintenance and cleaning procedures. Write the product's serial number in the back of the manual near the assembly diagram (or month and year of purchase if product has no number). Keep this manual and the receipt in a safe and dry place for future reference.

21d



58293

## 5,000 lb Capacity 2.5 Ton Pallet Jack



Visit our website at: <http://www.harborfreight.com>  
Email our technical support at: [productsupport@harborfreight.com](mailto:productsupport@harborfreight.com)

When unpacking, make sure that the product is intact and undamaged. If any parts are missing or broken, please call 1-888-866-5797 as soon as possible.

Copyright© 2020 by Harbor Freight Tools®. All rights reserved.  
No portion of this manual or any artwork contained herein may be reproduced in any shape or form without the express written consent of Harbor Freight Tools. Diagrams within this manual may not be drawn proportionally. Due to continuing improvements, actual product may differ slightly from the product described herein.  
Tools required for assembly and service may not be included.

### **⚠ WARNING**

Read this material before using this product.  
Failure to do so can result in serious injury.  
**SAVE THIS MANUAL.**

# Table of Contents





Safety .....	2	Maintenance .....	7
Specifications .....	3	Parts Lists and Diagrams .....	8
Setup .....	4	Warranty .....	12
Operation.....	6		

SAFETY

SETUP

OPERATION

MAINTENANCE

WARNING SYMBOLS AND DEFINITIONS	
	This is the safety alert symbol. It is used to alert you to potential personal injury hazards. Obey all safety messages that follow this symbol to avoid possible injury or death.
	Indicates a hazardous situation which, if not avoided, will result in death or serious injury.
	Indicates a hazardous situation which, if not avoided, could result in death or serious injury.
	Indicates a hazardous situation which, if not avoided, could result in minor or moderate injury.
	Addresses practices not related to personal injury.

## IMPORTANT SAFETY INFORMATION

### WARNING

**Read all safety warnings and instructions.**  
*Failure to follow the warnings and instructions may result in serious injury and/or property damage.*  
**Save all warnings and instructions for future reference.**

1. **Do not exceed 5,000 lb. capacity. Be aware of dynamic loading! Sudden load movement may briefly create excess load causing product failure.**
2.  **Wear ANSI-approved safety goggles, heavy-duty work gloves, and non-skid footwear during assembly and use.**
3. Use as intended only. Do not use to support people or animals.
4. Do not use for aircraft purposes.
5. Keep clear of fork and load when lifting, moving, and lowering.
6. Only use on flat, level surface able to withstand weight of Jack and load.
7. Do not leave unattended while under load.
8. Only use with balanced, properly secured load.
9. Inspect before every use; do not use if parts loose or damaged.
10. This product is not a toy. Do not allow children to play with or near this item.
11. Keep work area clean and well lit. Cluttered or dark areas invite accidents.
12. Stay alert, watch what you are doing and use common sense when using this Jack. **Do not use while you are tired or under the influence of drugs, alcohol or medication.** A moment of inattention while using may result in serious personal injury.
13. **Check for misalignment or binding of parts, cracks and/or breakage of parts, and any other condition that may affect safe operation.** Many accidents are caused by poorly maintained tools.

- 14. Jack service must be performed only by qualified repair personnel. Service or maintenance performed by unqualified personnel could result in a risk of injury.
- 15. When servicing a jack, use only identical replacement parts. Use of unauthorized parts or failure to follow maintenance instructions may create a risk of injury.
- 16. Maintain labels and nameplates on the Pallet Jack. These carry important safety information. If unreadable or missing, contact Harbor Freight Tools for a replacement.

- 17. The warnings, precautions, and instructions discussed in this instruction manual cannot cover all possible conditions and situations that may occur. It must be understood by the operator that common sense and caution are factors which cannot be built into this product, but must be supplied by the operator.

**IMPORTANT! Before first use:**

Check hydraulic fluid level and fill to the level of the fill hole as needed. Thoroughly test the Jack for proper operation. If it does not work properly, bleed air from its hydraulic system—see instructions on page 6.



**SAVE THESE INSTRUCTIONS.**

**Specifications**

Capacity	2-1/2 Tons (5000 lb.)
Maximum Fork Height	7-1/2"
Minimum Fork Height	3"
Fork Length	48"
Fork Width	6-1/4"
Width over Forks	27"

## Set Up



Read the **ENTIRE IMPORTANT SAFETY INFORMATION** section at the beginning of this manual including all text under subheadings therein before set up or use of this product

Note: For additional information regarding the parts listed in the following pages, refer to *Parts Lists and Diagrams* on page 8.

## Tool Set Up

### Handle Assembly

1. Remove the three Screws (D611) from the Handle Bracket (D151).
2. Set the Handle (D610) on the Handle Bracket. Make sure the Chain (D612), Chain Bolt (D614) and Nut (D615) pass through the large opening in the center of the Handle Bracket and the hole in the center of the Handle Bracket Shaft (D153).
3. Slide a Washer (D616) onto each Screw. Insert the Screws through the base of the Handle into the Handle Bracket and tighten securely with a torque wrench (sold separately) to no more than 43 ft-lb.
4. Raise the Pump Lever (D132) on the Pump and insert the Chain Bolt into the slotted open end, keeping the Nut on the underside of the Pump Lever.

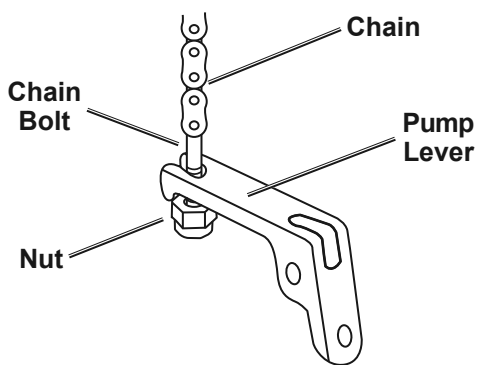

Chain Attachment Detail

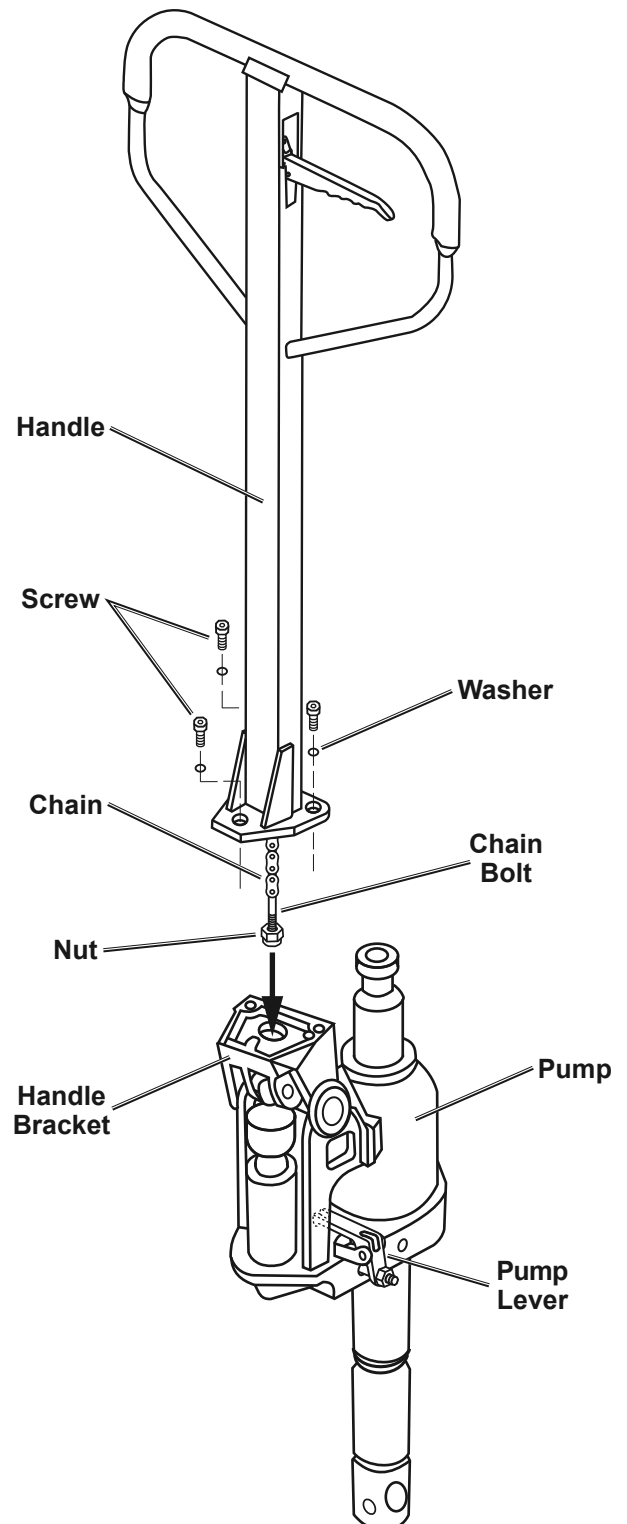

# Control Lever

The Control Lever on the Handle has three operating positions: Lift, Drive and Lower.

- a. Lift – Move the Control Lever down to its lowest position. Pump the Handle frame up and down to lift the Jack Forks.
- b. Drive – Move the Control Lever to the center position. The Jack Forks do not change position when in drive. This position is used when the load is moved from one location to another.
- c. Lower – Hold the Control Lever up in its highest position. This position automatically moves the Forks to their lowest level. This position is only in place as long as the Control Lever is held up. The Lever moves back to the Drive position when released.

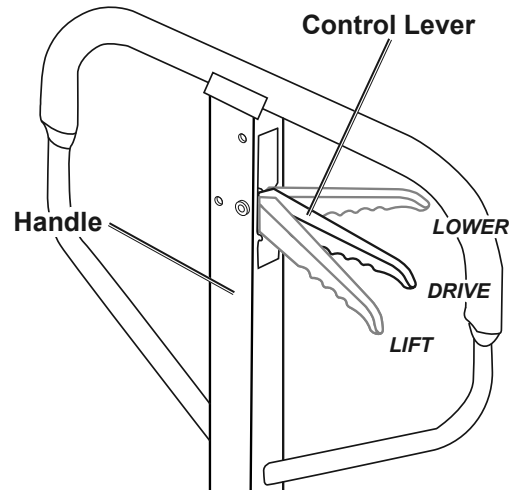

## If the Control Lever Does Not Function Properly

Make adjustments as described in the following chart by loosening the Lock Nut (D134) and turning the Control Adjustment Screw (D133). After each adjustment, tighten the Lock Nut and check that all positions of the Control Lever function properly and re-adjust if needed.

Control Position	Problem	Turn Adjustment Screw (D133):
Drive	Forks rise instead of staying in neutral.	Clockwise until pumping action does not raise forks.
Drive	Forks lower when Control Lever is in <b>DRIVE</b> position.	Counterclockwise until forks do not lower.
Lower	Forks do not lower.	Clockwise until raising the Control Lever to the <b>LOWER</b> position lowers the Forks.
Lift	Forks do not elevate.	Counterclockwise until the Forks elevate while pumping in the <b>LIFT</b> position.

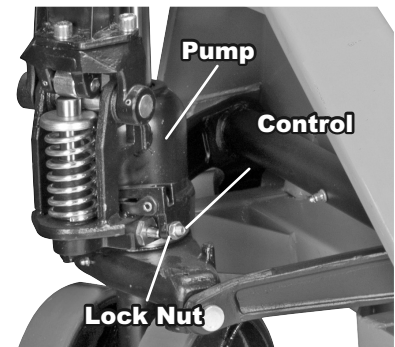
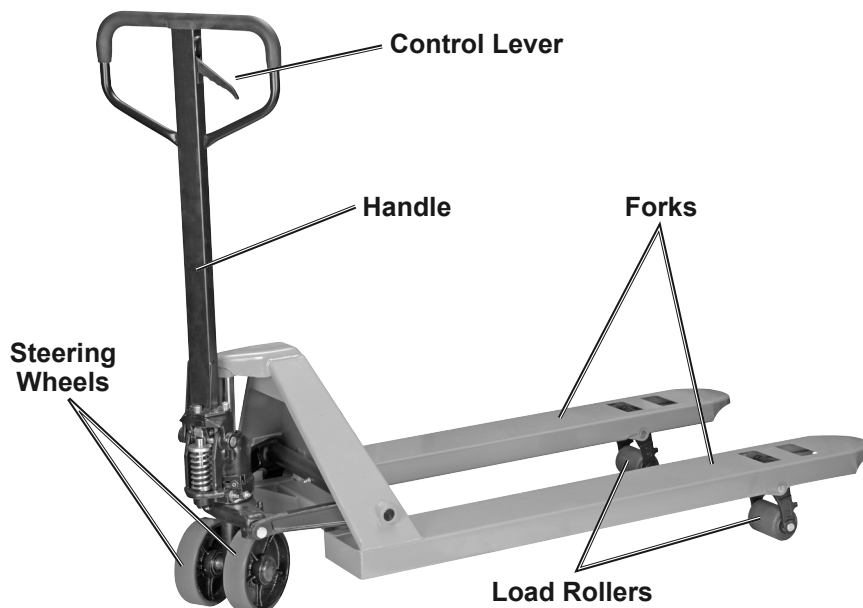

Figure C:

## Components and Controls



## Operating Instructions



Read the **ENTIRE IMPORTANT SAFETY INFORMATION** section at the beginning of this manual including all text under subheadings therein before set up or use of this product.

### Bleeding

**IMPORTANT!** Before first use and before each use thereafter, check for proper hydraulic fluid level in the Pump and add fluid to the level of the fill hole if necessary.

Then thoroughly test the Jack for proper operation prior to its actual use.

If the Jack appears *not* to be working properly, it may be necessary to *bleed* its hydraulic system of excess air.

1. Hold the Control Lever (D608) in the **LOWER** position to lower the Forks.
2. Remove the Fluid Fill Plug (D149) from the side of the Pump.
3. Pump the Handle (D610) up and down several times while holding the Control Lever in the **LOWER** position to purge excess air from the system.
4. Check the fill hole (where the Fluid Fill Plug was removed from) and, if necessary, add hydraulic fluid up to the level of the fill hole.
5. Replace the Fluid Fill Plug.
6. Test the Jack several times for proper operation before attempting to lift a load. **If the Jack still does not appear to be working properly after bleeding, do not use the Jack until it has been repaired by a qualified service technician.**

### General Operating Instructions

1. Hold the Control Lever in the **LOWER** position to lower the Forks, then release the Control Lever.
2. Slide the Pallet Jack under the load, being careful to center the load over the Forks. Have the main weight of the load resting as near as possible to the Steering Wheels.
3. Push the Control Lever down to the **LIFT** position, then pump the Handle until the load is raised off the floor and is resting on the Forks.
4. Move the Control Lever to the **DRIVE** position and roll the load to the desired location.
5. Hold the Control Lever in the **LOWER** position to lower the Forks, then release the Control Lever.
6. Slide the Forks out from under the load.
7. When finished using the Jack, hold the Control Lever in the **LOWER** position to lower the Forks completely.
8. Store in a safe, dry location out of reach of children.

**WARNING!** To prevent serious injury from tipping, raise the load as little as possible before moving.

## Maintenance and Servicing



Procedures not specifically explained in this manual must be performed only by a qualified technician.

### **⚠️ WARNING**

**TO PREVENT SERIOUS INJURY FROM TOOL FAILURE:** Do not use damaged equipment. If abnormal noise or vibration occurs, have the problem corrected before further use.

## Cleaning, Maintenance, and Lubrication

1. **BEFORE EACH USE**, inspect the general condition of the Pallet Jack. Check for:
  - cracked, broken or bent parts
  - loose or missing parts
  - misalignment of parts
  - any other condition that may affect its safe operation.

If a problem occurs, have the problem corrected before further use. **Do not use damaged equipment.**
2. Before each use, thoroughly test the Jack for proper operation prior to its actual use. If the Jack appears not to be working properly, follow Bleeding instructions on page 6.
3. Periodically inject grease into the grease fittings.
4. **AFTER USE**, lower Jack completely to help prevent rusting of the Piston Rod. Clean external surfaces with clean cloth. Store the Jack in a safe, dry location out of reach of children.

## Troubleshooting

### **⚠️ WARNING**

**TO PREVENT SERIOUS INJURY:** Use caution when troubleshooting a malfunctioning jack. Stay well clear of the supported load. Completely resolve all problems before use.

If the solutions presented in the Troubleshooting guide do not solve the problem, have a qualified technician inspect and repair the Jack before use. **After the Jack is repaired: Test it carefully without a load by raising it and lowering it fully, checking for proper operation, BEFORE RETURNING THE JACK TO OPERATION.**

**DO NOT USE A DAMAGED OR MALFUNCTIONING JACK!**

Problem	Possible Causes	Likely Solutions
The Forks do not raise completely.	Insufficient hydraulic fluid.	Refill Pump with hydraulic fluid.
The Forks will not raise.	<ol style="list-style-type: none"> <li>1. Insufficient hydraulic fluid.</li> <li>2. Air in valve chamber.</li> <li>3. Control Lever out of adjustment.</li> <li>4. Old/contaminated fluid.</li> </ol>	<ol style="list-style-type: none"> <li>1. Refill Pump with hydraulic fluid.</li> <li>2. Bleed hydraulic system—see page 6.</li> <li>3. Adjust Control Lever—see page 5.</li> <li>4. Change fluid and replace Seals.</li> </ol>
The Forks will not descend.	<ol style="list-style-type: none"> <li>1. Control Lever out of adjustment.</li> <li>2. Piston Rod rusted.</li> <li>3. Deformed Piston Rod.</li> <li>4. Control Lever, Chain, Chain Bolt, or Nut broken or missing.</li> </ol>	<ol style="list-style-type: none"> <li>1. Adjust Control Lever—see page 5.</li> <li>2. Lubricate/replace Rod.</li> <li>3. Replace Piston Rod and cylinder.</li> <li>4. Replace the Handle Assembly.</li> </ol>
Fluid leak.	Component, likely seal, worn or damaged.	Inspect and replace worn or damaged parts.
Forks descend without operating release valve.	<ol style="list-style-type: none"> <li>1. Control Lever out of adjustment.</li> <li>2. Contaminated hydraulic fluid clogging valve.</li> <li>3. Hydraulic component damaged.</li> </ol>	<ol style="list-style-type: none"> <li>1. Adjust Control Lever—see page 5.</li> <li>2. Clean valve with kerosene and change hydraulic fluid.</li> <li>3. Replace damaged part.</li> </ol>



**Follow safety precautions whenever diagnosing or servicing the tool.**

**PLEASE READ THE FOLLOWING CAREFULLY**

THE MANUFACTURER AND/OR DISTRIBUTOR HAS PROVIDED THE PARTS LIST AND ASSEMBLY DIAGRAM IN THIS MANUAL AS A REFERENCE TOOL ONLY. NEITHER THE MANUFACTURER OR DISTRIBUTOR MAKES ANY REPRESENTATION OR WARRANTY OF ANY KIND TO THE BUYER THAT HE OR SHE IS QUALIFIED TO MAKE ANY REPAIRS TO THE PRODUCT, OR THAT HE OR SHE IS QUALIFIED TO REPLACE ANY PARTS OF THE PRODUCT. IN FACT, THE MANUFACTURER AND/OR DISTRIBUTOR EXPRESSLY STATES THAT ALL REPAIRS AND PARTS REPLACEMENTS SHOULD BE UNDERTAKEN BY CERTIFIED AND LICENSED TECHNICIANS, AND NOT BY THE BUYER. THE BUYER ASSUMES ALL RISK AND LIABILITY ARISING OUT OF HIS OR HER REPAIRS TO THE ORIGINAL PRODUCT OR REPLACEMENT PARTS THERETO, OR ARISING OUT OF HIS OR HER INSTALLATION OF REPLACEMENT PARTS THERETO.

**Handle Parts List and Diagram**

Part	Description	Qty
D601	Spring	1
D602	Blade Spring	1
D603	Roller	1
D604	Spring Pin	1
D605	Spring Pin	1
D606	Spring Pin	1
D607	Spring Pin	1
D608	Control Lever	1

Part	Description	Qty
D609	Pull Board	1
D610	Handle	1
D611	Screw	3
D612	Chain	1
D613	Pin	1
D614	Chain Bolt	1
D615	Nut	1
D616	Washer	3

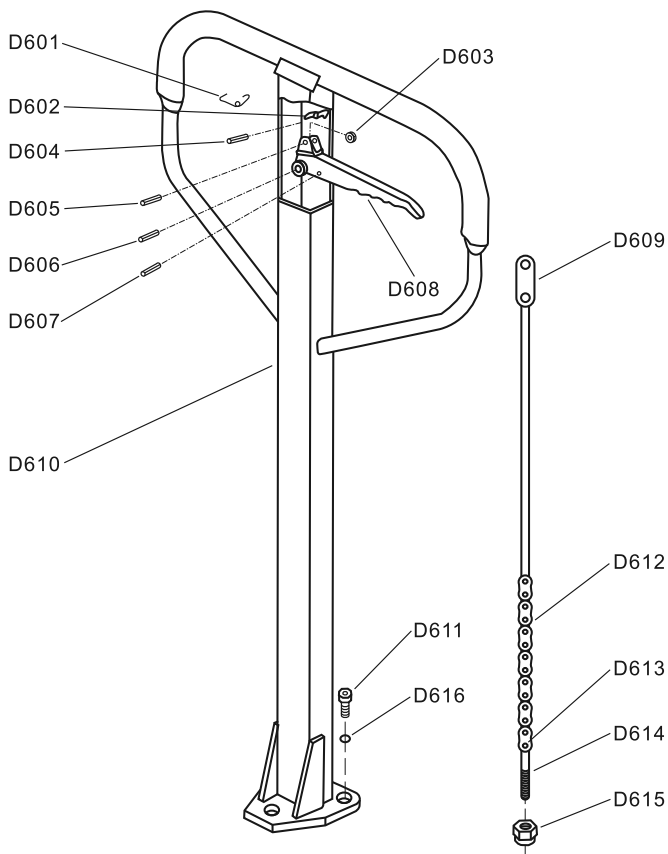

SAFETY

SETUP

OPERATION

MAINTENANCE



# Fork Frame Parts List and Diagram

Part	Description	Qty
D201	Screw	1
D202	Oil Fitting	1
D203	Rocker Arm	1
D204	Spring Pin	1
D205	Retaining Ring	2
D206	Joint	2
D207	Shaft	2
D208	Push Rod	2
D209	Nut	2
D210	Pin	2
D211	Shaft	1
D212	Roller Frame Shaft	2
D213	Spring Pin	2
D214	Push Rod Shaft	2

Part	Description	Qty
D215	Roller Frame	2
D216	Spring Pin	2
D218	Fork Frame	1
D219	Washer	4
D220	Bearing	4
D223	Spring Pin	4
D224	Bushing	4
D225	Bushing	2
D226	Bolt	2
D227	Entry Roller	2
D228	Nut	2
D229	Load Roller	2
D230	Roller Shaft	2
D231	Washer	2
D232	Washer	4

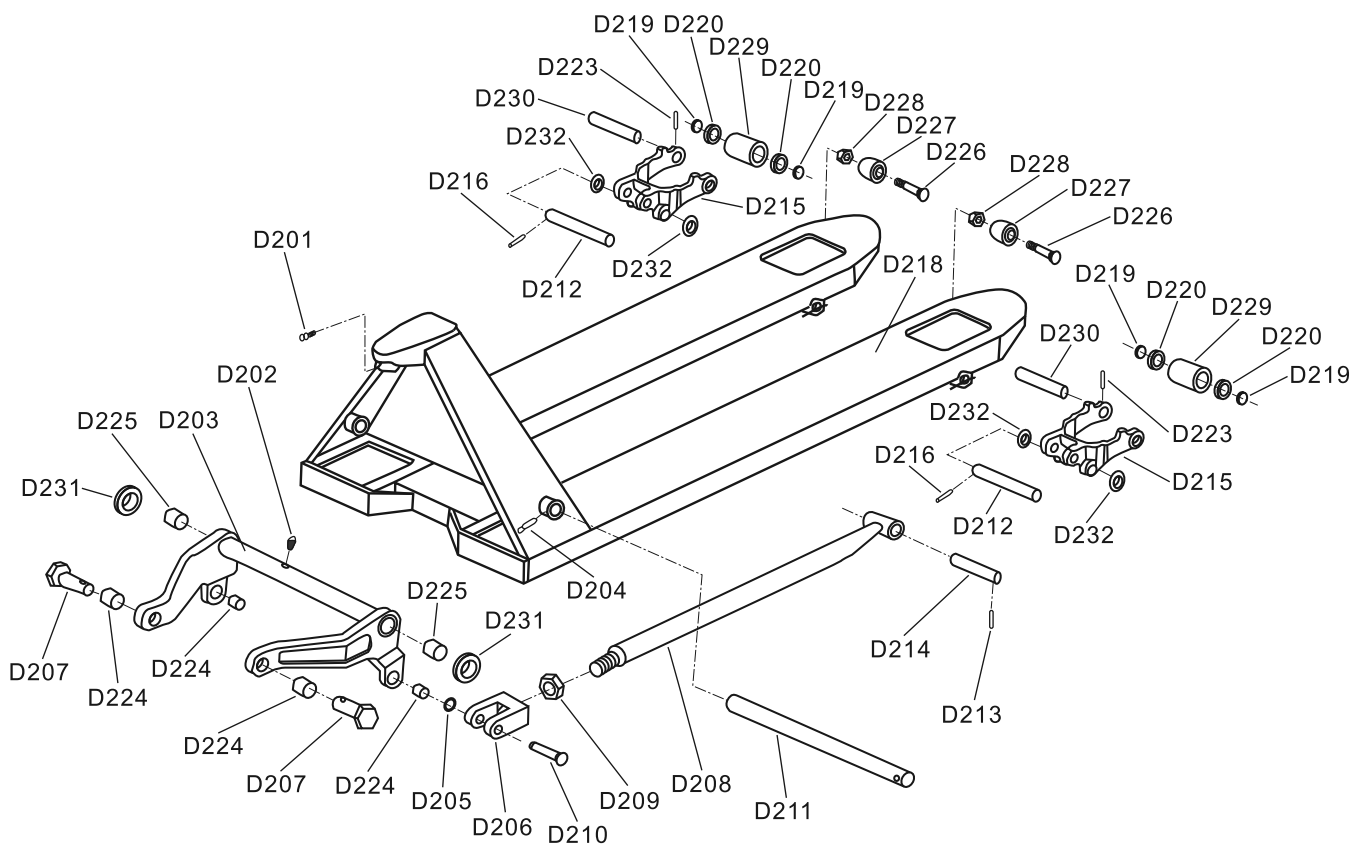

SAFETY

SETUP

OPERATION

MAINTENANCE

# Pump Parts List

SAFETY

SETUP

OPERATION

MAINTENANCE

Part	Description	Qty
D101	Pump Piston Rod	1
D102	Washer	1
D103	Spring	1
D104	Dust Ring	1
D105	Y-Seal	1
D106	Screw	1
D107	O-Ring	1
D108	Spring	1
D109	Pump Valve Spindle	1
D110	Pump Valve Seat	1
D111	O-Ring	1
D112	Steel Ball	1
D113	Pump Body	1
D115	Spring Pin	1
D116	Steering Wheel	2
D117	Wheel Shaft	1
D118	Thrust Plate	1
D119	Oil Fitting	1
D120	Retaining Ring	1
D121	Bearing Cover	1
D122	Bearing	1
D123	Spring Pin	2
D124	Dust Cover	2
D125	Retaining Ring	2
D126	Washer	2
D127	Bearing	4
D129	Spring	1
D130	Release Valve	1

Part	Description	Qty
D131	O-Ring	2
D132	Pump Lever	1
D133	Control Adjustment Screw	1
D134	Lock Nut	1
D135	O-Ring	1
D136	Axle Sleeve	1
D137	Adjusting Bolt	1
D139	Safety Valve Spindle	1
D140	Spring	1
D141	O-Ring	1
D142	Screw	1
D143	O-Ring	1
D144	Y-Seal	1
D145	Spring Pin	1
D146	Steel Ball	1
D147	Piston Rod	1
D148	Dust Ring	1
D149	Fluid Fill Plug	1
D150	Shaft	1
D151	Handle Bracket	1
D152	Pressure Roller	1
D153	Handle Bracket Shaft	1
D154	Spring Pin	1
D155	Spring Pin	1
D156	Bushing	1
D157	Seal Washer	1
D158	Bushing	2

Record Product's Serial Number Here: \_\_\_\_\_

**Note:** If product has no serial number, record month and year of purchase instead.

**Note:** Some parts are listed and shown for illustration purposes only, and are not available individually as replacement parts. Specify UPC 193175436566 when ordering parts.

# Pump Diagram

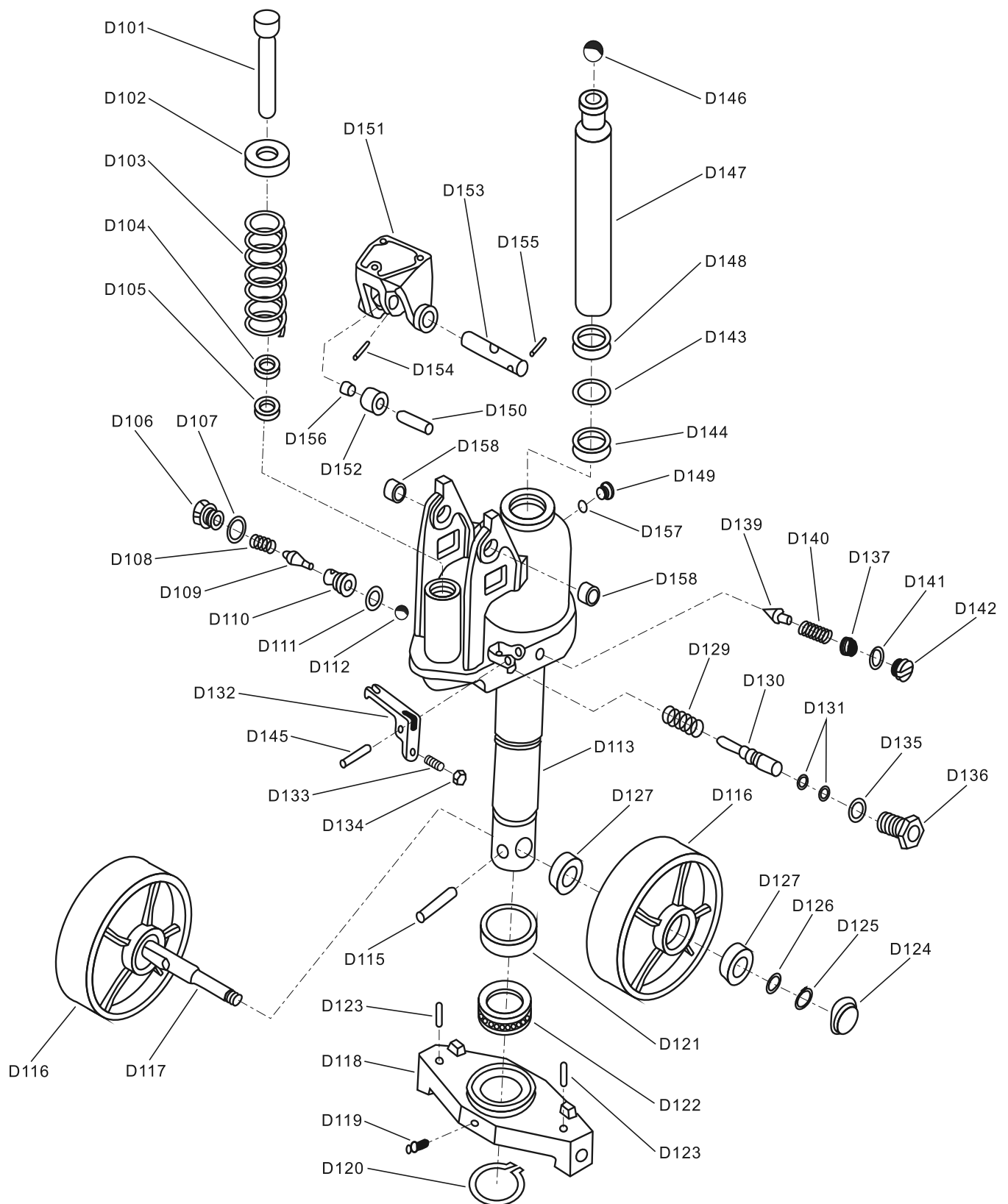

SAFETY

SETUP

OPERATION

MAINTENANCE

## Limited 90 Day Warranty

Harbor Freight Tools Co. makes every effort to assure that its products meet high quality and durability standards, and warrants to the original purchaser that this product is free from defects in materials and workmanship for the period of 90 days from the date of purchase. This warranty does not apply to damage due directly or indirectly, to misuse, abuse, negligence or accidents, repairs or alterations outside our facilities, criminal activity, improper installation, normal wear and tear, or to lack of maintenance. We shall in no event be liable for death, injuries to persons or property, or for incidental, contingent, special or consequential damages arising from the use of our product. Some states do not allow the exclusion or limitation of incidental or consequential damages, so the above limitation of exclusion may not apply to you. THIS WARRANTY IS EXPRESSLY IN LIEU OF ALL OTHER WARRANTIES, EXPRESS OR IMPLIED, INCLUDING THE WARRANTIES OF MERCHANTABILITY AND FITNESS.

To take advantage of this warranty, the product or part must be returned to us with transportation charges prepaid. Proof of purchase date and an explanation of the complaint must accompany the merchandise. If our inspection verifies the defect, we will either repair or replace the product at our election or we may elect to refund the purchase price if we cannot readily and quickly provide you with a replacement. We will return repaired products at our expense, but if we determine there is no defect, or that the defect resulted from causes not within the scope of our warranty, then you must bear the cost of returning the product.

This warranty gives you specific legal rights and you may also have other rights which vary from state to state.

26541 Agoura Road • Calabasas, CA 91302 • 1-888-866-5797

