

Owner's Manual & Safety Instructions

Save This Manual Keep this manual for the safety warnings and precautions, assembly, operating, inspection, maintenance and cleaning procedures. Write the product's serial number in the back of the manual near the assembly diagram (or month and year of purchase if product has no number). Keep this manual and the receipt in a safe and dry place for future reference.

20j



58323

INDUSTRIAL SERVICE CART



Visit our website at: <http://www.harborfreight.com>
Email our technical support at: productsupport@harborfreight.com

When unpacking, make sure that the product is intact and undamaged. If any parts are missing or broken, please call 1-888-866-5797 as soon as possible.

Copyright© 2017 by Harbor Freight Tools®. All rights reserved.
No portion of this manual or any artwork contained herein may be reproduced in any shape or form without the express written consent of Harbor Freight Tools. Diagrams within this manual may not be drawn proportionally. Due to continuing improvements, actual product may differ slightly from the product described herein.
Tools required for assembly and service may not be included.

⚠ WARNING

Read this material before using this product.
Failure to do so can result in serious injury.
SAVE THIS MANUAL.

Specifications

Maximum Capacity	500 lb.
Tray Size	24" L x 36" W x 3" Deep
Casters	2 fixed and 2 swivel, 5" diameter x 1" Wide

IMPORTANT SAFETY INFORMATION

READ ALL INSTRUCTIONS BEFORE USING THIS PRODUCT!

Safety Warnings and Precautions

WARNING: When using product, basic safety precautions should always be followed to reduce the risk of personal injury and damage to equipment.

Read all instructions before using this product!

- 1. Keep work area clean.** Cluttered areas invite injuries.
- 2. Observe work area conditions.** Keep work area well lighted.
- 3. Store idle equipment.** When not in use, the Service Cart must be stored in a safe and clean location. Always lock up products and keep out of reach of children.
- 4. Use the right product for the job.** There are certain applications for which the Service Cart was designed. Do not modify the Service Cart and do not use the Service Cart for a purpose for which it was not intended.
- 5. Check for damaged parts.** Before using any product, any part that appears damaged should be carefully checked to determine that it will operate properly and perform its intended function. Check for any broken or damaged parts and any other conditions that may affect its operation. Replace or repair damaged or worn parts immediately.
- 6. Replacement parts and accessories.** When servicing, use only identical replacement parts. Use of any other parts will void the warranty.
- 7. Do not operate product if under the influence of alcohol or drugs.** Read warning labels on prescriptions to determine if your judgment or reflexes are impaired while taking drugs. If there is any doubt, do not operate the product.
- 8. Use eye protection.** Always wear ANSI-approved impact safety goggles.
- 9. Do not exceed the product's maximum load capacity of 500 lb.**
- 10. Only use on a flat surface capable of supporting the Service Cart and its maximum capacity load of 500 lb.** It is easy to lose control of the Service Cart if attempting to pull a load on a sloping or uneven surface.
- 11. Do not allow children to play on, stand upon or climb on the Service Cart.** The Service Cart is not for carrying people or animals.
- 12. Always check hardware and assembled parts after assembling.** All connections should be tight and hardware tightened.
- 13. Always distribute objects in the Service Cart evenly.** Uneven weight distribution could cause tipping. Do not lean or climb on the Service Cart.

Assembly Instructions



Read the **ENTIRE IMPORTANT SAFETY INFORMATION** section at the beginning of this document including all text under subheadings therein before set up or use of this product.

1. Place one Table Board (3) upside down on the work surface. Locate the Handle (5). Turn it upside down with the cup holder toward the Table Board (3) and the hand holes on the outside. Using a rubber mallet, tap the Handle (5) down into the grooves on the Table Board (3) - see Assembly diagram.

2. Locate the two Legs (7). Place one on the Table Board (3) corner nearest the Handle (5), and place one on the diagonal corner located on the outside of the Table Board (3) as in the Assembly diagram. Make certain that the end with the screw holes is facing upward. Using a rubber mallet, tap the Legs (7) down into the Table Board (3).

Note: Position the Legs so that the flange in each matches the space in the Table Board (3).

3. Locate the two Legs (8). Place one on the Table Board (3) corner nearest the Handle (5), and place one on the diagonal corner located on the outside of the Table Board (3) as in the Assembly diagram. Make certain that the end with the screw holes is facing upward. Using a rubber mallet, tap the Legs (8) down into the Table Board (3).

4. Insert Bolts (4) down through the Table Board (3) and into each Leg (7) and Leg (8) - see Assembly diagram step 3.

5. Locate the second Table Board and turn it upside down. Set the second Table Board (3) onto the Legs (7 & 8) making certain that both Table Boards (3) are facing the same way.

6. Turn the Service Cart right-side up. Set the Covers (1 and 2) down onto each corner of the top Table Board (3) - see Assembly diagram step 4.

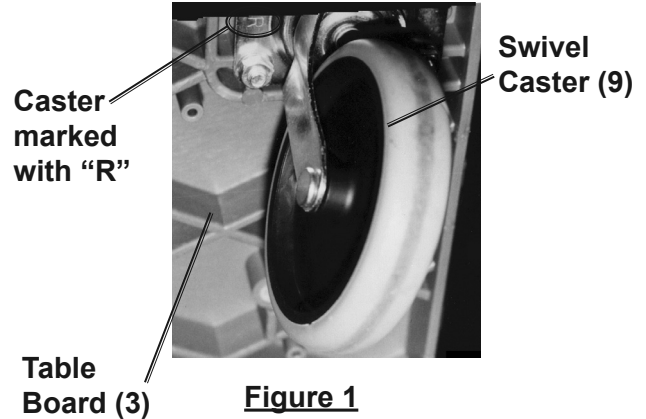

7. Turn the Service Cart upside down again. As necessary, attach one Wheel (11) to each of the two Swivel Casters (9) using one Bolt (12) and secured in place with Nut (10) - see Figure 1 and Assembly diagram step 5.

8. As necessary, attach one Wheel (11) to each of the two Fixed Casters (13) with Bolt (12), and Nut (10).

9. Place the two Casters marked "R" on the same side of the Table Board as the Handle (5)- see Figure 1 and Assembly diagram step 4.

10. Thread Bolts (17) down through the Table Board (3) and into the Casters (9 and 13). Slide on Split Washer (14) and thread on Nuts (16).

11. Turn the Service Cart upright. Make certain that all hardware is tight. Make certain that the Fixed Casters (13) and Swivel Casters (9) roll properly.

PLEASE READ THE FOLLOWING CAREFULLY

THE MANUFACTURER AND/OR DISTRIBUTOR HAS PROVIDED THE PARTS LIST AND ASSEMBLY DIAGRAM IN THIS DOCUMENT AS A REFERENCE TOOL ONLY. NEITHER THE MANUFACTURER OR DISTRIBUTOR MAKES ANY REPRESENTATION OR WARRANTY OF ANY KIND TO THE BUYER THAT HE OR SHE IS QUALIFIED TO MAKE ANY REPAIRS TO THE PRODUCT, OR THAT HE OR SHE IS QUALIFIED TO REPLACE ANY PARTS OF THE PRODUCT. IN FACT, THE MANUFACTURER AND/OR DISTRIBUTOR EXPRESSLY STATES THAT ALL REPAIRS AND PARTS REPLACEMENTS SHOULD BE UNDERTAKEN BY CERTIFIED AND LICENSED TECHNICIANS, AND NOT BY THE BUYER. THE BUYER ASSUMES ALL RISK AND LIABILITY ARISING OUT OF HIS OR HER REPAIRS TO THE ORIGINAL PRODUCT OR REPLACEMENT PARTS THERETO, OR ARISING OUT OF HIS OR HER INSTALLATION OF REPLACEMENT PARTS THERETO.

Parts List and Diagram

Part	Description	Qty
1	Cover	2
2	Cover	2
3	Table Board	2
4	Screw	12
5	Handle	1
7	Leg	2
8	Leg	2
9	Swivel Caster	2
10	Nut	4
11	Wheel	4
12	Bolt	4
13	Fixed Caster	2
14	Split Washer	16
16	Nut	16
17	Bolt	16
18	Rod	1

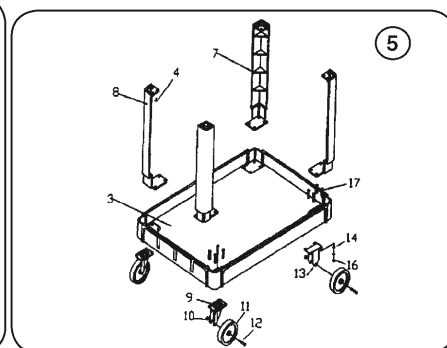
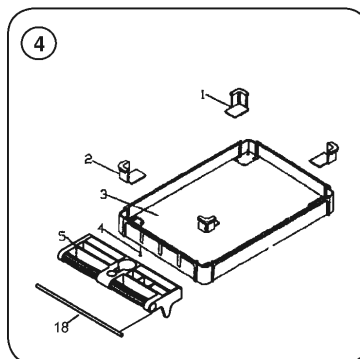
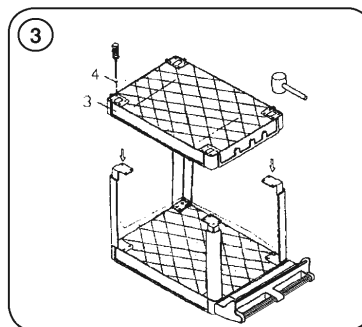
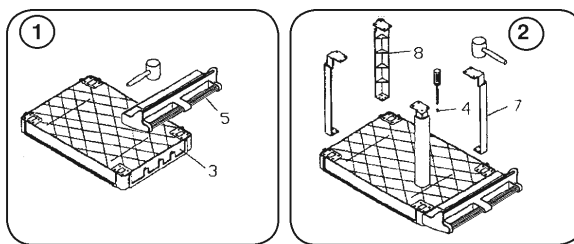

Record Serial Number Here:

Note: If product has no serial number, record month and year of purchase instead.

Note: Some parts are listed and shown for illustration purposes only, and are not available individually as replacement parts. Specify UPC 193175437358 when ordering parts.

Limited 90 Day Warranty

Harbor Freight Tools Co. makes every effort to assure that its products meet high quality and durability standards, and warrants to the original purchaser that this product is free from defects in materials and workmanship for the period of 90 days from the date of purchase. This warranty does not apply to damage due directly or indirectly, to misuse, abuse, negligence or accidents, repairs or alterations outside our facilities, criminal activity, improper installation, normal wear and tear, or to lack of maintenance. We shall in no event be liable for death, injuries to persons or property, or for incidental, contingent, special or consequential damages arising from the use of our product. Some states do not allow the exclusion or limitation of incidental or consequential damages, so the above limitation of exclusion may not apply to you. THIS WARRANTY IS EXPRESSLY IN LIEU OF ALL OTHER WARRANTIES, EXPRESS OR IMPLIED, INCLUDING THE WARRANTIES OF MERCHANTABILITY AND FITNESS.

To take advantage of this warranty, the product or part must be returned to us with transportation charges prepaid. Proof of purchase date and an explanation of the complaint must accompany the merchandise. If our inspection verifies the defect, we will either repair or replace the product at our election or we may elect to refund the purchase price if we cannot readily and quickly provide you with a replacement. We will return repaired products at our expense, but if we determine there is no defect, or that the defect resulted from causes not within the scope of our warranty, then you must bear the cost of returning the product.

This warranty gives you specific legal rights and you may also have other rights which vary from state to state.

