

Owner's Manual & Safety Instructions

Save This Manual Keep this manual for the safety warnings and precautions, assembly, operating, inspection, maintenance and cleaning procedures. Write the product's serial number in the back of the manual near the assembly diagram (or month and year of purchase if product has no number). Keep this manual and the receipt in a safe and dry place for future reference.

22d



DIAMONDBACK®

TILE SAW STAND



Tile Saw sold
separately

Visit our website at: <http://www.harborfreight.com>
Email our technical support at: productsupport@harborfreight.com

58477

When unpacking, make sure that the product is intact and undamaged. If any parts are missing or broken, please call 1-888-866-5797 as soon as possible.

Copyright© 2021 by Harbor Freight Tools®. All rights reserved.

No portion of this manual or any artwork contained herein may be reproduced in any shape or form without the express written consent of Harbor Freight Tools. Diagrams within this manual may not be drawn proportionally. Due to continuing improvements, actual product may differ slightly from the product described herein. Tools required for assembly and service may not be included.

⚠WARNING

Read this material before using this product. Failure to do so can result in serious injury. **SAVE THIS MANUAL.**

Important Safety Information

Assembly Precautions

1. Assemble only according to these instructions. Improper assembly can create hazards.
2. Wear ANSI-approved safety goggles and heavy-duty work gloves during assembly.
3. Keep assembly area clean and well lit.
4. Keep bystanders out of the area during assembly.
5. Do not assemble when tired or when under the influence of drugs or medication.

Use Precautions

1. Follow all warnings and instructions in the Tile Saw's manual that this Stand is used with.
2. Use only on level, flat, hard surface able to support weight of stand, saw, and workpiece.
3. This product is not a toy. Do not allow children to play with or near this item.
4. Use as intended only. Use with 7" and 10" Diamondback Tile Saws only.
5. **Turn the Power Switch of the tile saw to its "OFF" position, remove its key, and unplug the tool from its electrical outlet before mounting to stand.**
6. Inspect before every use; do not use if parts are loose or damaged.
7. Maintain product labels and nameplates. These carry important safety information. If unreadable or missing, contact Harbor Freight Tools for a replacement.

Assembly Instructions



Read the ENTIRE IMPORTANT SAFETY INFORMATION section at the beginning of this document including all text under subheadings therein before set up or use of this product.

Note: Tile Saw sold separately.

1. Slide a Lock Washer (10), Wheel (7), Flat Washer (9) and Lock Nut (8) onto the Axle. Tighten securely. Repeat with other Wheel.

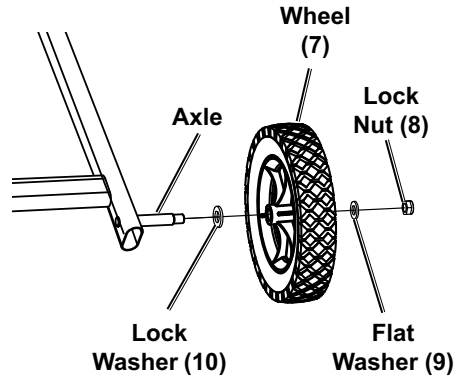

Mounting Instructions

Mounting 10" Saw to Stand

WARNING! TO PREVENT SERIOUS INJURY: Turn the Power Switch of the tile saw to its "OFF" position, remove its key, and unplug the tool from its electrical outlet before mounting to stand.

1. Lock the Toggle Table Stop by pulling up on it and turning it until the slot in the center of the Stop is horizontal (left to right).
2. Pull the Table to the front of the Frame. From under the right side of the Table, align the hole in the rail with the pin in the Table Lock Lever. Push the pin into the rail, locking the Table.

3. With assistance, place Saw on Stand. Align the holes on the Water Tray Frame with the holes on the Stand.
4. Secure Saw to Stand with two Washers M8 (3) and two Bolts M8x20 (4), tighten Bolts securely.

WARNING! TO PREVENT SERIOUS INJURY: If the Saw does not mount securely and completely to this Stand, do not use it with this Stand.

Power Switch
& Key

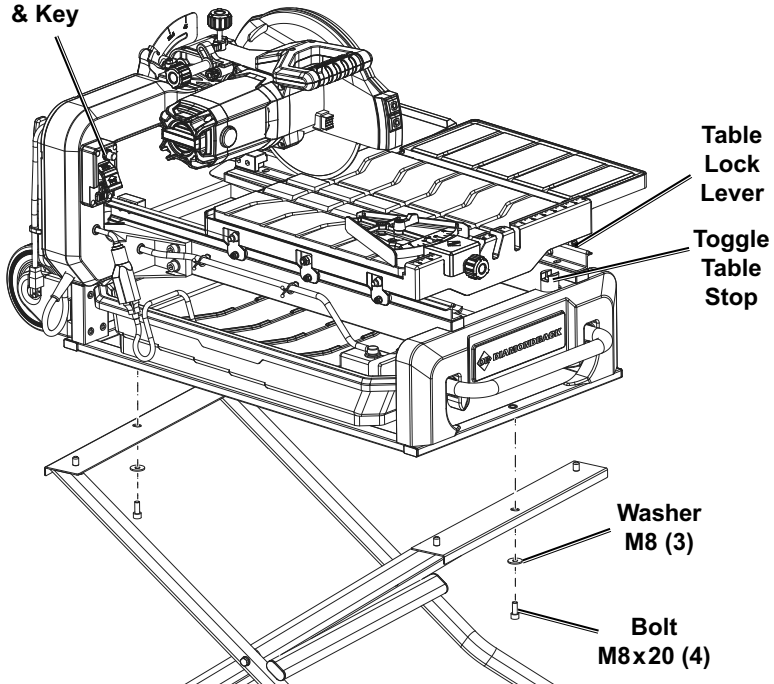

Mounting 7" Saw to Stand

WARNING! TO PREVENT SERIOUS INJURY: Turn the Power Switch of the tile saw to its "OFF" position, remove its key, and unplug the tool from its electrical outlet before mounting to stand.

1. Lock the Toggle Table Stop by pulling up on it and turning it until the slot in the center of the Stop is horizontal (left to right).
2. Pull the Table to the front of the Frame. From under the right side of the Table, align the hole in the rail with the pin in the Table Lock Lever. Push the pin into the rail, locking the Table.
3. Attach two Stand Brackets, from Tile Saw hardware, to ends of Water Tray using two ST4.8x13 Screws, from Tile Saw hardware, per Bracket.
4. With assistance, place Saw on Stand. Align the holes on the Water Tray Frame with the holes on the Stand.
5. Secure Stand Brackets to Stand with two Bolts M8x20 (4), two Washers M8 (3), two Flat Washers M10 (9), and two Lock Nuts M8 (12). Tighten Lock Nuts securely.

WARNING! TO PREVENT SERIOUS INJURY: If the Saw does not mount securely and completely to this Stand, do not use it with this Stand.

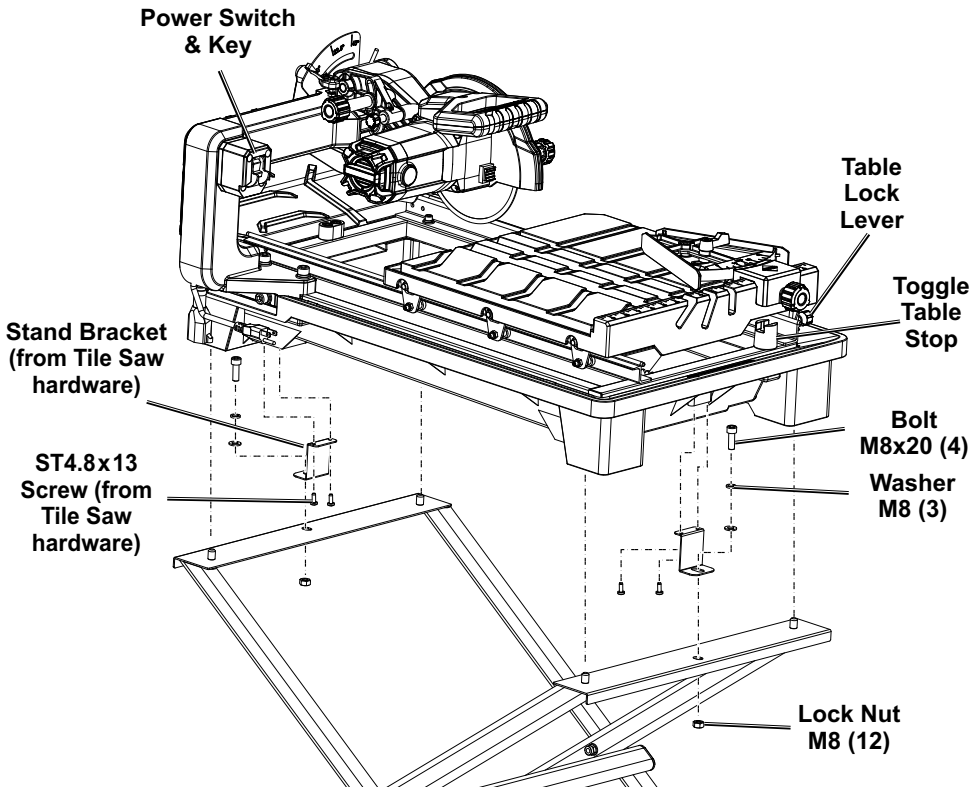

PLEASE READ THE FOLLOWING CAREFULLY

THE MANUFACTURER AND/OR DISTRIBUTOR HAS PROVIDED THE PARTS LIST AND ASSEMBLY DIAGRAM IN THIS DOCUMENT AS A REFERENCE TOOL ONLY. NEITHER THE MANUFACTURER OR DISTRIBUTOR MAKES ANY REPRESENTATION OR WARRANTY OF ANY KIND TO THE BUYER THAT HE OR SHE IS QUALIFIED TO MAKE ANY REPAIRS TO THE PRODUCT, OR THAT HE OR SHE IS QUALIFIED TO REPLACE ANY PARTS OF THE PRODUCT. IN FACT, THE MANUFACTURER AND/OR DISTRIBUTOR EXPRESSLY STATES THAT ALL REPAIRS AND PARTS REPLACEMENTS SHOULD BE UNDERTAKEN BY CERTIFIED AND LICENSED TECHNICIANS, AND NOT BY THE BUYER. THE BUYER ASSUMES ALL RISK AND LIABILITY ARISING OUT OF HIS OR HER REPAIRS TO THE ORIGINAL PRODUCT OR REPLACEMENT PARTS THERETO, OR ARISING OUT OF HIS OR HER INSTALLATION OF REPLACEMENT PARTS THERETO.

Parts List

Part	Description	Qty
1	Hex Bolt M8x55	2
2	Insert	2
3	Flat Washer M8	6
4	Hex Socket Bolt M8x20	2
5	Front Support Leg	1
6	Feet	2
7	Wheel	2
8	Locknut M10	2
9	Flat Washer M10	2
10	Lock Washer M12	2
11	Rear Support Leg	1
12	Locknut M8	4

Record Serial Number Here: _____

Note: If product has no serial number, record month and year of purchase instead.

Note: Some parts are listed and shown for illustration purposes only, and are not available individually as replacement parts. Specify UPC 193175440068 when ordering parts.

Assembly Diagram

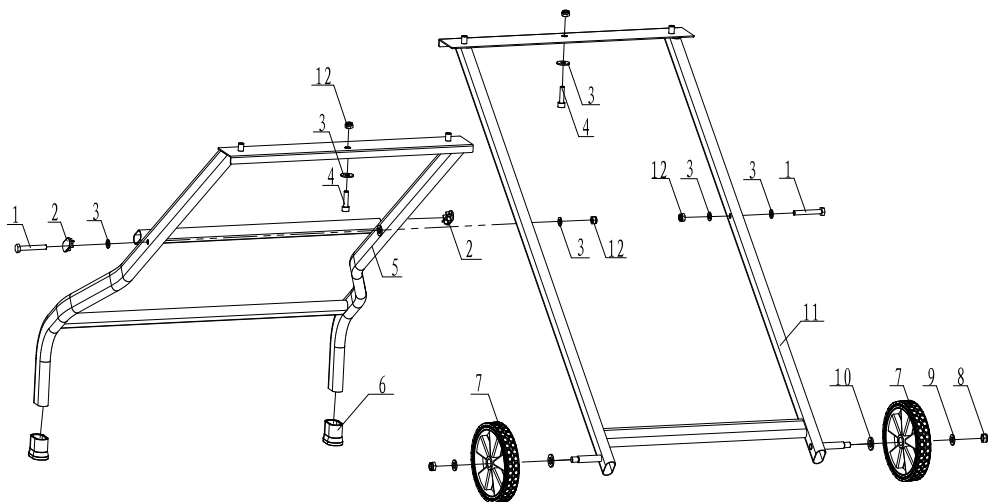

Limited 90 Day Warranty

Harbor Freight Tools Co. makes every effort to assure that its products meet high quality and durability standards, and warrants to the original purchaser that this product is free from defects in materials and workmanship for the period of 90 days from the date of purchase. This warranty does not apply to damage due directly or indirectly, to misuse, abuse, negligence or accidents, repairs or alterations outside our facilities, criminal activity, improper installation, normal wear and tear, or to lack of maintenance. We shall in no event be liable for death, injuries to persons or property, or for incidental, contingent, special or consequential damages arising from the use of our product. Some states do not allow the exclusion or limitation of incidental or consequential damages, so the above limitation of exclusion may not apply to you. THIS WARRANTY IS EXPRESSLY IN LIEU OF ALL OTHER WARRANTIES, EXPRESS OR IMPLIED, INCLUDING THE WARRANTIES OF MERCHANTABILITY AND FITNESS.

To take advantage of this warranty, the product or part must be returned to us with transportation charges prepaid. Proof of purchase date and an explanation of the complaint must accompany the merchandise. If our inspection verifies the defect, we will either repair or replace the product at our election or we may elect to refund the purchase price if we cannot readily and quickly provide you with a replacement. We will return repaired products at our expense, but if we determine there is no defect, or that the defect resulted from causes not within the scope of our warranty, then you must bear the cost of returning the product.

This warranty gives you specific legal rights and you may also have other rights which vary from state to state.

