

Owner's Manual & Safety Instructions

Save This Manual Keep this manual for the safety warnings and precautions, assembly, operating, inspection, maintenance and cleaning procedures. Write the product's serial number in the back of the manual near the assembly diagram (or month and year of purchase if product has no number). Keep this manual and the receipt in a safe and dry place for future reference.

21j

BauerTM

21506C-B

20v

HYPERMAXTM LITHIUM



**For Best Results,
Use 3.0 Amp Hour Battery
(Sold Separately)**

VARIABLE SPEED GREASE GUN

Visit our website at: <http://www.harborfreight.com>
Email our technical support at: productsupport@harborfreight.com

58608

When unpacking, make sure that the product is intact and undamaged. If any parts are missing or broken, please call 1-888-866-5797 as soon as possible.

Copyright© 2021 by Harbor Freight Tools®. All rights reserved.
No portion of this manual or any artwork contained herein may be reproduced in any shape or form without the express written consent of Harbor Freight Tools. Diagrams within this manual may not be drawn proportionally. Due to continuing improvements, actual product may differ slightly from the product described herein.
Tools required for assembly and service may not be included.

⚠WARNING

Read this material before using this product.
Failure to do so can result in serious injury.
SAVE THIS MANUAL.

Table of Contents

Safety	2	Maintenance	11
Specifications	6	Parts List and Diagram	12
Setup	6	Warranty	15
Operation.....	8		



SAFETY

SETUP

OPERATION

MAINTENANCE

WARNING SYMBOLS AND DEFINITIONS

	This is the safety alert symbol. It is used to alert you to potential personal injury hazards. Obey all safety messages that follow this symbol to avoid possible injury or death.
	Indicates a hazardous situation which, if not avoided, will result in death or serious injury.
	Indicates a hazardous situation which, if not avoided, could result in death or serious injury.
	Indicates a hazardous situation which, if not avoided, could result in minor or moderate injury.
	Addresses practices not related to personal injury.

IMPORTANT SAFETY INFORMATION

General Power Tool Safety Warnings

WARNING

Read all safety warnings, instructions, illustrations and specifications provided with this power tool. Failure to follow all instructions listed below may result in electric shock, fire and/or serious injury.

Save all warnings and instructions for future reference.

The term "power tool" in the warnings refers to your mains-operated (corded) power tool or battery-operated (cordless) power tool.

1. **Work area safety**
 - a. **Keep work area clean and well lit.**
Cluttered or dark areas invite accidents.
 - b. **Do not operate power tools in explosive atmospheres, such as in the presence of flammable liquids, gases or dust.** *Power tools create sparks which may ignite the dust or fumes.*
 - c. **Keep children and bystanders away while operating a power tool.** *Distractions can cause you to lose control.*

2. Electrical safety

- a. **Power tool plugs must match the outlet. Never modify the plug in any way. Do not use any adapter plugs with earthed (grounded) power tools. Unmodified plugs and matching outlets will reduce risk of electric shock.**
- b. **Avoid body contact with earthed or grounded surfaces, such as pipes, radiators, ranges and refrigerators.** *There is an increased risk of electric shock if your body is earthed or grounded.*
- c. **Do not expose power tools to rain or wet conditions.** *Water entering a power tool will increase the risk of electric shock.*
- d. **Do not abuse the cord. Never use the cord for carrying, pulling or unplugging the power tool. Keep cord away from heat, oil, sharp edges or moving parts. Damaged or entangled cords increase the risk of electric shock.**
- e. **When operating a power tool outdoors, use an extension cord suitable for outdoor use.** *Use of a cord suitable for outdoor use reduces the risk of electric shock.*
- f. **If operating a power tool in a damp location is unavoidable, use a ground fault circuit interrupter (GFCI) protected supply.** *Use of a GFCI reduces the risk of electric shock.*
- e. **Prevent unintentional starting. Ensure the switch is in the off-position before connecting to power source and/or battery pack, picking up or carrying the tool.** *Carrying power tools with your finger on the switch or energizing power tools that have the switch on invites accidents.*
- f. **Remove any adjusting key or wrench before turning the power tool on.** *A wrench or a key left attached to a rotating part of the power tool may result in personal injury.*
- g. **Do not overreach. Keep proper footing and balance at all times.** *This enables better control of the power tool in unexpected situations.*
- h. **Dress properly. Do not wear loose clothing or jewelry. Keep your hair, clothing and gloves away from moving parts.** *Loose clothes, jewelry or long hair can be caught in moving parts.*
- i. **If devices are provided for the connection of dust extraction and collection facilities, ensure these are connected and properly used.** *Use of dust collection can reduce dust-related hazards.*
- j. **Do not let familiarity gained from frequent use of tools allow you to become complacent and ignore tool safety principles.** *A careless action can cause severe injury within a fraction of a second.*

3. Personal safety

- a.  **INJECTION HAZARD!** **Hold the end of the hose by the spring guard only. Keep hands away from exposed rubber part of hose.** *Through improper use, grease can be injected through a person's skin, leading to serious injury, possibly amputation. If grease is accidentally injected into someone's skin, contact a doctor immediately. Do not treat an injection injury as a simple cut. Injection can lead to amputation and requires immediate surgical treatment.*
- b. **Stay alert, watch what you are doing and use common sense when operating a power tool. Do not use a power tool while you are tired or under the influence of drugs, alcohol or medication.** *A moment of inattention while operating power tools may result in serious personal injury.*
- c. **Do not stare at operating lamp.**
- d. **Use personal protective equipment. Always wear eye protection.** *Protective equipment such as dust mask, non-skid safety shoes, hard hat, heavy-duty work gloves, or hearing protection used for appropriate conditions will reduce personal injuries.*
- k. Only use safety equipment that has been approved by an appropriate standards agency. Unapproved safety equipment may not provide adequate protection. Eye protection must be ANSI-approved and breathing protection must be NIOSH-approved for the specific hazards in the work area.
- l. Do not leave the tool unattended when the Battery Pack is connected. Turn off the tool, and remove the Battery Pack before leaving.
- m. This product is not a toy. Keep it out of reach of children.
- n. People with pacemakers should consult their physician(s) before use. Electromagnetic fields in close proximity to heart pacemaker could cause pacemaker interference or pacemaker failure.
- o. The warnings, precautions, and instructions discussed in this instruction manual cannot cover all possible conditions and situations that may occur. It must be understood by the operator that common sense and caution are factors which cannot be built into this product, but must be supplied by the operator.

4. Power tool use and care

- a. **Do not force the power tool. Use the correct power tool for your application.** *The correct power tool will do the job better and safer at the rate for which it was designed.*
- b. **Do not use the power tool if the switch does not turn it on and off.** *Any power tool that cannot be controlled with the switch is dangerous and must be repaired.*
- c. **Disconnect the plug from the power source and/or remove the battery pack, if detachable, from the power tool before making any adjustments, changing accessories, or storing power tools.** *Such preventive safety measures reduce the risk of starting the power tool accidentally.*
- d. **Store idle power tools out of the reach of children and do not allow persons unfamiliar with the power tool or these instructions to operate the power tool.** *Power tools are dangerous in the hands of untrained users.*
- e. **Maintain power tools and accessories.** **Check for misalignment or binding of moving parts, breakage of parts and any other condition that may affect the power tool's operation. If damaged, have the power tool repaired before use.** *Many accidents are caused by poorly maintained power tools.*
- f. **Keep cutting tools sharp and clean.** *Properly maintained cutting tools with sharp cutting edges are less likely to bind and are easier to control.*
- g. **Use the power tool, accessories and tool bits etc. in accordance with these instructions, taking into account the working conditions and the work to be performed.** *Use of the power tool for operations different from those intended could result in a hazardous situation.*
- h. **Keep handles and grasping surfaces dry, clean and free from oil and grease.** *Slippery handles and grasping surfaces do not allow for safe handling and control of the tool in unexpected situations.*

5. Service

- a. **Have your power tool serviced by a qualified repair person using only identical replacement parts.** *This will ensure that the safety of the power tool is maintained.*
- b. **Never service damaged battery packs.** *Service of battery packs should only be performed by the manufacturer or authorized service providers.*
- c. **Maintain labels and nameplates on the tool.** *These carry important safety information. If unreadable or missing, contact Harbor Freight Tools for a replacement.*

6. Battery tool use and care

- a. **Prevent unintentional starting.** *Ensure the switch is in the off-position before connecting to battery pack, picking up or carrying the power tool. Carrying the power tool with your finger on the switch or energizing power tool that have the switch on invites accidents.*
- b. **Disconnect the battery pack from the power tool before making any adjustments, changing accessories, or storing power tool.** *Such preventive safety measures reduce the risk of starting the power tool accidentally.*
- c. **Recharge only with the charger specified by the manufacturer.** *A charger that is suitable for one type of battery pack may create a risk of fire when used with another battery pack.*
- d. **Use power tools only with specifically designated battery packs.** *Use of any other battery packs may create a risk of injury and fire.*
- e. **When battery pack is not in use, keep it away from other metal objects, like paper clips, coins, keys, nails, screws or other small metal objects, that can make a connection from one terminal to another.** *Shorting the battery terminals together may cause burns or a fire.*
- f. **Under abusive conditions, liquid may be ejected from the battery; avoid contact.** *If contact accidentally occurs, flush with water. If liquid contacts eyes, additionally seek medical help. Liquid ejected from the battery may cause irritation or burns.*
- g. **Do not use a battery pack or power tool that is damaged or modified.** *Damaged or modified batteries may exhibit unpredictable behavior resulting in fire, explosion or risk of injury.*
- h. **Do not expose a battery pack or power tool to fire or excessive temperature.** *Exposure to fire or temperature above 265°F may cause explosion.*
- i. **Follow all charging instructions and do not charge the battery pack or power tool outside of the temperature range specified in the instructions.** *Charging improperly or at temperatures outside of the specified range may damage the battery and increase the risk of fire.*
- j. **Have servicing performed by a qualified repair person using only identical replacement parts.** *This will ensure that the safety of the product is maintained.*
- k. **Do not modify or attempt to repair the power tool or the battery pack except as indicated in the instructions for use and care.**

- I.  The battery Charger gets hot during use. The Charger's heat can build up to unsafe levels and create a fire hazard if it does not receive adequate ventilation, due to an electrical fault, or if it is used in a hot environment. Do not place the Charger on a flammable surface. Do not obstruct any vents on the Charger. **Especially avoid placing the Charger on carpets and rugs; they are not only flammable, but they also obstruct vents under the Charger.** Place the Charger on a stable, solid, nonflammable surface (such as a stable metal workbench or concrete floor) at least 1 foot away from all flammable objects, such as drapes or walls. Keep a fire extinguisher and a smoke detector in the area. Frequently monitor the Charger and Battery Pack while charging.

7. Lithium Battery Safety Warnings



LITHIUM BATTERIES STORE A LARGE AMOUNT OF ENERGY AND WILL VENT FIRE OR EXPLODE IF MISTREATED:

- a. Keep Battery Pack dry.
- b. **DO NOT DO ANY OF THE FOLLOWING TO THE BATTERY PACK:**
 - Open,
 - Drop,
 - Short-circuit,
 - Puncture,
 - Incinerate, or
 - Expose to temperatures greater than 265°F.
- c. Charge Battery Pack only according to its Charger's instructions.
- d. Inspect Battery Pack before every use; do not use or charge if damaged.

Grounding

⚠️ WARNING









TO PREVENT ELECTRIC SHOCK AND DEATH FROM INCORRECT GROUNDING: Check with a qualified electrician if you are in doubt as to whether the outlet is properly grounded. Do not modify the power cord plug provided with the charger. Do not use the charger if the power cord or plug is damaged. If damaged, have it repaired by a service facility before use. If the plug will not fit the outlet, have a proper outlet installed by a qualified electrician.

Extension Cords

Note: Extension cords must not be used with this item's Charger.

Symbology

	Double Insulated
V	Volts
~	Alternating Current
A	Amperes
n ₀ xxxx/min.	No Load Revolutions per Minute (RPM)
	WARNING marking concerning Risk of Eye Injury. Wear ANSI-approved safety goggles with side shields.

	Read the manual before set-up and/or use.
	WARNING marking concerning Risk of Fire. Do not cover Charger ventilation ducts. Charge on fireproof surface only.
	WARNING marking concerning Risk of Electric Shock. Properly connect Charger's power cord to appropriate outlet.
	WARNING marking concerning Risk of Explosion. Do not puncture, short, or open battery packs and do not charge damaged battery packs.

Specifications

Battery Type	20V Bauer Li-ion (64816, 57007)
Charger Type	20V Bauer Li-ion (57006)
Maximum Pressure	10,000 PSI
Grease Cartridge Capacity	14.5 oz.
Maximum Flow Rate	5 oz/min.
Hose Outlet Threads (Tool)	7/16 UNEF
Hose Outlet Threads (Coupler Side)	1/8" NPT
Outlet Threads (Filler Port)	1/8" NPT
Hose Length	36"

Setup - Before Use:



Read the **ENTIRE IMPORTANT SAFETY INFORMATION** section at the beginning of this manual including all text under subheadings therein before set up or use of this product.

Note: For additional information regarding the parts listed in the following pages, refer to *Parts List and Diagram* on page 12.

Charging

Follow instructions included with the Charger, sold separately.

Functions

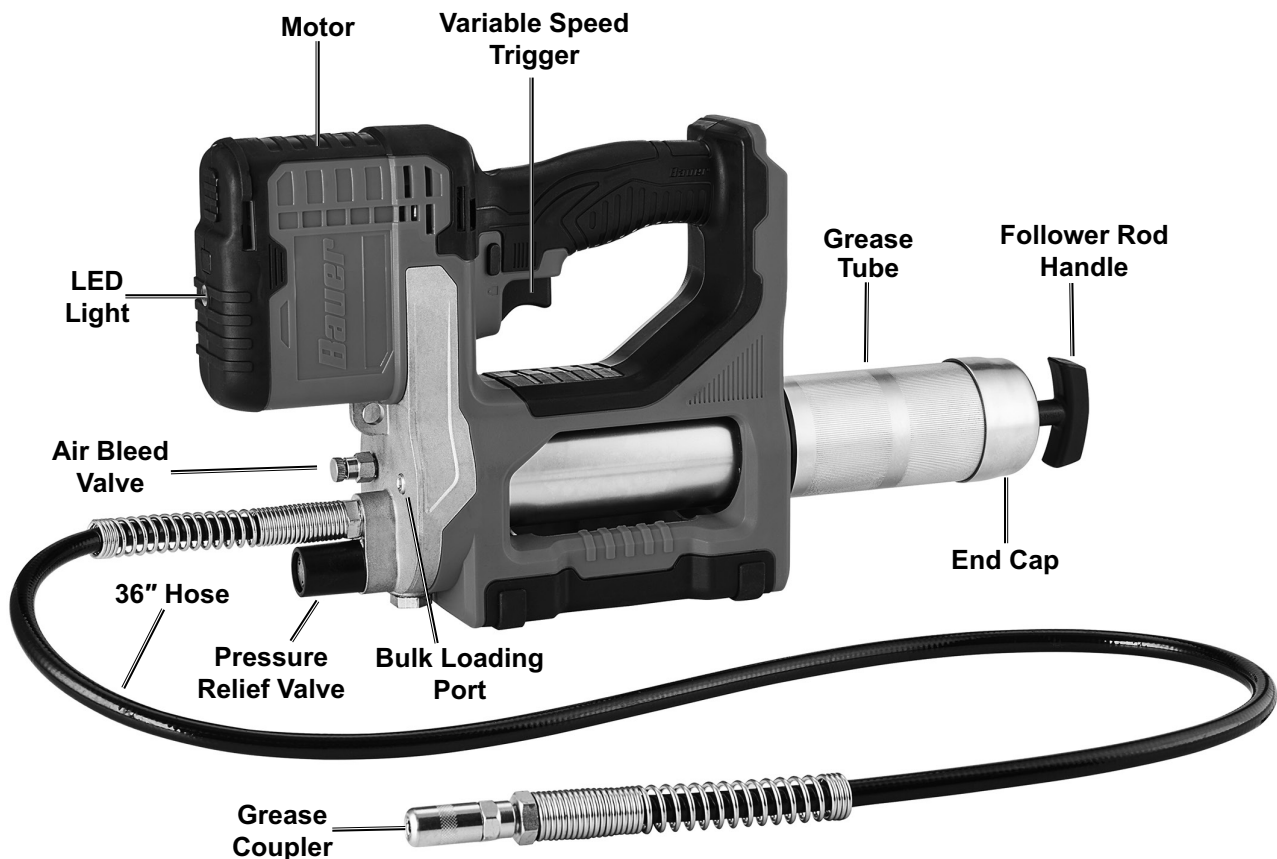

Variable Speed Trigger

The tool will produce a higher volume of grease as more force is placed on the Variable Speed Trigger. To unlock the Trigger for use, press Trigger Lock in from the left side of tool.

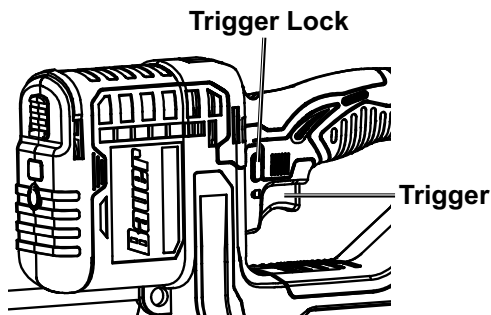

LED Light

The LED light is activated by pulling the Trigger and will automatically shut off after 20 seconds of use. The light can be turned off manually by pressing the LED Power Button.

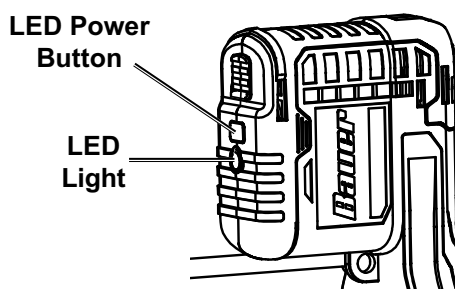

Pressure Relief Valve

If maximum PSI is exceeded, grease will come out of the Pressure Relief Valve, indicating a line blockage. If tool continues to run while blocked, the motor will overload and tool will stall. To clear blockage, see *Clearing Contaminants* section on page 9.

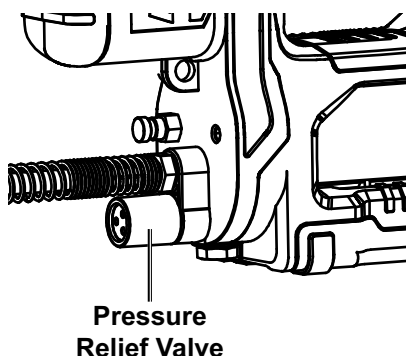

Shoulder Strap

The Shoulder Strap will connect to the tool at two points:

- The strap mounting hole located beside the Air Bleed Valve.
- A retractable hook located at the back end of the motor. The retractable hook must be pulled out manually for use.

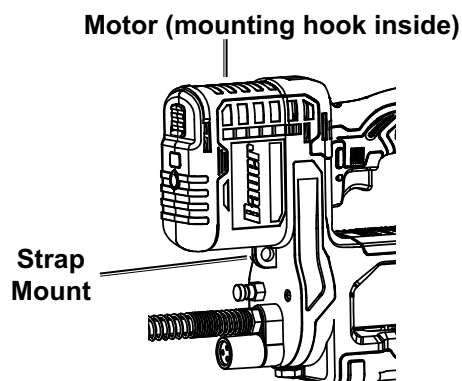

Operating Instructions



Read the **ENTIRE IMPORTANT SAFETY INFORMATION** section at the beginning of this manual including all text under subheadings therein before set up or use of this product.

Work Area Set Up

1. Designate a work area that is clean and well lit. The work area must not allow access by children or pets to prevent distraction and injury.
2. There must not be objects, such as utility lines, nearby that will present a hazard while working.

Setting and Testing

⚠️ WARNING

TO PREVENT SERIOUS INJURY FROM ACCIDENTAL OPERATION: Make sure that the Trigger is locked and Battery Pack is removed before performing any procedure in this section.

Loading the Grease Gun with a Grease Cartridge

1. Pull back on Follower Rod Handle until the Follower Rod is fully extended. Pull Follower Rod sideways to latch it into the slot on the End Cap of the Grease Tube, locking it open.
2. Unscrew and remove Grease Tube from Grease Gun Head Assembly.
3. Remove the cap from a grease cartridge (not included), and insert the cartridge into Grease Tube.
4. Remove the pull tab from the grease cartridge and screw the Grease Tube back into the Head Assembly.
5. Open Air Bleed Valve.
6. Release Follower Rod from the slot on the End Cap to allow the Follower Rod to move forward into the Grease Tube.

Loading the Grease Gun from a Bulk Container

1. Unscrew and remove the Grease Tube from the Grease Gun Head Assembly.
2. Insert the open end of Grease Tube into lubricant. Slowly pull the Follower Rod back while pushing the Grease Tube deeper into the lubricant to prevent air pockets from being pulled into the Grease Tube.
3. When the Follower Rod is fully extended, pull it sideways to latch the Rod into the slot on the End Cap of the Grease Tube, locking it open.
4. Screw the Grease Tube into the Head Assembly.
5. Release the Follower Rod from the slot on the End Cap of the Grease Tube to allow the Follower Rod to move forward into the Grease Tube.
6. Clean any excess grease off the outer body of the Grease Gun.

Loading the Grease Gun with a Filler Pump

1. Pull back on the Follower Rod Handle until the Follower Rod is fully extended.
2. Remove plug on Bulk Loading Port.
3. Place bulk filler nipple (sold separately) on the Port and insert into the socket of filler pump (sold separately). Verify socket is fastened securely to Valve.
4. Operate the filler pump until the Grease Tube is filled.
5. Disconnect the bulk filler nipple from the socket on the filler pump.
6. Move the Follower Rod forward into the Grease Tube.

Clearing Contaminants

Note: Contaminants can be pulled into the tool and clog the valve. See *Troubleshooting* section on page 11 for contamination causes. To clear any contamination:

Hose Removal:

1. Remove the Hose Assembly.
2. Pull Trigger for 45 seconds. If grease begins to flow then the contamination has been cleared.
3. Replace Hose Assembly and operate the tool.

Check Valve:

1. Locate the Check Valve that sits below the Pressure Relief Valve.

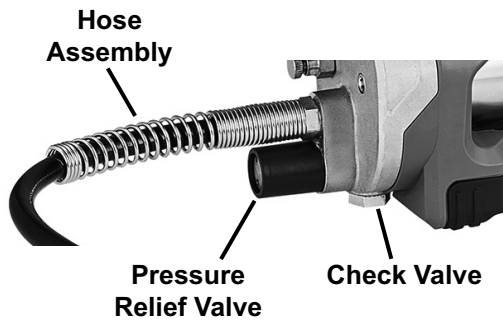

2. Remove the Bolt and Washer from the Check Valve and pull Trigger for 15 seconds.
3. If a Spring and Ball are expelled from the Check Valve, clean both parts with a clean cloth.
4. Inspect the open Check Valve for any contaminants. If found, run Grease Gun to flush out contaminants.
5. Replace the Ball, Spring, Washer, and Bolt in order shown, securing tightly.

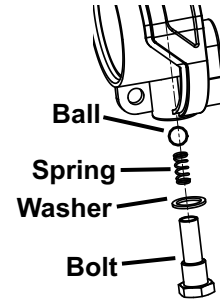

6. Pull Trigger for 30 seconds and operate the tool.

General Instructions for Use

SAFETY

⚠️WARNING

TO PREVENT SERIOUS INJURY FROM INJECTION: Wear ANSI-approved eye protection and heavy-duty work gloves during use.

1. Make sure that the Trigger is in the off-position, then attach the Battery Pack.
2. Prime Gun by simultaneously squeezing the Trigger and opening the Air Bleed Valve to expel any air pockets.
3. If grease will not flow, then air pockets likely remain:
 - a. Pull back on the Follower Rod Handle until the Follower Rod is fully extended.
 - b. Open Air Bleed Valve and pull Trigger repeatedly to pump grease through the Valve.
 - c. Push Follower Rod back into Grease Tube.
4. Clean the grease zerk fitting of the object to be lubricated carefully and completely with a clean cloth prior to attaching the Grease Gun's Coupler onto the zerk fitting.
5. Attach the Coupler by pressing it straight onto the clean grease zerk fitting. Make sure that the Coupler is fully seated on the zerk fitting.
6. Squeeze the Trigger several times or until a small amount of grease begins to flow out of the greased bushing.
7. When greasing is complete, lock Trigger Lock, then tilt Coupler, twist nozzle of grease gun, and pull back to remove from zerk fitting. (See below.) Wipe any excess grease from exterior of the grease fitting and Coupler.
8. To prevent accidents, turn off the tool and remove its Battery Pack after use. Clean, then store the tool indoors out of children's reach.

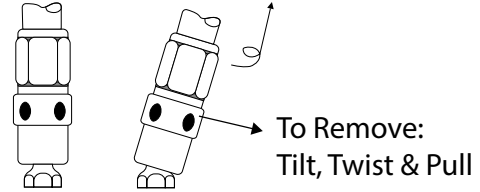

SETUP

WARNING! TO REDUCE THE RISK OF SERIOUS INJURY FROM INJECTION:

It may be necessary to hold the Coupler in place on the zerk fitting while lubricating. **While wearing heavy-duty work gloves, hold the end of the hose by the spring guard only. Keep hands away from exposed rubber part of hose.**

OPERATION

MAINTENANCE

Maintenance and Servicing Instructions



Procedures not specifically explained in this manual must be performed only by a qualified technician.

!WARNING

TO PREVENT SERIOUS INJURY FROM ACCIDENTAL OPERATION:

Make sure that the Trigger is locked and Battery Pack is removed before performing any procedure in this section.

TO PREVENT SERIOUS INJURY FROM TOOL FAILURE:

Do not use damaged equipment. If abnormal noise or vibration occurs, have the problem corrected before further use.

Cleaning, Maintenance, and Lubrication

- BEFORE EACH USE**, inspect the general condition of the tool. Check for:
 - leaking, swollen, or cracked battery pack,
 - loose hardware,
 - misalignment or binding of moving parts,
 - cracked or broken parts, and
 - any other condition that may affect its safe operation.
- AFTER USE**, wipe external surfaces of the tool with clean cloth.
- Li-Ion BATTERY MUST BE RECYCLED OR DISPOSED OF PROPERLY. Do not short, incinerate or open battery.
- Disconnect battery pack and store battery pack, charger, and tool in dry, indoor area out of reach of children and away from metal objects (i.e., paperclips, coins) to prevent shorting.

Troubleshooting

Problem	Possible Causes	Likely Solutions
Decreased output.	Contaminants in pumping mechanism.	Refer to Clearing Contaminants on page 9.
Tool will not start.	<ol style="list-style-type: none"> Battery Pack not properly connected. Battery Pack not properly charged. Battery Pack burnt-out. Internal damage or wear. (Carbon brushes or Trigger, for example.) 	<ol style="list-style-type: none"> Remove Battery Pack, make sure there are no obstructions, reinsert the Battery Pack according to its shape (it should only fit one way), and press firmly until the Battery Pack locks in place. Make sure Charger is connected and operating properly. Give enough time for Battery Pack to recharge properly. Dispose of old Battery Pack properly or recycle. Replace Battery Pack. Have technician service tool.
Tool is not pumping.	<ol style="list-style-type: none"> Grease tube is empty. Air pockets in grease. Contaminants in pumping mechanism. 	<ol style="list-style-type: none"> Fill grease tube. Prime tool according to instructions in General Instructions for Use on page 10. Refer to Clearing Contaminants on page 9.
Grease appears in Pressure Relief Valve.	Clogged/frozen zerk fitting or grease line.	Replace zerk fitting or use grease fitting cleaning tool to clean clog from fittings and joints.
Tool stalls or shuts off.	<ol style="list-style-type: none"> Clogged/frozen zerk fitting or grease line. Contaminants in pumping mechanism. 	<ol style="list-style-type: none"> Replace zerk fitting or use grease fitting cleaning tool to clean clog from fittings and joints. Refer to Clearing Contaminants on page 9



Follow all safety precautions whenever diagnosing or servicing the tool. Disconnect Battery Pack and Charger power supply before service.

PLEASE READ THE FOLLOWING CAREFULLY

THE MANUFACTURER AND/OR DISTRIBUTOR HAS PROVIDED THE PARTS LIST AND ASSEMBLY DIAGRAM IN THIS MANUAL AS A REFERENCE TOOL ONLY. NEITHER THE MANUFACTURER OR DISTRIBUTOR MAKES ANY REPRESENTATION OR WARRANTY OF ANY KIND TO THE BUYER THAT HE OR SHE IS QUALIFIED TO MAKE ANY REPAIRS TO THE PRODUCT, OR THAT HE OR SHE IS QUALIFIED TO REPLACE ANY PARTS OF THE PRODUCT. IN FACT, THE MANUFACTURER AND/OR DISTRIBUTOR EXPRESSLY STATES THAT ALL REPAIRS AND PARTS REPLACEMENTS SHOULD BE UNDERTAKEN BY CERTIFIED AND LICENSED TECHNICIANS, AND NOT BY THE BUYER. THE BUYER ASSUMES ALL RISK AND LIABILITY ARISING OUT OF HIS OR HER REPAIRS TO THE ORIGINAL PRODUCT OR REPLACEMENT PARTS THERETO, OR ARISING OUT OF HIS OR HER INSTALLATION OF REPLACEMENT PARTS THERETO.

Parts List and Diagram

Parts List

Part	Description	Qty
1	Cross Recessed Head Screw	2
2	Baffle Plate	1
3	Sliding Block	1
4	Snap Ring 1	1
5	Gasket	1
6	Bushing 1	1
7	Bushing 2	1
8	Eccentric Wheel	1
9	Output Shaft	1
10	Deep Groove Ball Bearing	2
11	Pump Body	1
12	Snap Ring 2	1
13	Planet Carrier	1
14	Gear 1	1
15	Gear 2	4
16	Gear 3	1
17	Gear 4	4
18	Washer 1	1
19	Gear 5	1
20	Bearing	2
21	Shaft 1	1
22	Gear 6	1
23	Pump Cover	1
24	Screw	2
25	Clip	2
26	Shaft 2	2
27	Plunger	1
28	Oil Seal	1
29	Ball	1
30	Spring	1
31	Washer 2	1
32	Bolt	1
33	Screw 2	1
34	Connector	1
35	O-Ring	1
36	Air Bleed Valve	1
37	Washer 3	1

Part	Description	Qty
38	Safety Valve	1
39	Valve Pocket	1
40	Contact Chip Assembly	1
41	LED Controller	1
42	Trigger	1
43	Trigger Back Panel	1
44	Motor Assembly	1
45	Gear 7	1
46	Cross Recess Pan Head Screw	2
47	Follower Rod	1
48	Shaft 3	2
49	End Cap	1
50	Compression Spring	1
51	Fixed Seat	1
52	Rubber Plug	1
53	Pressing Plate	1
54	Retaining Ring	1
55	Hex Socket Disc Screw	1
56	Holder	1
57	Grease Tube	1
58	Gasket	1
59	Hose Assembly	1
60	Washer 3	1
61	Housing(Left)	1
62	Housing(Right)	1
63	Button	1
64	Lampshade	1
65	Nut	2
66	Fixed Seat	1
67	Shaft	1
68	Trigger Lock	1
69	Coupler Holster	1
70	Grease Hose Holster	1
71	Hexalobular Socket Pan Head Screw	2
72	Hexalobular Socket Pan Screw	12
73	Shoulder Strap (not shown)	1

Assembly Diagram

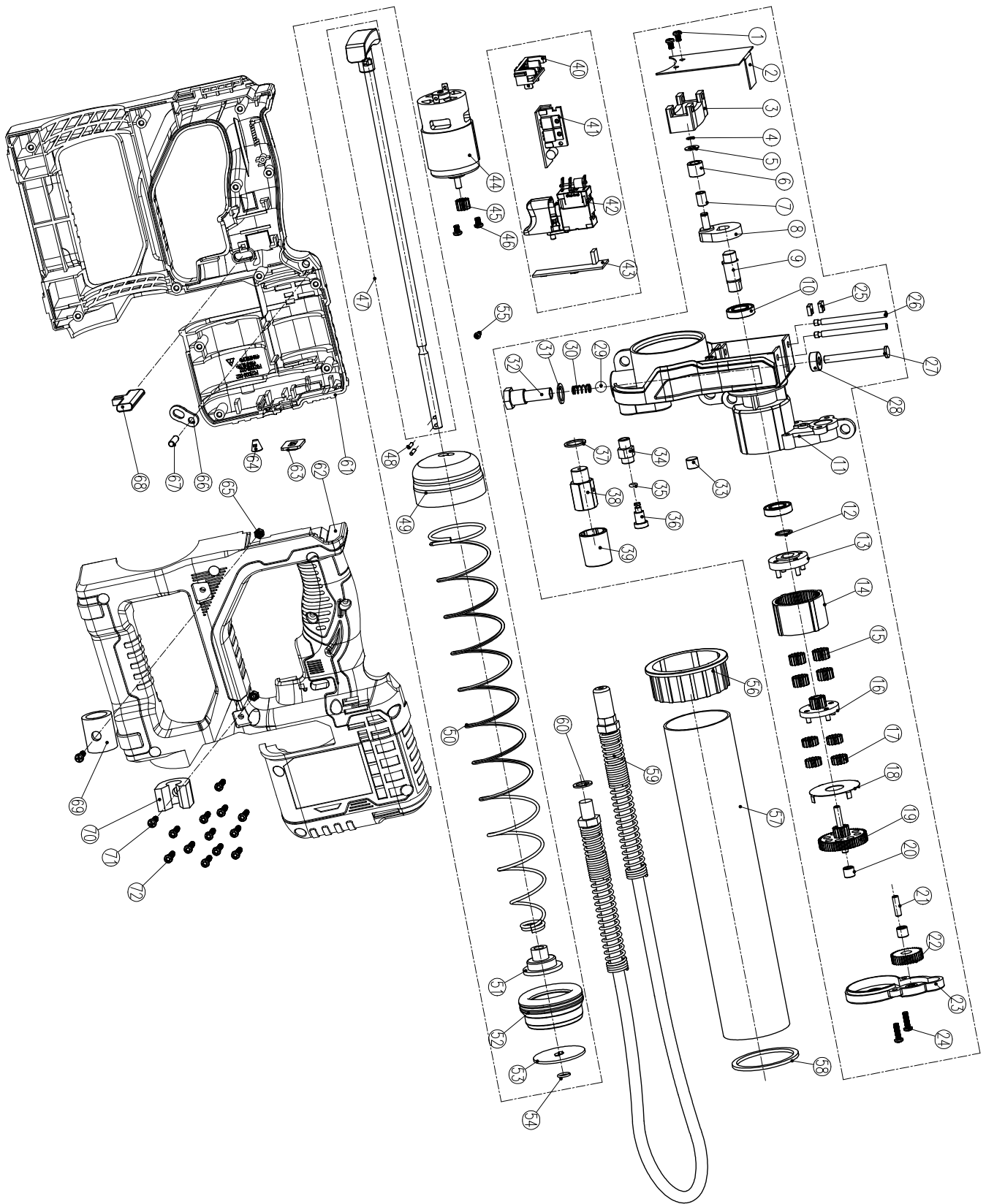

SAFETY

SETUP

OPERATION

MAINTENANCE

SAFETY

SETUP

OPERATION

MAINTENANCE

Record Product's Serial Number Here: _____

Note: If product has no serial number, record month and year of purchase instead.

Note: Some parts are listed and shown for illustration purposes only, and are not available individually as replacement parts. Specify UPC 193175442215 when ordering parts.

Limited 90 Day Warranty

Harbor Freight Tools Co. makes every effort to assure that its products meet high quality and durability standards, and warrants to the original purchaser that this product is free from defects in materials and workmanship for the period of 90 days from the date of purchase. This warranty does not apply to damage due directly or indirectly, to misuse, abuse, negligence or accidents, repairs or alterations outside our facilities, criminal activity, improper installation, normal wear and tear, or to lack of maintenance. We shall in no event be liable for death, injuries to persons or property, or for incidental, contingent, special or consequential damages arising from the use of our product. Some states do not allow the exclusion or limitation of incidental or consequential damages, so the above limitation of exclusion may not apply to you. THIS WARRANTY IS EXPRESSLY IN LIEU OF ALL OTHER WARRANTIES, EXPRESS OR IMPLIED, INCLUDING THE WARRANTIES OF MERCHANTABILITY AND FITNESS.

To take advantage of this warranty, the product or part must be returned to us with transportation charges prepaid. Proof of purchase date and an explanation of the complaint must accompany the merchandise. If our inspection verifies the defect, we will either repair or replace the product at our election or we may elect to refund the purchase price if we cannot readily and quickly provide you with a replacement. We will return repaired products at our expense, but if we determine there is no defect, or that the defect resulted from causes not within the scope of our warranty, then you must bear the cost of returning the product.

This warranty gives you specific legal rights and you may also have other rights which vary from state to state.

SAFETY

SETUP

OPERATION

MAINTENANCE

BauerTM

26677 Agoura Road • Calabasas, CA 91302 • 1-888-866-5797