

# Owner's Manual & Safety Instructions

**Save This Manual** Keep this manual for the safety warnings and precautions, assembly, operating, inspection, maintenance and cleaning procedures. Write the product's serial number in the back of the manual near the assembly diagram (or month and year of purchase if product has no number). Keep this manual and the receipt in a safe and dry place for future reference.

219

# ADMIRAL

®

## 15 AMP 10" TABLE SAW

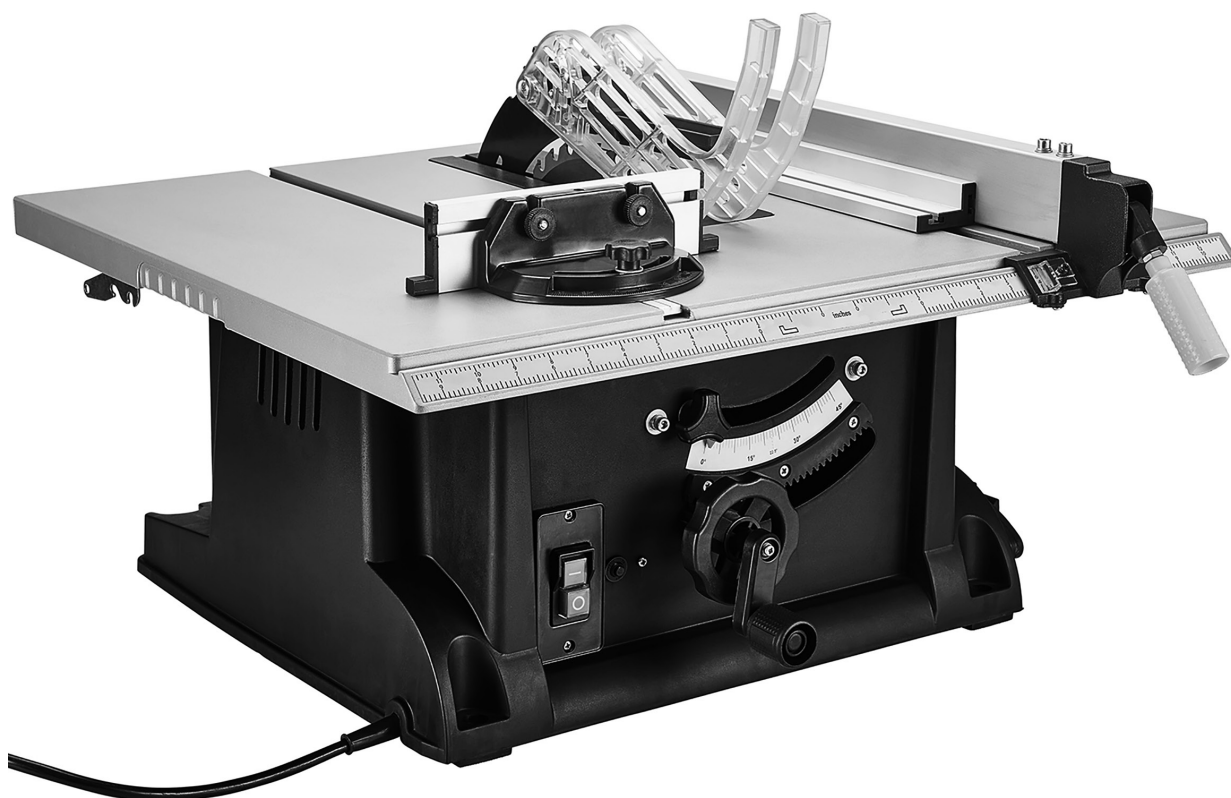

Visit our website at: <http://www.harborfreight.com>  
Email our technical support at: [productsupport@harborfreight.com](mailto:productsupport@harborfreight.com)

58630

When unpacking, make sure that the product is intact and undamaged. If any parts are missing or broken, please call 1-888-866-5797 as soon as possible.

Copyright© 2021 by Harbor Freight Tools®. All rights reserved.  
No portion of this manual or any artwork contained herein may be reproduced in any shape or form without the express written consent of Harbor Freight Tools. Diagrams within this manual may not be drawn proportionally. Due to continuing improvements, actual product may differ slightly from the product described herein.  
Tools required for assembly and service may not be included.

### ⚠ WARNING

Read this material before using this product. Failure to do so can result in serious injury. **SAVE THIS MANUAL.**

# Table of Contents

Safety .....	2	Maintenance .....	16
Specifications .....	8	Parts List and Diagram .....	18
Setup .....	8	Warranty .....	20
Operation.....	13		



SAFETY

SETUP

OPERATION

MAINTENANCE

WARNING SYMBOLS AND DEFINITIONS	
	This is the safety alert symbol. It is used to alert you to potential personal injury hazards. Obey all safety messages that follow this symbol to avoid possible injury or death.
	Indicates a hazardous situation which, if not avoided, will result in death or serious injury.
	Indicates a hazardous situation which, if not avoided, could result in death or serious injury.
	Indicates a hazardous situation which, if not avoided, could result in minor or moderate injury.
	Addresses practices not related to personal injury.

## IMPORTANT SAFETY INFORMATION

### General Power Tool Safety Warnings

#### WARNING

Read all safety warnings, instructions, illustrations and specifications provided with this power tool. Failure to follow all instructions listed below may result in electric shock, fire and/or serious injury.

Save all warnings and instructions for future reference.

The term "power tool" in the warnings refers to your mains-operated (corded) power tool or battery-operated (cordless) power tool.

1. **Work area safety**
  - a. **Keep work area clean and well lit.**  
*Cluttered or dark areas invite accidents.*
  - b. **Do not operate power tools in explosive atmospheres, such as in the presence of flammable liquids, gases or dust.** *Power tools create sparks which may ignite the dust or fumes.*
  - c. **Keep children and bystanders away while operating a power tool.** *Distractions can cause you to lose control.*

## 2. Electrical safety

- a. **Power tool plugs must match the outlet. Never modify the plug in any way. Do not use any adapter plugs with earthed (grounded) power tools. Unmodified plugs and matching outlets will reduce risk of electric shock.**
- b. **Avoid body contact with earthed or grounded surfaces, such as pipes, radiators, ranges and refrigerators. There is an increased risk of electric shock if your body is earthed or grounded.**
- c. **Do not expose power tools to rain or wet conditions. Water entering a power tool will increase the risk of electric shock.**
- d. **Do not abuse the cord. Never use the cord for carrying, pulling or unplugging the power tool. Keep cord away from heat, oil, sharp edges or moving parts. Damaged or entangled cords increase the risk of electric shock.**
- e. **When operating a power tool outdoors, use an extension cord suitable for outdoor use. Use of a cord suitable for outdoor use reduces the risk of electric shock.**
- f. **If operating a power tool in a damp location is unavoidable, use a ground fault circuit interrupter (GFCI) protected supply. Use of a GFCI reduces the risk of electric shock.**

## 3. Personal safety

- a. **Stay alert, watch what you are doing and use common sense when operating a power tool. Do not use a power tool while you are tired or under the influence of drugs, alcohol or medication. A moment of inattention while operating power tools may result in serious personal injury.**
- b. **Use personal protective equipment. Always wear eye protection. Protective equipment such as dust mask, non-skid safety shoes, hard hat, or hearing protection used for appropriate conditions will reduce personal injuries.**
- c. **Prevent unintentional starting. Ensure the switch is in the off-position before connecting to power source and/or battery pack, picking up or carrying the tool. Carrying power tools with your finger on the switch or energizing power tools that have the switch on invites accidents.**
- d. **Remove any adjusting key or wrench before turning the power tool on. A wrench or a key left attached to a rotating part of the power tool may result in personal injury.**
- e. **Do not overreach. Keep proper footing and balance at all times. This enables better control of the power tool in unexpected situations.**

- f. **Dress properly. Do not wear loose clothing or jewelry. Keep your hair, clothing and gloves away from moving parts. Loose clothes, jewelry or long hair can be caught in moving parts.**
- g. **If devices are provided for the connection of dust extraction and collection facilities, ensure these are connected and properly used. Use of dust collection can reduce dust-related hazards.**
- h. **Do not let familiarity gained from frequent use of tools allow you to become complacent and ignore tool safety principles. A careless action can cause severe injury within a fraction of a second.**
- i. Only use safety equipment that has been approved by an appropriate standards agency. Unapproved safety equipment may not provide adequate protection. Eye protection must be ANSI-approved and breathing protection must be NIOSH-approved for the specific hazards in the work area.
- j. Avoid unintentional starting. Prepare to begin work before turning on the tool.
- k. Do not leave the tool unattended when it is plugged into an electrical outlet. Turn off the tool, and unplug it from its electrical outlet before leaving.
- l. This product is not a toy. Keep it out of reach of children.
- m. People with pacemakers should consult their physician(s) before use. Electromagnetic fields in close proximity to heart pacemaker could cause pacemaker interference or pacemaker failure. In addition, people with pacemakers should:
  - Avoid operating alone.
  - Do not use with Trigger locked on.
  - Properly maintain and inspect to avoid electrical shock.
  - Properly ground power cord.
 Ground Fault Circuit Interrupter (GFCI) should also be implemented – it prevents sustained electrical shock.
- n. The warnings, precautions, and instructions discussed in this instruction manual cannot cover all possible conditions and situations that may occur. It must be understood by the operator that common sense and caution are factors which cannot be built into this product, but must be supplied by the operator.

## 4. Power tool use and care

- a. **Do not force the power tool. Use the correct power tool for your application. The correct power tool will do the job better and safer at the rate for which it was designed.**

- b. **Do not use the power tool if the switch does not turn it on and off.** *Any power tool that cannot be controlled with the switch is dangerous and must be repaired.*
  - c. **Disconnect the plug from the power source and/or remove the battery pack, if detachable, from the power tool before making any adjustments, changing accessories, or storing power tools.** *Such preventive safety measures reduce the risk of starting the power tool accidentally.*
  - d. **Store idle power tools out of the reach of children and do not allow persons unfamiliar with the power tool or these instructions to operate the power tool.** *Power tools are dangerous in the hands of untrained users.*
  - e. **Maintain power tools and accessories. Check for misalignment or binding of moving parts, breakage of parts and any other condition that may affect the power tool's operation. If damaged, have the power tool repaired before use.** *Many accidents are caused by poorly maintained power tools.*
  - f. **Keep cutting tools sharp and clean.** *Properly maintained cutting tools with sharp cutting edges are less likely to bind and are easier to control.*
  - g. **Use the power tool, accessories and tool bits etc. in accordance with these instructions, taking into account the working conditions and the work to be performed.** *Use of the power tool for operations different from those intended could result in a hazardous situation.*
  - h. **Keep handles and grasping surfaces dry, clean and free from oil and grease.** *Slippery handles and grasping surfaces do not allow for safe handling and control of the tool in unexpected situations.*
5. **Service**
- a. **Have your power tool serviced by a qualified repair person using only identical replacement parts.** *This will ensure that the safety of the power tool is maintained.*
  - b. Maintain labels and nameplates on the tool. These carry important safety information. If unreadable or missing, contact Harbor Freight Tools for a replacement.
6. **Guarding related warnings**
- a. **Keep guards in place. Guards must be in working order and be properly mounted.** *A guard that is loose, damaged, or is not functioning correctly must be repaired or replaced.*
  - b. **Always use saw blade guard and riving knife for every through-cutting operation.** *For through-cutting operations where the saw blade cuts completely through the thickness of the workpiece, the guard and other safety devices help reduce the risk of injury.*
  - c. **Immediately reattach the guarding system after completing an operation (such as rabbeting, dadoing or resawing cuts) which requires removal of the guard and riving knife.** *The guard and riving knife, help to reduce the risk of injury.*
  - d. **Make sure the saw blade is not contacting the guard, riving knife or the workpiece before the switch is turned on.** *Inadvertent contact of these items with the saw blade could cause a hazardous condition.*
  - e. **Adjust the riving knife as described in this instruction manual.** *Incorrect spacing, positioning and alignment can make the riving knife ineffective in reducing the likelihood of kickback.*
  - f. **For the riving knife to work, it must be engaged in the workpiece.** *The riving knife is ineffective when cutting workpieces that are too short to be engaged with the riving knife. Under these conditions a kickback cannot be prevented by the riving knife.*
  - g. **Use the appropriate saw blade for the riving knife.** *For the riving knife to function properly, the saw blade diameter must match the appropriate riving knife and the body of the saw blade must be thinner than the thickness of the riving knife and the cutting width of the saw blade must be wider than the thickness of the riving knife.*
7. **Cutting procedures warnings**
- a. **▲DANGER: Never place your fingers or hands in the vicinity or in line with the saw blade.** *A moment of inattention or a slip could direct your hand towards the saw blade and result in serious personal injury.*
  - b. **Feed the workpiece into the saw blade only against the direction of rotation.** *Feeding the workpiece in the same direction that the saw blade is rotating above the table may result in the workpiece, and your hand, being pulled into the saw blade.*
  - c. **Never use the miter gauge to feed the workpiece when ripping and do not use the rip fence as a length stop when cross cutting with the miter gauge.** *Guiding the workpiece with the rip fence and the miter gauge at the same time increases the likelihood of saw blade binding and kickback.*

- d. **When ripping, always apply the workpiece feeding force between the fence and the saw blade.** Use a push stick when the distance between the fence and the saw blade is less than 150mm, and use a push block when this distance is less than 50mm. “Work helping” devices will keep your hand at a safe distance from the saw blade.
- e. **Use only the push stick provided by the manufacturer or constructed in accordance with the instructions.** This push stick provides sufficient distance of the hand from the saw blade.
- f. **Never use a damaged or cut push stick.** A damaged push stick may break causing your hand to slip into the saw blade.
- g. **Do not perform any operation “freehand”.** Always use either the rip fence or the miter gauge to position and guide the workpiece. “Freehand” means using your hands to support or guide the workpiece, in lieu of a rip fence or miter gauge. Freehand sawing leads to misalignment, binding and kickback.
- h. **Never reach around or over a rotating saw blade.** Reaching for a workpiece may lead to accidental contact with the moving saw blade.
- i. **Provide auxiliary workpiece support to the rear and/or sides of the saw table for long and/or wide workpieces to keep them level.** A long and/or wide workpiece has a tendency to pivot on the table’s edge, causing loss of control, saw blade binding and kickback.
- j. **Feed workpiece at an even pace.** Do not bend or twist the workpiece. If jamming occurs, turn the tool off immediately, unplug the tool then clear the jam. Jamming the saw blade by the workpiece can cause kickback or stall the motor.
- k. **Do not remove pieces of cut-off material while the saw is running.** The material may become trapped between the fence or inside the saw blade guard and the saw blade pulling your fingers into the saw blade. Turn the saw off and wait until the saw blade stops before removing material.
- l. **Use an auxiliary fence in contact with the table top when ripping workpieces less than 2mm thick.** A thin workpiece may wedge under the rip fence and create a kickback.

## 8. Kickback causes and related warnings

Kickback is a sudden reaction of the workpiece due to a pinched, jammed saw blade or misaligned line of cut in the workpiece with respect to the saw blade or when a part of the workpiece binds between the saw blade and the **rip fence** or other fixed object.

Most frequently during **kickback**, the workpiece is lifted from the table by the rear portion of the saw blade and is propelled towards the operator.

Kickback is the result of saw misuse and/or incorrect operating procedures or conditions and can be avoided by taking proper precautions as given below.

- a. **Never stand directly in line with the saw blade.** Always position your body on the same side of the saw blade as the fence. Kickback may propel the workpiece at high velocity towards anyone standing in front and in line with the saw blade.
- b. **Never reach over or in back of the saw blade to pull or to support the workpiece.** Accidental contact with the saw blade may occur or kickback may drag your fingers into the saw blade.
- c. **Never hold and press the workpiece that is being cut off against the rotating saw blade.** Pressing the workpiece being cut off against the saw blade will create a binding condition and kickback.
- d. **Align the fence to be parallel with the saw blade.** A misaligned fence will pinch the workpiece against the saw blade and create kickback.
- e. **Use a featherboard to guide the workpiece against the table and fence when making non-through cuts such as rabbeting, dadoing or resawing cuts.** A featherboard helps to control the workpiece in the event of a kickback.
- f. **Use extra caution when making a cut into blind areas of assembled workpieces.** The protruding saw blade may cut objects that can cause kickback.
- g. **Support large panels to minimise the risk of saw blade pinching and kickback.** Large panels tend to sag under their own weight. Support(s) must be placed under all portions of the panel overhanging the table top.
- h. **Use extra caution when cutting a workpiece that is twisted, knotted, warped or does not have a straight edge to guide it with a miter gauge or along the fence.** A warped, knotted, or twisted workpiece is unstable and causes misalignment of the kerf with the saw blade, binding and kickback.
- i. **Never cut more than one workpiece, stacked vertically or horizontally.** The saw blade could pick up one or more pieces and cause kickback.

- j. When restarting the saw with the saw blade in the workpiece, center the saw blade in the kerf so that the saw teeth are not engaged in the material. If the saw blade binds, it may lift up the workpiece and cause kickback when the saw is restarted.
  - k. Keep saw blades clean, sharp, and with sufficient set. Never use warped saw blades or saw blades with cracked or broken teeth. Sharp and properly set saw blades minimize binding, stalling and kickback.
9. Table saw operating procedure warnings
- a. Turn off the table saw and disconnect the power cord when removing the table insert, changing the saw blade or making adjustments to the riving knife or saw blade guard, and when the machine is left unattended. Precautionary measures will avoid accidents.
  - b. Never leave the table saw running unattended. Turn it off and don't leave the tool until it comes to a complete stop. An unattended running saw is an uncontrolled hazard.
  - c. Locate the table saw in a well-lit and level area where you can maintain good footing and balance. It should be installed in an area that provides enough room to easily handle the size of your workpiece. Cramped, dark areas, and uneven slippery floors invite accidents.
  - d. Frequently clean and remove sawdust from under the saw table and/or the dust collection device. Accumulated sawdust is combustible and may self-ignite.
  - e. The table saw must be secured. A table saw that is not properly secured may move or tip over.
  - f. Remove tools, wood scraps, etc. from the table before the table saw is turned on. Distraction or a potential jam can be dangerous.
  - g. Always use saw blades with correct size and shape (diamond versus round) of arbor holes. Saw blades that do not match the mounting hardware of the saw will run off-center, causing loss of control.
  - h. Never use damaged or incorrect saw blade mounting means such as flanges, saw blade washers, bolts or nuts. These mounting means were specially designed for your saw, for safe operation and optimum performance.
  - i. Never stand on the table saw, do not use it as a stepping stool. Serious injury could occur if the tool is tipped or if the cutting tool is accidentally contacted.
  - j. Make sure that the saw blade is installed to rotate in the proper direction. Do not use grinding wheels, wire brushes, or abrasive wheels on a table saw. Improper saw blade installation or use of accessories not recommended may cause serious injury.

## Grounding

### ⚠ WARNING



TO PREVENT ELECTRIC SHOCK AND DEATH FROM INCORRECT GROUNDING WIRE CONNECTION:

Check with a qualified electrician if you are in doubt as to whether the outlet is properly grounded. Do not modify the power cord plug provided with the tool. Never remove the grounding prong from the plug. Do not use the tool if the power cord or plug is damaged. If damaged, have it repaired by a service facility before use. If the plug will not fit the outlet, have a proper outlet installed by a qualified electrician.

## Double Insulated Tools: Tools with Two Prong Plugs

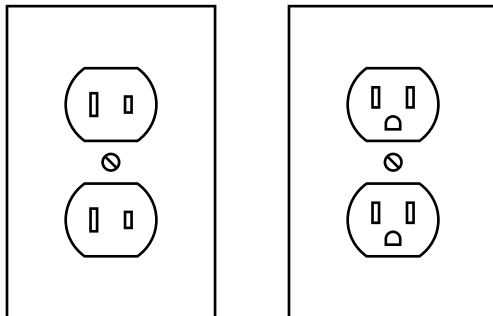

Outlets for 2-Prong Plug

1. Tools marked "Double Insulated" do not require grounding. They have a special double insulation system which satisfies OSHA requirements and complies with the applicable standards of Underwriters Laboratories, Inc., the Canadian Standard Association, and the National Electrical Code.
2. Double insulated tools may be used in either of the 120 volt outlets shown in the preceding illustration. (See Outlets for 2-Prong Plug.)

# Extension Cords

- Grounded** tools require a three wire extension cord. **Double Insulated** tools can use either a two or three wire extension cord.
- As the distance from the supply outlet increases, you must use a heavier gauge extension cord. Using extension cords with inadequately sized wire causes a serious drop in voltage, resulting in loss of power and possible tool damage. **(See Table A.)**
- The smaller the gauge number of the wire, the greater the capacity of the cord. For example, a 14 gauge cord can carry a higher current than a 16 gauge cord. **(See Table A.)**
- When using more than one extension cord to make up the total length, make sure each cord contains at least the minimum wire size required. **(See Table A.)**
- If you are using one extension cord for more than one tool, add the nameplate amperes and use the sum to determine the required minimum cord size. **(See Table A.)**
- If you are using an extension cord outdoors, make sure it is marked with the suffix "W-A" ("W" in Canada) to indicate it is acceptable for outdoor use.

- Make sure the extension cord is properly wired and in good electrical condition. Always replace a damaged extension cord or have it repaired by a qualified electrician before using it.
- Protect the extension cords from sharp objects, excessive heat, and damp or wet areas.

**TABLE A: RECOMMENDED MINIMUM WIRE GAUGE FOR EXTENSION CORDS\* (120/240 VOLT)**

NAMEPLATE AMPERES (at full load)	EXTENSION CORD LENGTH				
	25'	50'	75'	100'	150'
0 – 2.0	18	18	18	18	16
2.1 – 3.4	18	18	18	16	14
3.5 – 5.0	18	18	16	14	12
5.1 – 7.0	18	16	14	12	12
7.1 – 12.0	18	14	12	10	-
12.1 – 16.0	14	12	10	-	-
16.1 – 20.0	12	10	-	-	-

\* Based on limiting the line voltage drop to five volts at 150% of the rated amperes.

## Symbology

	Double Insulated
<b>V</b>	Volts
~	Alternating Current
<b>A</b>	Amperes
n <sub>0</sub> xxxx/min.	No Load Revolutions per Minute (RPM)

	WARNING marking concerning Risk of Eye Injury. Wear ANSI-approved safety goggles with side shields.
	Read the manual before set-up and/or use.
	WARNING marking concerning Risk of Fire. Do not cover ventilation ducts. Keep flammable objects away.
	WARNING marking concerning Risk of Electric Shock. Properly connect power cord to appropriate outlet.

## Specifications

Electrical Rating	120VAC / 60Hz / 15A
Rated No Load Speed	$n_0$ : 4600/min
Cutting Capacity at 0°	3-1/8"
Cutting Capacity at 45°	2-1/4"
Maximum Bevel	45°
Maximum Miter	45°
Saw Blade	10" (254mm) Diameter, 7/64" Wide 5/8" Diamond Arbor

## Setup - Before Use:



Read the **ENTIRE IMPORTANT SAFETY INFORMATION** section at the beginning of this manual including all text under subheadings therein before set up or use of this product.

### **WARNING**

**TO PREVENT SERIOUS INJURY FROM ACCIDENTAL OPERATION:**

Turn the Power Switch of the tool off and unplug the tool from its electrical outlet before performing any procedure in this section.

**Note:** For additional information regarding the parts listed in the following pages, refer to *Parts List and Diagram* on page 18.

## Mounting

**Note:** Table Saw **MUST** be mounted onto a surface for proper use.

### **If mounting onto a metal table stand:**

1. Select a table stand which will support the weight of the Table Saw. Follow the table saw stand instructions for assembly. Tighten all connections, making sure the assembled table is secure and balanced.
2. Mount the Table Saw to the top of the assembled stand using four 3/8" bolts, eight 3/8" washers and four 3/8" nuts (not included).

### **If mounting onto a bench or other wooden surface:**

1. Select four 3/8" bolts, eight 3/8" washers, and four 3/8" nuts\* (not included).  
\*Screws and washers may be used instead, if desired.
2. Place the Table Saw where it will be mounted. Make a mark in the center of each of the 4 mounting holes. Set the Saw aside.

### **WARNING! TO PREVENT SERIOUS INJURY:**

Before drilling the holes, make sure that there are no electric wires, cables, utility lines or other obstructions in the area to be drilled.

3. Drill the holes straight down, large enough to allow your mounting hardware to fit.
4. Put the Table Saw in place and mount using the hardware mentioned above. Tighten all hardware securely before use.

## Power Supply Requirements

1. Connect to grounded 120VAC, 20A receptacle.



# Functions

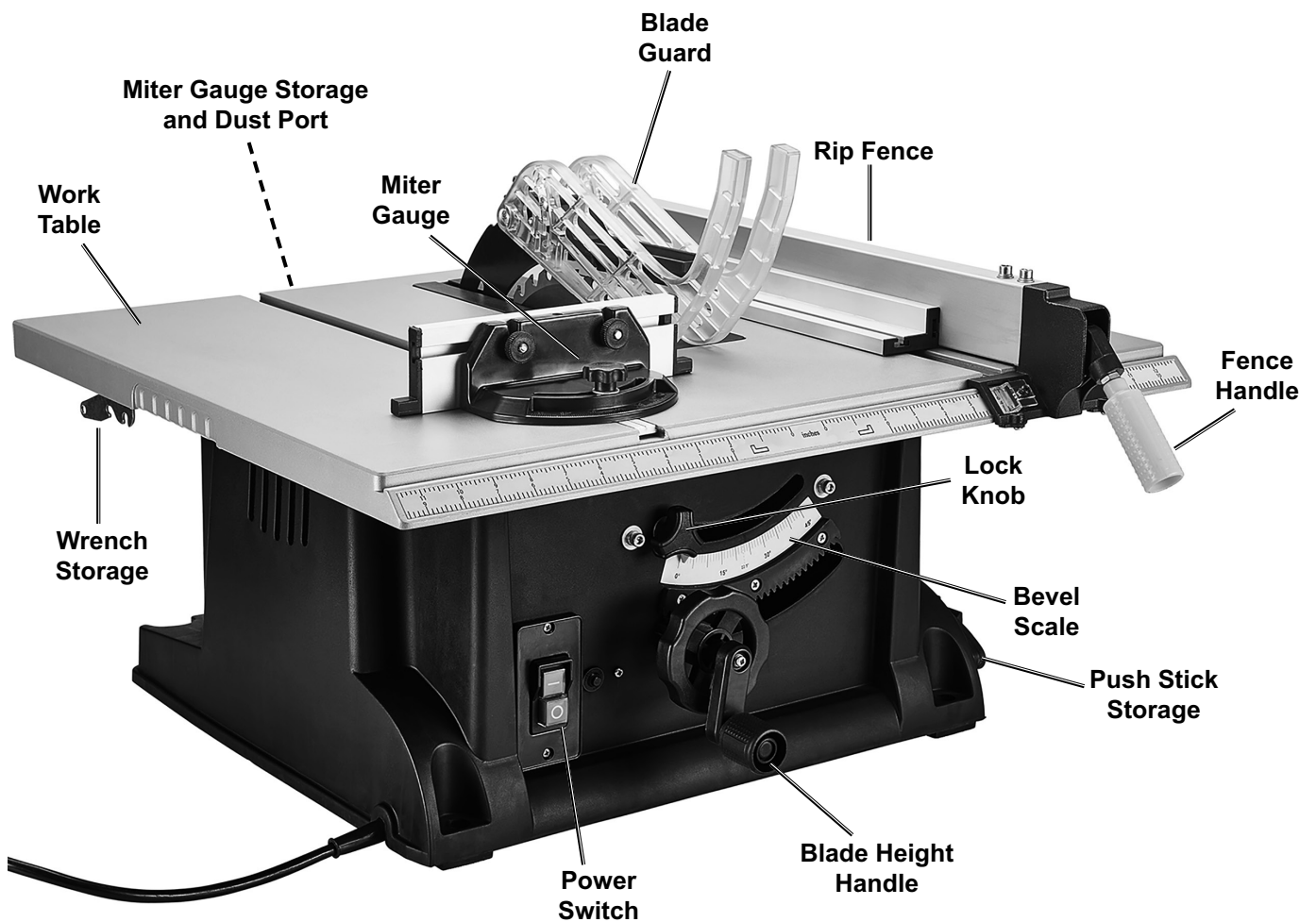

SAFETY

SETUP

OPERATION

MAINTENANCE

## Saw Blade Selection

1. Any saw blade that will be used must be marked as suitable for the material to be cut.
2. Match the saw blade diameter, kerf width and body dimensions to the riving knife.
3. Use only saw blades that are marked with a speed equal or higher than the speed marked on the tool.

## Bevel Angle Setting

1. Loosen Lock Knob, then move Blade Height Handle until red indicator points to desired angle.
2. Tighten Lock Knob.

## Blade Depth Adjustment

**Note:** Blade depth should be set so that outer points of blade are higher than workpiece by approximately 1/8" to 1/4" and bottom of gullets are below top surface of workpiece.

1. Loosen Lock Knob, then move Blade Height Handle until red indicator points to 0°.
2. Tighten Lock Knob.
3. Turn Height Handle until desired depth is achieved.

## Riving Knife Adjustment

**Note:** Riving Knife is permanently installed. It comes in its lowest position for shipping. Reposition the Riving Knife according to type of cut before use.

1. Remove Table Insert by using the round hole provided in the Insert to lift.

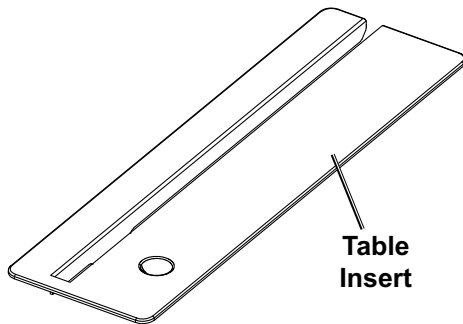

2. Raise Riving Knife Lock.

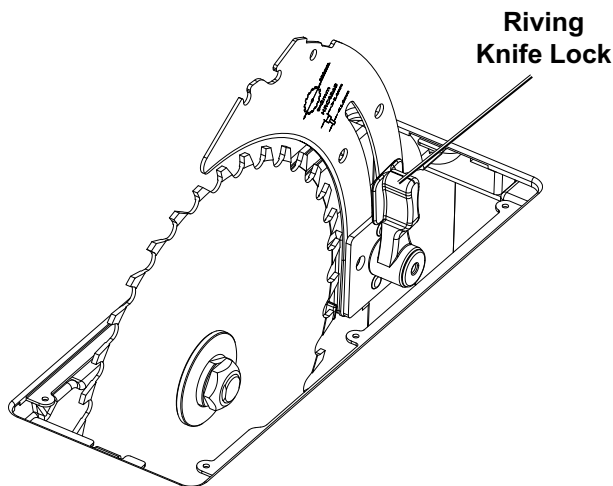

3. Adjust Riving Knife to proper position for type of cut:
  - a. Through Cut

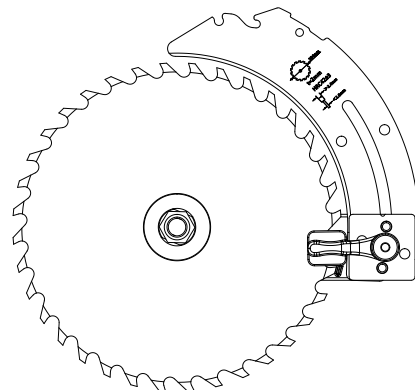

- b. Non-Through Cut

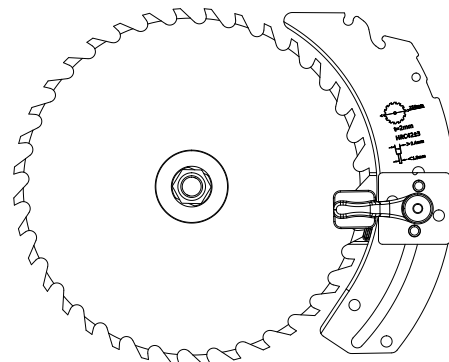

4. Lower Riving Knife Lock and replace Table Insert.

## Install Blade Guard

**WARNING!** Always use saw blade guard and riving knife for every through-cutting operation. For through-cutting operations where the saw blade cuts completely through the thickness of the workpiece, the guard and other safety devices help reduce the risk of serious injury.

1. Press in Guard Lock Button, then place Blade Guard on top of Riving Knife so the Roller slides into open slot at top of Riving Knife. Push Guard to the back of the slot, then release Guard Lock Button.
2. Make sure Blade Guard is fully engaged, aligned properly and does not contact the Blade.
3. Adjust Blade Guard to prevent contact with Saw Blade.

**WARNING! TO PREVENT SERIOUS INJURY:**

The Blade Guard must be removed for making non-through cuts and must be reinstalled after making non-through cuts.

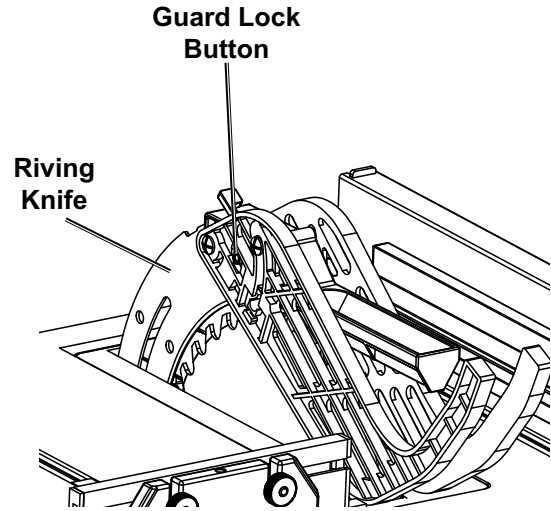

## Install Rip Fence

**WARNING! TO PREVENT SERIOUS INJURY:**

To prevent kickback, make sure Rip Fence is parallel to the blade and locked in place. Do not use Rip Fence when cutting across wood grain (crosscutting).

**Note:** The Rip Fence can be installed on either side of Blade.

1. Raise Rip Fence Handle.
2. Place Rip Fence on Work Table, then side to desired location using Scale if necessary.
3. Lower Rip Fence Handle.

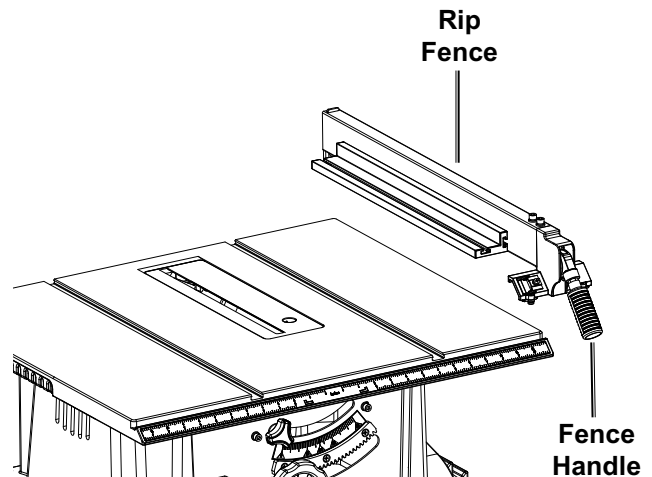

## Dust Extraction Setup

Attach dust collection system to Dust Port.



# Essential Straight Push-stick Features and Functions

SAFETY

SETUP

OPERATION

MAINTENANCE

**Note:** Straight style (traditional) stick shown. A different stick design may be used if it properly protects against all hazards.

**Diagram not to scale.**

- Push sticks must be made from sturdy, defect-free, plywood or normal wood to prevent unexpected breakage. Material must be at least 1/4" thick, but no thicker than the finished wood.
- Inspect push stick before use and do not use a damaged or deteriorated push stick.
- Push stick dimensions will vary depending on the application and user.

## Handle Notch

- Must be far enough down the stick to allow a comfortable and firm grip.
- Must be deep enough to prevent hand from slipping down the stick.
- Do not cut more than halfway into the stick to prevent weakening.
- Corners may be rounded to increase comfort.

## Stick Length

- Must be long enough to keep hand clear of blade.
- At least 6" from end of handle to closest part of notch.

## Notch

- Must be right (90°) angle, cut at 30°-40° from the angle of the stick to keep hands out of the line of the blade.
- The lower lip of the notch must be no longer than the workpiece is thick.

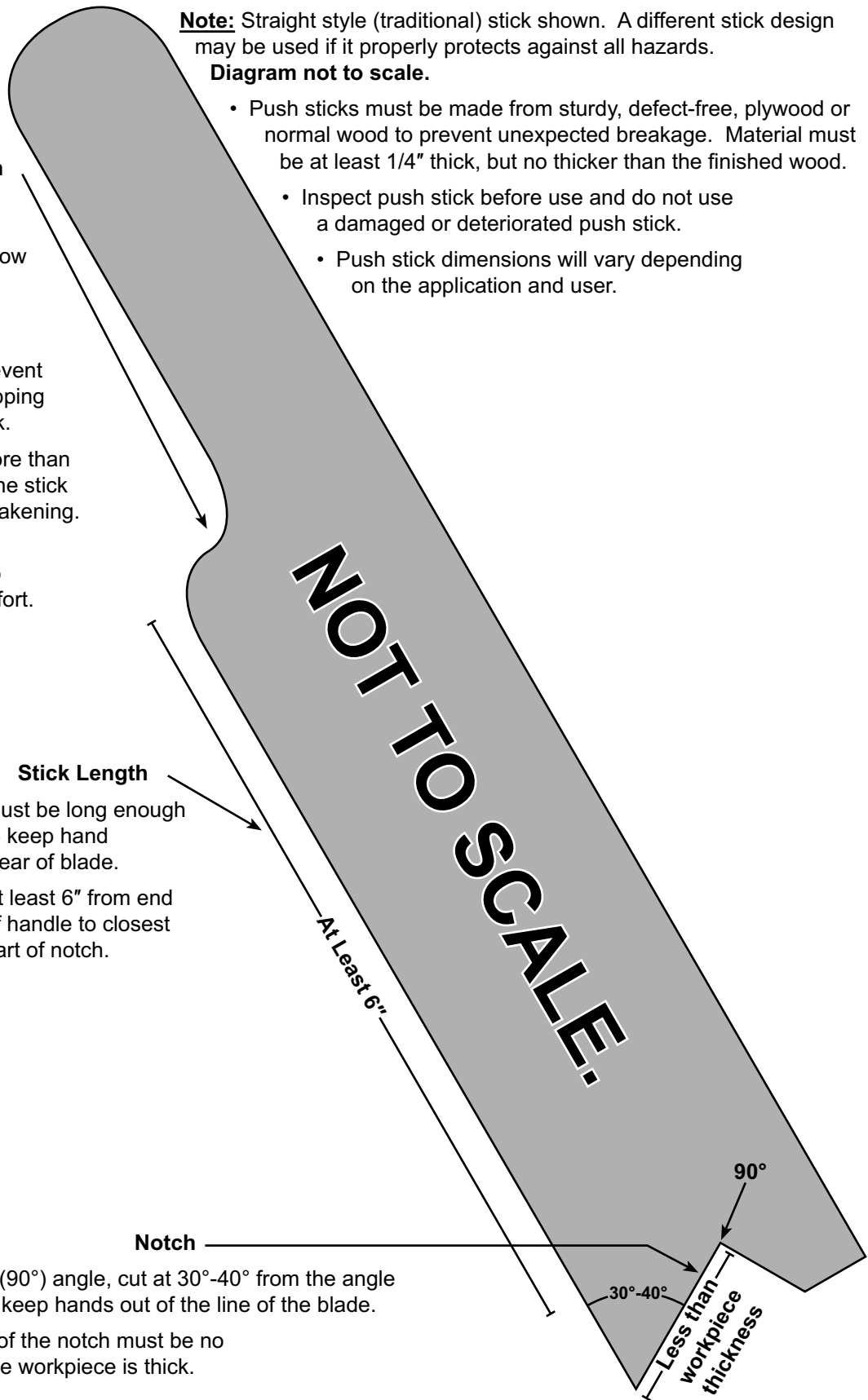

## Operating Instructions



Read the **ENTIRE IMPORTANT SAFETY INFORMATION** section at the beginning of this manual including all text under subheadings therein before set up or use of this product.

### **WARNING**

#### **TO PREVENT SERIOUS INJURY:**

Wear ANSI-approved safety goggles and hearing protection during operation.

Wear heavy-duty work gloves when handling saw blades.

#### **WARNING! TO PREVENT SERIOUS INJURY FROM ACCIDENTAL OPERATION:**

Make sure that the Trigger is in the off-position and unplug the tool from its electrical outlet before performing any procedure in this section.

## Blade Changing

**WARNING! TO PREVENT SERIOUS INJURY:** Make sure that the saw blade is installed to rotate in the proper direction. Do not use grinding wheels, wire brushes, or abrasive wheels on a table saw. Improper saw blade installation or use of accessories not recommended may cause serious injury.

Only use a 10" saw blade with a 5/8" diamond arbor, rated to at least 4,800 RPM and intended for woodcutting.

1. Turn Power Switch off and unplug the tool from its power source.
2. Loosen Lock Knob, then move Blade Height Handle to 0°. Tighten Lock Lever.
3. Turn Blade Height Handle to lower the Blade completely.

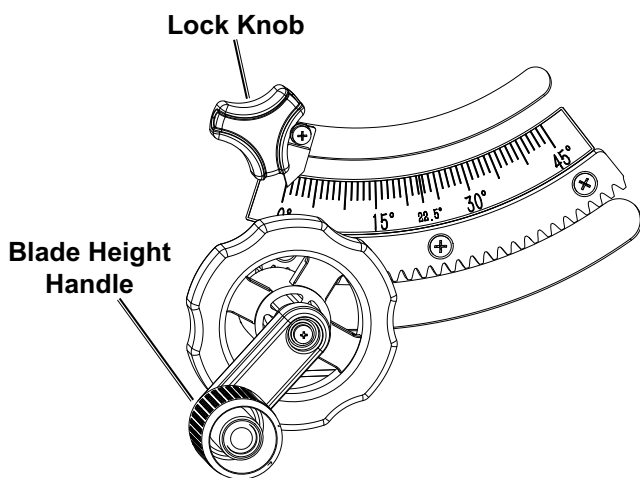

5. Remove Table Insert, pull up by using hole.

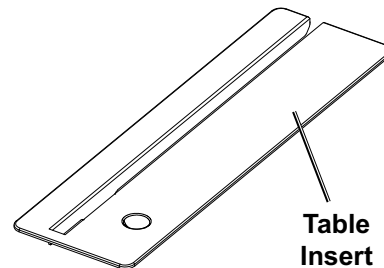

4. Press Guard Lock Button, then remove Blade Guard.

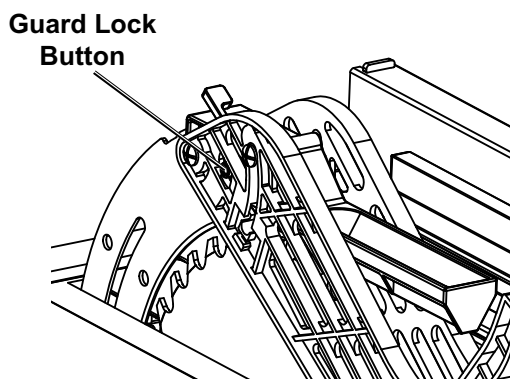

6. Raise Blade completely, then move Blade Height Handle to 15°.
7. Use two included wrenches, one to hold the Inner Flange and the other to loosen the Blade Nut.
8. Remove Blade Nut, Outer Flange and Blade.

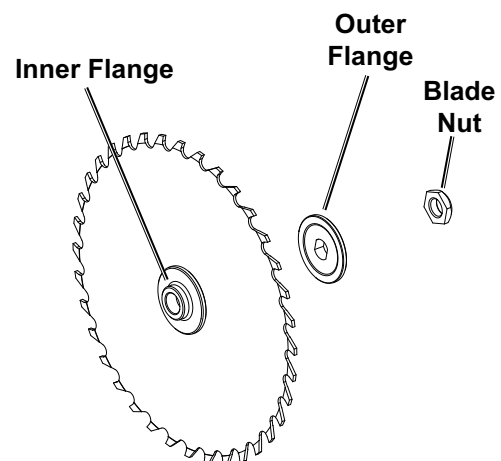

9. Install new Blade with teeth pointing forward. Replace Outer Flange and Blade Nut, then, tighten Blade Nut. **DO NOT** overtighten.
10. Move Blade Height Handle to 0°. Lower Saw blade completely, then replace Table Insert and Blade Guard.

# Workpiece and Work Area Set Up

1. Designate a work area that is clean and well lit. The work area must not allow access by children or pets to prevent distraction and injury.
2. Route the power cord along a safe route to reach the work area without creating a tripping hazard or exposing the power cord to possible damage. The power cord must reach the work area with enough extra length to allow free movement while working.
3. There must not be objects, such as utility lines, nearby that will present a hazard while working.
4. Cut only the following materials:  
Dimensional lumber, plywood, particle board.
5. Use an auxiliary fence to be in contact with the table top when cutting thin workpieces;
6. Allow room on both sides of saw for extended workpieces.
7. Use additional supports if needed to ensure the stability of the workpiece. Mount the Saw so that the surface is level to the ground, and additional supports to provide a surface on the same level as the saw table. If the work surface and any workpiece supports are not level, and on the same level, unwanted bevel angles will appear in the cuts resulting in poor joinery.

**Note:** Use caution to avoid overheating the cutting tips.

## General Instructions for Use



### **⚠ DANGER**

**SAWS CAN QUICKLY AMPUTATE FINGERS IF MISUSED.**

Keep hands well clear of cutting area.

**DO NOT OPERATE WITH ANY GUARD DISABLED, DAMAGED, OR REMOVED.**

Moving guards must move freely and close instantly.

**INSTALL GUARD BEFORE USE.**

### Proper Placement Of Hands During the Cutting Process

1. Review Safety warnings at the beginning of the manual before performing any cutting procedure. Keep all guards in place and in working order.
2. Do not pass hands directly over the Saw Blade when cutting the workpiece. Push the workpiece into the Saw Blade using a Push-stick, push-block or by holding the workpiece against the Miter Gauge.

**WARNING! SAFE CUTTING PROCEDURES VARY DEPENDING ON THE TYPE OF CUT. TO PREVENT SERIOUS INJURY FROM KICKBACK:**

**Use Fence for every Rip Cut**  
(cut along with the grain).

**BUT**

**Do not use Fence for any crosscut**  
(cut against the grain).

#### Rip Cuts

1. Rip cuts are straight cuts made parallel to (along with) the grain of the wood by sliding the workpiece along the Fence.
2. For pieces wider than 6", hold the workpiece, staying clear of the Saw Blade. For pieces between 2" and 6", use the included Push-stick or make a push-stick as described in the Safety section of this manual. Use a Push-block (not included) when ripping widths under 2".
3. When ripping, always use the Rip Fence. This improves the accuracy of the cut, and reduces the chance for Saw Blade binding.

#### Crosscuts/Miter Cuts

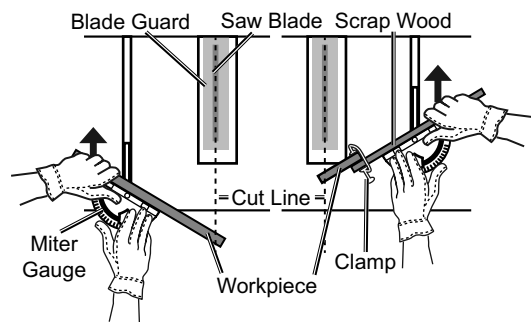

1. Adjust the Miter Gauge to the needed angle and place it in the right or left slot on the Table.
2. Hold the workpiece against the Miter Gauge, and slide them together to make the cut. Clamp smaller pieces to a piece of scrap wood that can reach beyond the Miter Gauge and hold the scrap against the Gauge while making the cut. Keep the clamp clear of the Saw Blade.

## Making a Cut

1. After adjusting the width and/or angle of the cut, plug the Table Saw into a grounded 120V outlet.
2. Turn the Power Switch on.

**WARNING!** Avoid bevel ripping on bevelling side of the saw blade.

**WARNING! TO PREVENT SERIOUS INJURY:**  
The tool will restart automatically if stalled.

3. At the start of the cut, the left hand holds the workpiece firmly on the Work Table (and against the Fence, if used), and the right hand, with the aid of a Push-stick, pushes the workpiece toward the turning Saw Blade. Keep both hands out of the path of the Saw Blade.

**WARNING! TO PREVENT SERIOUS INJURY:**

- Throughout the cut, keep all body parts a safe distance from the spinning Blade.
4. After the cut is under way, use the Push Stick to continue guiding the workpiece forward. Just before the cut is completed, move the left hand safely farther away from the workpiece and the Saw Blade. Continue pushing the workpiece into the Saw Blade with the Push Stick until the cut is complete.
  5. Once the cut is complete, continue to maintain control of the workpiece. Turn the Switch off. Then, wait until the Saw Blade completely stops rotating before removing the workpiece.
  6. To prevent accidents, turn off the Table Saw, and unplug it after use. Clean, then cover and store the Saw indoors out of children's reach.

## Making a Non-Through Cut

1. Unplug saw and remove Blade Guard.
2. Place Riving Knife in Non-Through Cut position. (See b. Non-Through Cut on page 10).
3. Unlock Bevel Lock and set the bevel angle to 0°, then secure Bevel Lock.
4. Set the blade to the correct depth for the workpiece.
5. Use either the Rip Fence or Miter Gauge, depending on the shape and size of the wood.
6. Plug the saw back in and turn Power on.
7. Allow the blade to reach full speed before moving the workpiece into the blade.

**WARNING:** Always use Push Blocks, Push Sticks, and/or Featherboards appropriately when making non-through cuts to reduce the risk of serious injury.

8. After the cut has been made, turn saw off. Allow the blade to come to a complete stop before removing the workpiece.
9. **WARNING! TO PREVENT SERIOUS INJURY:** Reposition Riving Knife and reinstall Blade Guard before doing any other type of cut and after use, even if you intend to do more non-through cuts at another time. The Blade Guard is a critical safety component and must be used whenever practical.

## Making and Using a Jig

**Note:** A jig is used for all tapered cuts.

1. Use recessed screws to secure a handle to a long, straight piece of wood.
2. Cut an L-shaped stop in the left side of the jig.

3. Position the workpiece flat on the table with the edge flush against the jig and against the L-shaped stop.
4. Hold jig handle and use a push block (sold separately) while making a tapered cut.

## Making and Using an Auxiliary Fence

**Note:** An auxiliary fence is used for rip cutting thin workpieces.

1. Use a piece of wood that is 3/4" thick, 3-1/2" wide, and 18-1/2" long.
2. Place the wood piece against left side of rip fence and rest firmly on the saw table.
3. Secure wood piece to the fence using 1-1/2" wood screws.

## Maintenance and Servicing Instructions



Procedures not specifically explained in this manual must be performed only by a qualified technician.

### **⚠️ WARNING**

**TO PREVENT SERIOUS INJURY FROM ACCIDENTAL OPERATION:**

Make sure that the Trigger is in the off-position and unplug the tool from its electrical outlet before performing any procedure in this section.

**TO PREVENT SERIOUS INJURY FROM TOOL FAILURE:**

Do not use damaged equipment. If abnormal noise or vibration occurs, have the problem corrected before further use.

## Cleaning, Maintenance, and Lubrication

- BEFORE EACH USE**, inspect the general condition of the tool. Check for:
  - loose hardware,
  - misalignment or binding of moving parts,
  - damaged cord/electrical wiring,
  - cracked or broken parts, and
  - any other condition that may affect its safe operation.
- AFTER USE**, wipe external surfaces of the tool with clean cloth.
- Remove cut-off pieces and scraps from the Table before starting the Table Saw.** Switch off the tool. While the Saw Blade is completely stopped; unplug the machine, remove the Blade, and remove all debris. With a brush, soft cloth, or vacuum, remove all sawdust from the Table Saw.  
**Allowing sawdust, scraps, or other debris to accumulate can cause a fire, resulting in severe personal injury or property damage.**
- Do not use solvents to wipe off the Table Saw, as damage may result. If necessary, wipe with a damp cloth. You may use a mild detergent.  
**Do not introduce water into the electric motor through the motor vents.**
- Once clean, lubricate all moving parts with a light oil.
- When storing, keep the Table Saw covered with a cloth cover.
- ⚠️ WARNING! TO PREVENT SERIOUS INJURY: If the plug or the supply cord of this power tool is damaged, it must be replaced only by a qualified service technician.**



# Troubleshooting

Problem	Possible Causes	Likely Solutions
Tool will not start.	<ol style="list-style-type: none"> <li>1. Cord not connected.</li> <li>2. No power at outlet.</li> <li>3. Tool's thermal reset breaker tripped (if equipped).</li> <li>4. Internal damage or wear. (Carbon brushes or Trigger, for example.)</li> </ol>	<ol style="list-style-type: none"> <li>1. Check that cord is plugged in.</li> <li>2. Check power at outlet. If outlet is unpowered, turn off tool and check circuit breaker. If breaker is tripped, make sure circuit is right capacity for tool and circuit has no other loads.</li> <li>3. Turn off tool and allow to cool. Press reset button on tool.</li> <li>4. Have technician service tool.</li> </ol>
Tool operates slowly.	<ol style="list-style-type: none"> <li>1. Forcing tool to work too fast.</li> <li>2. Extension cord too long or cord diameter too small.</li> </ol>	<ol style="list-style-type: none"> <li>1. Allow tool to work at its own rate.</li> <li>2. Eliminate use of extension cord. If an extension cord is needed, use one with the proper diameter for its length and load. See <i>Extension Cords</i> in <i>Grounding</i> section on page 6.</li> </ol>
Performance decreases over time.	Carbon brushes worn or damaged.	Have qualified technician replace brushes.
Excessive noise or rattling.	Internal damage or wear. (Carbon brushes or bearings, for example.)	Have technician service tool.
Overheating.	<ol style="list-style-type: none"> <li>1. Forcing tool to work too fast.</li> <li>2. Blocked motor housing vents.</li> <li>3. Motor being strained by long or small diameter extension cord.</li> </ol>	<ol style="list-style-type: none"> <li>1. Allow tool to work at its own rate.</li> <li>2. Wear ANSI-approved safety goggles and NIOSH-approved dust mask/respirator while blowing dust out of motor using compressed air.</li> <li>3. Eliminate use of extension cord. If an extension cord is needed, use one with the proper diameter for its length and load. See <i>Extension Cords</i> in <i>Grounding</i> section on page 6.</li> </ol>
 <p><b>Follow all safety precautions whenever diagnosing or servicing the tool. Disconnect power supply before service.</b></p>		

## PLEASE READ THE FOLLOWING CAREFULLY

THE MANUFACTURER AND/OR DISTRIBUTOR HAS PROVIDED THE PARTS LIST AND ASSEMBLY DIAGRAM IN THIS MANUAL AS A REFERENCE TOOL ONLY. NEITHER THE MANUFACTURER OR DISTRIBUTOR MAKES ANY REPRESENTATION OR WARRANTY OF ANY KIND TO THE BUYER THAT HE OR SHE IS QUALIFIED TO MAKE ANY REPAIRS TO THE PRODUCT, OR THAT HE OR SHE IS QUALIFIED TO REPLACE ANY PARTS OF THE PRODUCT. IN FACT, THE MANUFACTURER AND/OR DISTRIBUTOR EXPRESSLY STATES THAT ALL REPAIRS AND PARTS REPLACEMENTS SHOULD BE UNDERTAKEN BY CERTIFIED AND LICENSED TECHNICIANS, AND NOT BY THE BUYER. THE BUYER ASSUMES ALL RISK AND LIABILITY ARISING OUT OF HIS OR HER REPAIRS TO THE ORIGINAL PRODUCT OR REPLACEMENT PARTS THERETO, OR ARISING OUT OF HIS OR HER INSTALLATION OF REPLACEMENT PARTS THERETO.

**Record Product's Serial Number Here:** \_\_\_\_\_

**Note:** If product has no serial number, record month and year of purchase instead.

**Note:** Some parts are listed and shown for illustration purposes only, and are not available individually as replacement parts. Specify UPC 193175444776 when ordering parts.

Parts List

SAFETY

SETUP

OPERATION

MAINTENANCE

Part	Description	Qty	Part	Description	Qty	Part	Description	Qty
1	Plate	2	49	Pin 5x32	1	97	Carbon Brush	2
2	Nut M6	2	50	Blade Guard Right	1	99	Washer 5x10x1	2
3	Spring	1	51	Washer 6x12x0.8	3	100	Screw M5x12	2
4	Plate	1	52	Pad	1	101	Screw Rod	1
5	Gasket	2	53	Riving Knife Base	1	102	Gear	2
6	Long Screw	1	54	Bolt M6x20	2	103	Screw M4 X 20 (Set)	2
7	Fence	1	55	Cylindrical Pin 8 X 16	2	104	Sleeve	1
8	Bolt M6x10	6	56	Plate	1	105	Washer 8x17x1.5	1
9	Knob	4	57	Spring	1	106	Clip	1
10	Bolt M6x10	6	58	Pin	1	107	Clamping	1
11	Fence Pointer	1	59	Cylindrical Pin 2.5x14	1	108	Feet	4
12	Fence Handle Base	1	60	Locking Handle	1	109	Power Cord	1
13	Fixed Pulley	1	61	Spring	1	110	Strain Relief Cylinder	1
14	Washer	2	62	Handle Cap	1	111	Screw St4.2x 20	3
15	Fence Handle	1	63	Washer 4x12x1	4	112	Clamp	1
16	Nut M8	1	64	Lower Guard	1	113	Switch Box	1
17	Holder	1	65	Blade Bolt	1	114	Reset Button	1
18	Cap	1	66	Outer Flange	1	115	Switch	1
19	Bolt M6x40	2	67	Saw Blade	1	116	Switch Cover	1
20	Barrier	1	68	Inner Flange	1	117	Screw M5 X 16	3
21	Cap	1	69	Cover	1	118	Rack	1
22	Spring	1	70	Screw M4 X 12 (Set)	3	120	Angle Pointer	1
23	Table	1	71	Gear Box Cover	1	121	Knob	1
24	Screw M4 X 6	1	72	Bearing 6003(Z2)	1	122	Screw 6	1
25	Clip	1	73	Woodruff Key 4x5x13	1	123	Limiter	2
26	Table Insert	1	74	Output Axis	1	124	Housing	1
27	Washer 6 (6x18x1.5)	5	75	Crown Gear	1	125	Knob	1
28	Screw M6 X 25	4	76	Circlip	1	126	Screw M4 X 16	1
29	Seat	2	77	Bearing 698(Z2)	1	127	Blade Height Handle	1
30	Spring	1	78	Seat	1	128	Blade Height Wheel	1
31	Guard	1	80	Fixing Plate	1	129	Rocker	1
32	Plate	1	81	Lifting Nut	1	130	Bolt M6x12	7
33	Screw ST4.2x10	6	82	Gear Box	1	131	Seat	1
34	Bolt M6x16	6	83	Screw M5 X 40 (Set)	4	132	Sleeve	1
35	Bolt M6x16	2	84	Shroud	1	133	Fixing Base	1
36	Rotating Seat	1	85	Screw St4.2x 65	2	134	Base	1
38	Guard Fixing Plate	1	86	Stator	1	135	Cap	1
39	Screw	4	87	Bearing 609(Z3)	1	136	Plate	1
40	Blade Guard Left	1	88	Armature	1	137	Cap	1
41	Nut M5	4	89	Bearing 6001(Z3)	1	138	Bolt	2
42	Washer 5x14x1	1	90	Motor Housing	1	139	Rotary Knob	1
43	Tigger	1	91	Washer	1	140	Miter Gauge	1
44	Support Base	1	92	Connector Wire	1	141	Guide Bar	1
45	Riving Knife	1	93	Screw St4.2x 16	7	142	Push Rod	1
46	Spring	1	94	Clamp	2	143	Wrench	2
47	Pin	1	95	Brush Holder	2			
48	Locknut	1	96	Brush Cap	2			

# Assembly Diagram

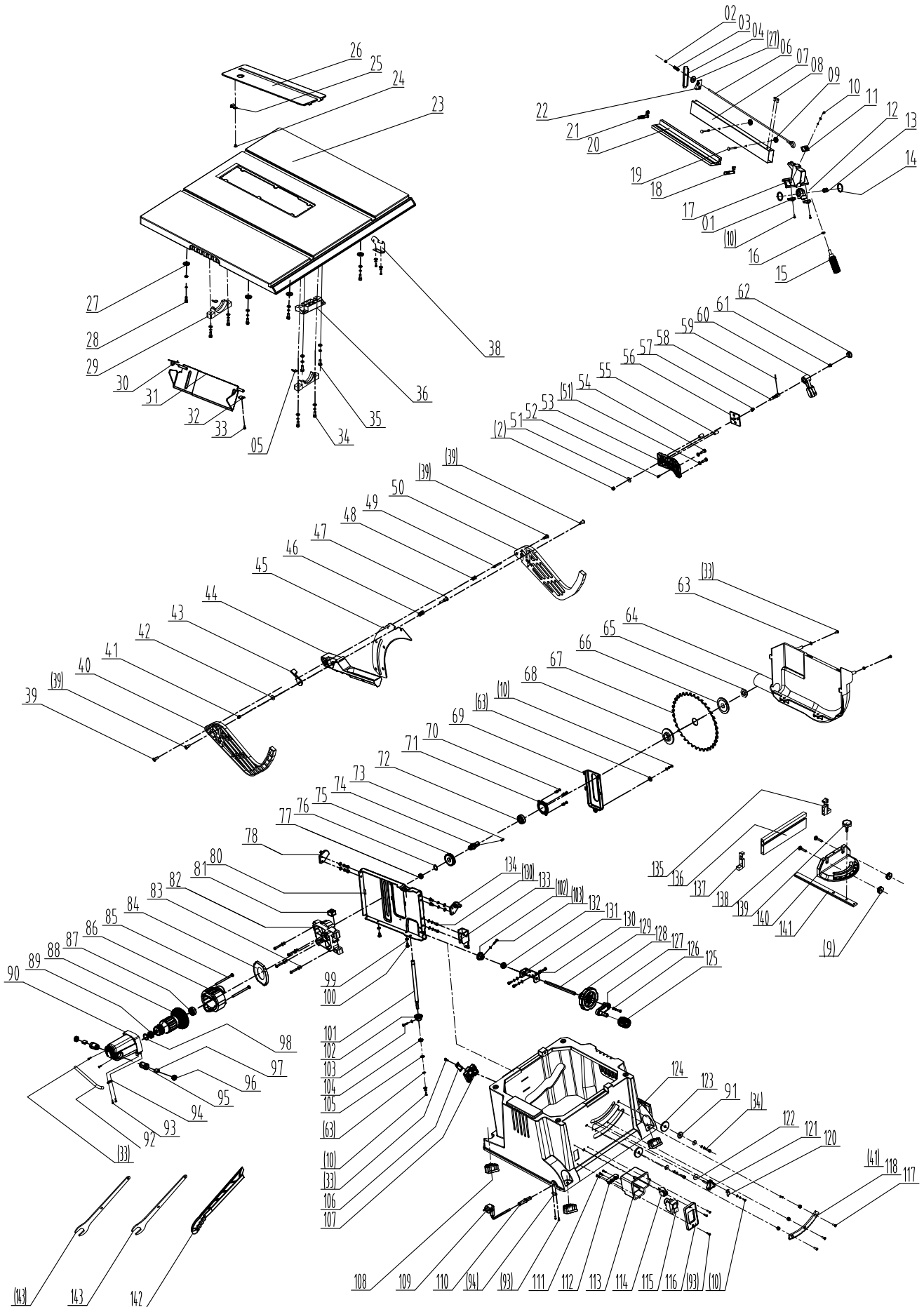

SAFETY

SETUP

OPERATION

MAINTENANCE

## Limited 90 Day Warranty

Harbor Freight Tools Co. makes every effort to assure that its products meet high quality and durability standards, and warrants to the original purchaser that this product is free from defects in materials and workmanship for the period of 90 days from the date of purchase. This warranty does not apply to damage due directly or indirectly, to misuse, abuse, negligence or accidents, repairs or alterations outside our facilities, criminal activity, improper installation, normal wear and tear, or to lack of maintenance. We shall in no event be liable for death, injuries to persons or property, or for incidental, contingent, special or consequential damages arising from the use of our product. Some states do not allow the exclusion or limitation of incidental or consequential damages, so the above limitation of exclusion may not apply to you. THIS WARRANTY IS EXPRESSLY IN LIEU OF ALL OTHER WARRANTIES, EXPRESS OR IMPLIED, INCLUDING THE WARRANTIES OF MERCHANTABILITY AND FITNESS.

To take advantage of this warranty, the product or part must be returned to us with transportation charges prepaid. Proof of purchase date and an explanation of the complaint must accompany the merchandise. If our inspection verifies the defect, we will either repair or replace the product at our election or we may elect to refund the purchase price if we cannot readily and quickly provide you with a replacement. We will return repaired products at our expense, but if we determine there is no defect, or that the defect resulted from causes not within the scope of our warranty, then you must bear the cost of returning the product.

This warranty gives you specific legal rights and you may also have other rights which vary from state to state.



26541 Agoura Road • Calabasas, CA 91302 • 1-888-866-5797