

Owner's Manual & Safety Instructions

Save This Manual Keep this manual for the safety warnings and precautions, assembly, operating, inspection, maintenance and cleaning procedures. Write the product's serial number in the back of the manual (or month and year of purchase if product has no number). Keep this manual and the receipt in a safe and dry place for future reference.

22c

PITTSBURGH[®] AUTOMOTIVE

64499
58661
58662
58663

275 LB. CAPACITY ADJUSTABLE SHOP STOOL WITH BACKREST



Visit our website at: <http://www.harborfreight.com>
Email our technical support at: productsupport@harborfreight.com

When unpacking, make sure that the product is intact and undamaged. If any parts are missing or broken, please call 1-888-866-5797 as soon as possible.

Copyright© 2021 by Harbor Freight Tools®. All rights reserved.

No portion of this manual or any artwork contained herein may be reproduced in any shape or form without the express written consent of Harbor Freight Tools. Diagrams within this manual may not be drawn proportionally. Due to continuing improvements, actual product may differ slightly from the product described herein.

Tools required for assembly and service may not be included.

⚠ WARNING

Read this material before using this product. Failure to do so can result in serious injury. **SAVE THIS MANUAL.**

Specifications

Maximum Weight Capacity	275 lb
Seat Height Range	~29-3/4" to ~34-1/2"
Item	Color
64499	Black
58661	Blue
58662	Red
58663	Green

IMPORTANT SAFETY INFORMATION

Assembly Precautions

1. Assemble only according to these instructions. Improper assembly can create hazards.
2. Wear ANSI-approved safety goggles and heavy-duty work gloves during assembly.
3. Keep assembly area clean and well lit.
4. Keep bystanders out of the area during assembly.
5. Do not assemble when tired or when under the influence of alcohol, drugs or medication.
6. Weight capacity and other product capabilities apply to properly and completely assembled product only.

Use Precautions

1. This product is not a toy. Do not allow children to play with or near this item.
2. Use as intended only.
3. Inspect before every use; do not use if parts are loose or damaged.
4. Do not exceed weight capacity of 275 lb. Be aware of dynamic loading! Sudden dropping into the seat may briefly create excess load causing product failure.
5. Maintain product labels and nameplates. These carry important safety information. If unreadable or missing, contact Harbor Freight Tools for a replacement.
6. When not in use, this product must be stored in a dry location to inhibit rust.
7. When servicing, use only identical replacement parts.
8. Do not use the seat as a step stool.
9. During use, do not place your feet or legs inside the Large Rings or Legs. The exposed Bolt threads may scratch or catch on clothing.
10. The warnings, cautions, and instructions discussed in this instruction manual cannot cover all possible conditions and situations that may occur. It must be understood by the operator that common sense and caution are factors which cannot be built into this product, but must be supplied by the operator.

PLEASE READ THE FOLLOWING CAREFULLY

THE MANUFACTURER AND/OR DISTRIBUTOR HAS PROVIDED THE PARTS LIST AND ASSEMBLY DIAGRAM IN THIS DOCUMENT AS A REFERENCE TOOL ONLY. NEITHER THE MANUFACTURER OR DISTRIBUTOR MAKES ANY REPRESENTATION OR WARRANTY OF ANY KIND TO THE BUYER THAT HE OR SHE IS QUALIFIED TO MAKE ANY REPAIRS TO THE PRODUCT, OR THAT HE OR SHE IS QUALIFIED TO REPLACE ANY PARTS OF THE PRODUCT. IN FACT, THE MANUFACTURER AND/OR DISTRIBUTOR EXPRESSLY STATES THAT ALL REPAIRS AND PARTS REPLACEMENTS SHOULD BE UNDERTAKEN BY CERTIFIED AND LICENSED TECHNICIANS, AND NOT BY THE BUYER. THE BUYER ASSUMES ALL RISK AND LIABILITY ARISING OUT OF HIS OR HER REPAIRS TO THE ORIGINAL PRODUCT OR REPLACEMENT PARTS THERETO, OR ARISING OUT OF HIS OR HER INSTALLATION OF REPLACEMENT PARTS THERETO.

Assembly Instructions



Read the **ENTIRE IMPORTANT SAFETY INFORMATION** section at the beginning of this document including all text under subheadings therein before set up or use of this product.

NOTE: When assembling the leg/base section of the Stool, all of the Bolts should have their heads facing outside, with all of the Nuts on the inside of the frame.

NOTE: The Stool should be assembled and used on a flat, level, dry surface. Refer to the Assembly Diagram during assembly.

1. Attach a Leg (11) to the Bracket aligning the holes. Slide the Connector Cover (6) all the way down to secure the Leg (11) into a groove. Insert a Long Bolt (5) through the aligned hole.
2. Hold Long Bolt (5) in place and turn the Bracket over so the threads of the Bolt are facing up. Place the Connector Plate (10) through the Bolt and fasten with Locking Nut (8).
3. Repeat for all four Legs. Finger tighten Nuts.
4. Turn the Stool over onto its four Legs.
5. Place the Large Ring (12) INSIDE all four Legs (11) and align the holes. Insert a Bolt (9) through each aligned hole and fasten with Locking Nut (8). Finger tighten Nuts.
6. Place the Small Ring (7) OUTSIDE all four Legs (11) and align the holes. Insert a Bolt (9) through each aligned hole and fasten with Locking Nut (8). Finger tighten Nuts.

7. Once both Rings are attached, go back and completely tighten all Nuts on Rings (7, 12), Legs (11), Connector Cover (6) and Connector Plate (10). Make sure the Connector Cover grooves are pushed down around each Leg.
8. Slide the Hydraulic Cylinder (4) into the Bracket with its spindle facing up. See diagram below.
9. Place the Seat (2) over the Hydraulic Cylinder (4) and press down firmly so its metal plate attaches to the Cylinder spindle. Ensure it is secure to the Cylinder.
10. Place the two Back Supports (3) onto the back of the Seat (2).

NOTE: The Supports can only be inserted from one direction. Loosen the two knobs under the Seat before inserting. Retighten the knobs after Back Rest (1) is adjusted.

11. Slide the Back Rest (1) on the Back Supports (3).

NOTE: The push buttons must be pressed before the Back Rest will slide all the way down. When aligned, the buttons will pop out of the holes locking the Back Rest in place.

12. Go back and completely tighten all fasteners.

Parts List and Assembly Diagram

Part	Description	Qty
1	Back Rest	1
2	Seat	1
3	Back Support	2
4	Hydraulic Cylinder	1
5	Long Bolt M6	4
6	Connector Cover	1
7	Small Ring	1
8	M6 Locking Nut	12
9	Bolt M6	8
10	Connector Plate	1
11	Leg	4
12	Large Ring	1

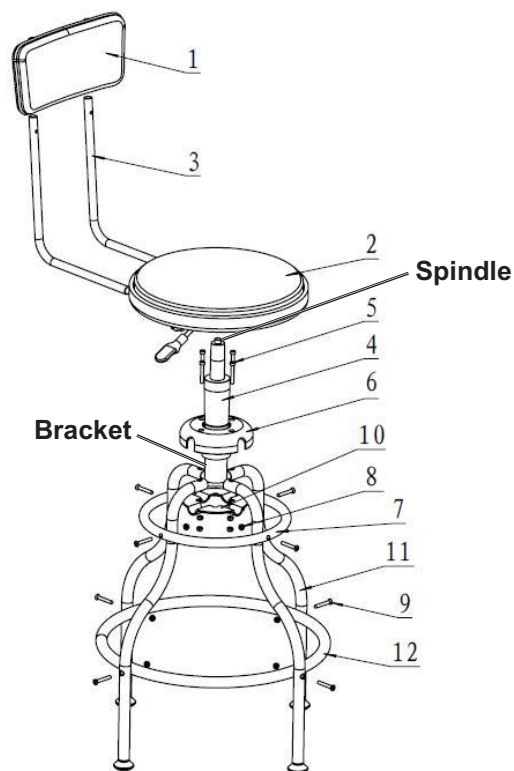

Limited 90 Day Warranty

Harbor Freight Tools Co. makes every effort to assure that its products meet high quality and durability standards, and warrants to the original purchaser that this product is free from defects in materials and workmanship for the period of 90 days from the date of purchase. This warranty does not apply to damage due directly or indirectly, to misuse, abuse, negligence or accidents, repairs or alterations outside our facilities, criminal activity, improper installation, normal wear and tear, or to lack of maintenance. We shall in no event be liable for death, injuries to persons or property, or for incidental, contingent, special or consequential damages arising from the use of our product. Some states do not allow the exclusion or limitation of incidental or consequential damages, so the above limitation of exclusion may not apply to you. THIS WARRANTY IS EXPRESSLY IN LIEU OF ALL OTHER WARRANTIES, EXPRESS OR IMPLIED, INCLUDING THE WARRANTIES OF MERCHANTABILITY AND FITNESS.

To take advantage of this warranty, the product or part must be returned to us with transportation charges prepaid. Proof of purchase date and an explanation of the complaint must accompany the merchandise. If our inspection verifies the defect, we will either repair or replace the product at our election or we may elect to refund the purchase price if we cannot readily and quickly provide you with a replacement. We will return repaired products at our expense, but if we determine there is no defect, or that the defect resulted from causes not within the scope of our warranty, then you must bear the cost of returning the product.

This warranty gives you specific legal rights and you may also have other rights which vary from state to state.

PITTSBURGH[®] AUTOMOTIVE

Record Serial Number Here:

Note: If product has no serial number, record month and year of purchase instead.

Note: Some parts are listed and shown for illustration purposes only, and are not available individually as replacement parts. Parts may not be interchangeable.

Specify UPC number when ordering:

Black: 792363644990

Blue: 193175443465

Red: 193175443472

Green: 193175443489