

# Owner's Manual & Safety Instructions

Save This Manual Keep this manual for the safety warnings and precautions, assembly, operating, inspection, maintenance and cleaning procedures. Write the product's serial number in the back of the manual (or month and year of purchase if product has no number). Keep this manual and the receipt in a safe and dry place for future reference.

221

# PITTSBURGH™

## 1 TON FOLDABLE SHOP CRANE



Item	58794
Weight Capacity	1 Ton (2,000 lb.)
Maximum Height	85-7/8"
Minimum Height	12-1/2"

Visit our website at: <http://www.harborfreight.com>  
Email our technical support at: [productsupport@harborfreight.com](mailto:productsupport@harborfreight.com)

When unpacking, make sure that the product is intact and undamaged. If any parts are missing or broken, please call 1-888-866-5797 as soon as possible.

Copyright© 2022 by Harbor Freight Tools®. All rights reserved.  
No portion of this manual or any artwork contained herein may be reproduced in any shape or form without the express written consent of Harbor Freight Tools. Diagrams within this manual may not be drawn proportionally. Due to continuing improvements, actual product may differ slightly from the product described herein. Tools required for assembly and service may not be included.

### ⚠ WARNING





Read this material before using this product.  
Failure to do so can result in serious injury.  
**SAVE THIS MANUAL.**

# Table of Contents

Safety.....	2	Maintenance .....	8
Specifications.....	4	Parts Lists and Diagrams.....	10
Setup .....	4	Warranty .....	12
Operation .....	7		

# PITTSBURGH™

## WARNING SYMBOLS AND DEFINITIONS

	This is the safety alert symbol. It is used to alert you to potential personal injury hazards. Obey all safety messages that follow this symbol to avoid possible injury or death.
	Indicates a hazardous situation which, if not avoided, will result in death or serious injury.
	Indicates a hazardous situation which, if not avoided, could result in death or serious injury.
	Indicates a hazardous situation which, if not avoided, could result in minor or moderate injury.
	Addresses practices not related to personal injury.

## IMPORTANT SAFETY INFORMATION

### General Safety Warnings

1. Study, understand, and follow all instructions before operating this device.
2. Do not exceed rated capacity.
3. Use only on hard, level surface capable of supporting the load.
4. Before moving, lower the load to the lowest possible height.
5. Failure to heed these markings may result in personal injury and/or property damage.
6. Use only sling or chains with a rated capacity greater than the weight of the load being lifted.
7. Do not allow load to swing or drop violently while lowering or moving.
8. No alterations shall be made to this product. Do not adjust safety valve.
9. Properly extend leg extensions and secure boom in proper setting before use.
10. Follow capacities marked on boom; capacity decreases as boom lengthens.
11. Wear ANSI-approved safety goggles and heavy-duty work gloves during use.
12. Verify replacement ram has same rating, mounting points and maximum length.
13. Do not use for aircraft purposes.
14. Inspect before every use; do not use if parts loose or damaged.
15. Keep your work area clean and well lit. Cluttered work areas invite accidents.
16. Keep bystanders, children, and visitors away while operating Engine Crane. Distractions can cause you to lose control.
17. Stay alert. Watch what you are doing, and use common sense when operating a ram. Do not use a ram while tired or under the influence of drugs, alcohol, or medication. A moment of inattention while operating rams may result in serious personal injury.

18. Follow instructions in the "Inspection, Maintenance, And Cleaning" section of this manual. Use of unauthorized parts or failure to follow maintenance instructions may create a risk of injury and may void any applicable warranty.
19. Maintain labels and nameplates on the Engine Crane. These carry important information. If unreadable or missing, contact Harbor Freight Tools for a replacement.
20. Before use, read manufacturer's instruction manual for the object you will lift.
21. Industrial applications must follow OSHA requirements.
22. The warnings, precautions, and instructions discussed in this manual cannot cover all possible conditions and situations that may occur. The operator must understand that common sense and caution are factors, which cannot be built into this product, but must be supplied by the operator.



**SAVE THESE INSTRUCTIONS.**

## Specifications

Specifications	
Ram Capacity	3 Ton

Boom Positions	
1 Ton	76-3/4"
3/4 Ton	79-3/4"
1/2 Ton	82-7/8"
1/4 Ton	85-7/8"

## Package Contents

Box A		
Part	Description	Qty
29	Leg	2
21	Support Brace	2
22	Support Post	1
23	Boom	1
24	Boom Extension	1
25	Ram	1
27	Ram Handle	1

Box B		
Part	Description	Qty
28	Base	1
	Assembly Hardware and Casters	Lot

## Assembly

### Bolt Shaft Identification Chart

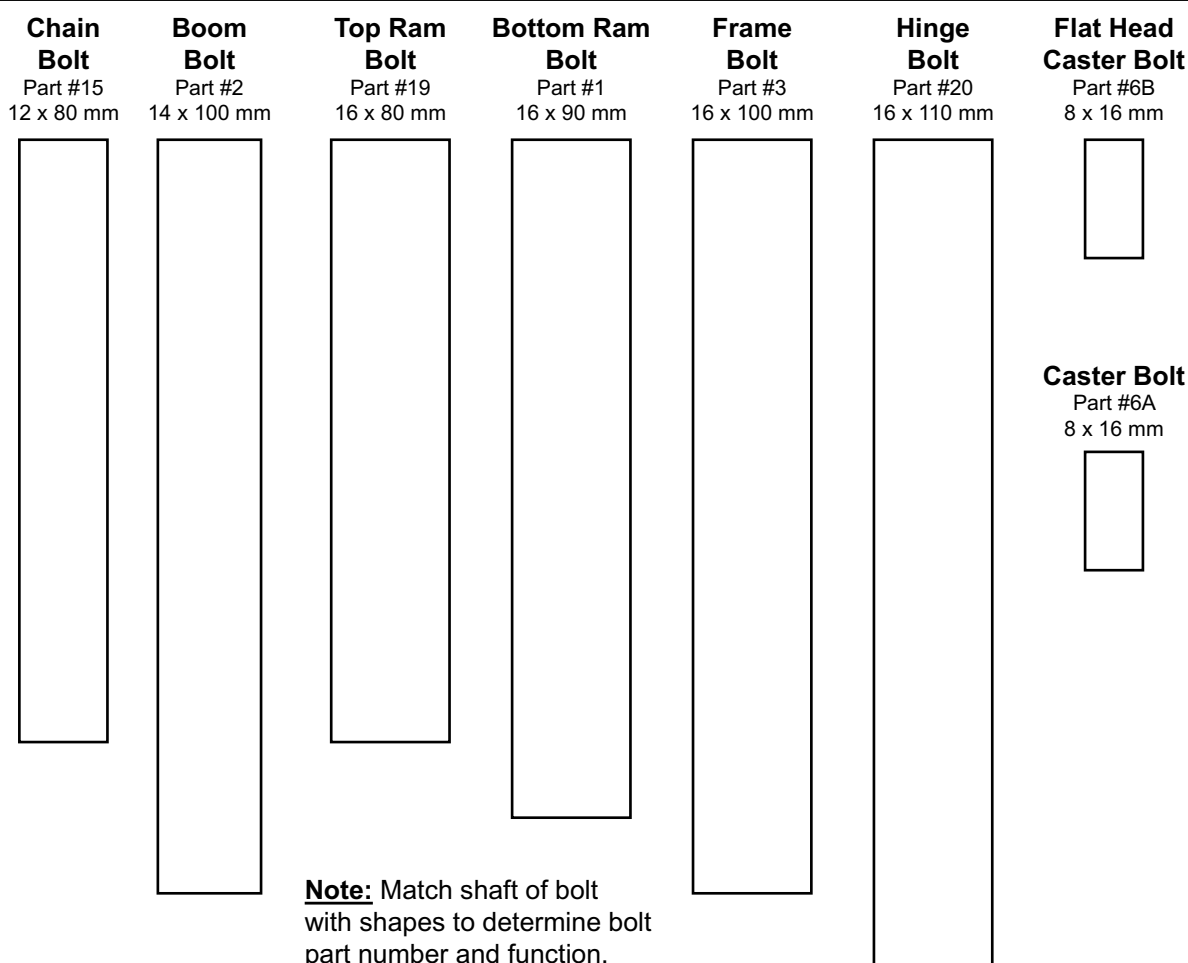

### **⚠ WARNING**

**TO PREVENT SERIOUS INJURY AND DEATH:**

The correct bolts must be used during assembly. Carefully compare bolts to Bolt Identification illustration above and the measurements shown in the parts list and assembly diagrams near the end of this manual to make sure that the correct bolts are used in the correct place.

For safety and ease of assembly, use two people to assemble the Shop Crane.

**NOTICE:** DO NOT TIGHTEN ANY BOLTS UNTIL YOU ARE FULLY FINISHED WITH ASSEMBLY. OTHERWISE PARTS WILL NOT LINE UP PROPERLY.

1. Attach the two 3-1/2" Brake Casters(31) to the Base(28) by aligning the four mounting holes in each 3-1/2" Brake Caster(31) with the four mounting holes on the underside of each Base(28) end. Secure them in place using four Caster Bolts(6A), Lock Washers(8), and Nuts(9). See Figure A.
2. Attach the two 3" Casters(10) to the Base(28) by aligning the four mounting holes in each 3" Caster(10) with the four mounting holes on the underside of each Base(28) end. Secure them in place using four Flat Head Caster Bolts(6B), Lock Washers(8), and Nuts(9). See Figure A.

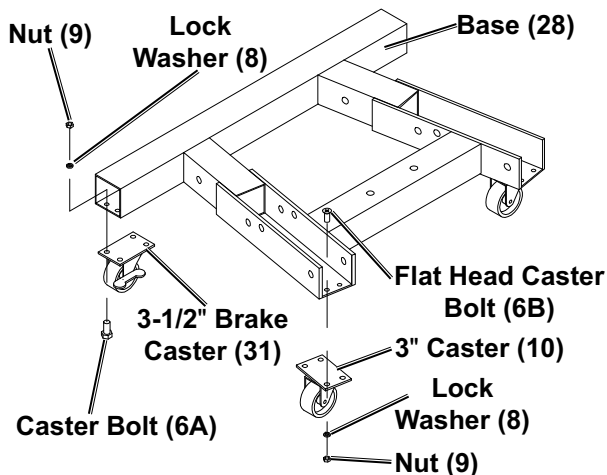

Figure A

3. Attach a 3-1/2" Caster(7) to each Leg(29) by aligning the four mounting holes in each 3-1/2" Caster(7) with the four mounting holes on the underside of each Leg(29). Secure them in place using four Caster Bolts(6A), Lock Washers(8), and Nuts(9). See Figure B.
4. Place a Slider(32) on each Leg(29), making sure the ring is facing out as illustrated. Secure each Leg(29) to the Base with two Leg Pins(11). After all four Leg Pins(11) are inserted, insert one R-Pin(14) through the small hole at the end of each Leg Pin(11) until it snaps into place. See Figure B.

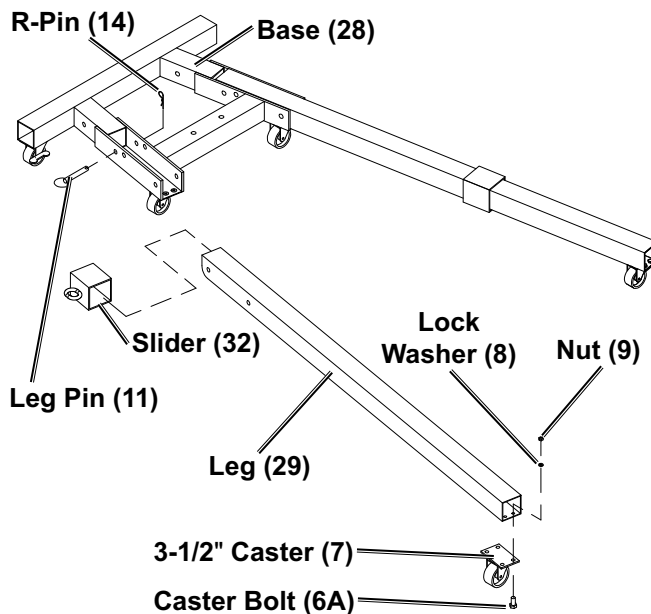

Figure B

**Note:** Make sure Leg Pins(11) and R-Pins(14) are secure before proceeding.

5. Mount the Support Post(22) to the Base(28) with the two Boom Bolts(2), Washers(12), and Nuts(13). See Figure C.
6. Mount the two Support Braces(21) to the Support Post(22) with a Hinge Bolt(20), Washer(4), and Nut(5), and to the Base(28) with Frame Bolts(3), Washers(12) and Nuts(13). See Figure C.

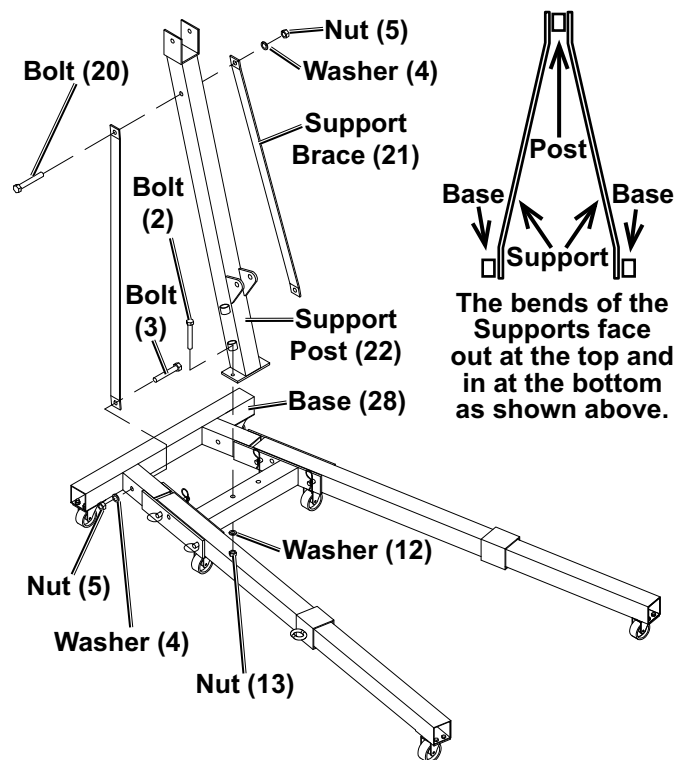

Figure C

7. Mount the Boom(23) to the Support Post(22) with a Hinge Bolt(20), Washer(4), and Nut(5). See Figure D.
8. Attach the Ram(25) to the underside of the Boom(23) with the Top Ram Bolt(19) Washer(4), and Nut(5). See Figure D.
9. Attach the Ram(25) to the Support Post(22) with the Bottom Ram Bolt(1) Washer(4), and Nut(5). See Figure D.
10. Attach the Ram Handle(27) to the Ram(25). See Figure D.

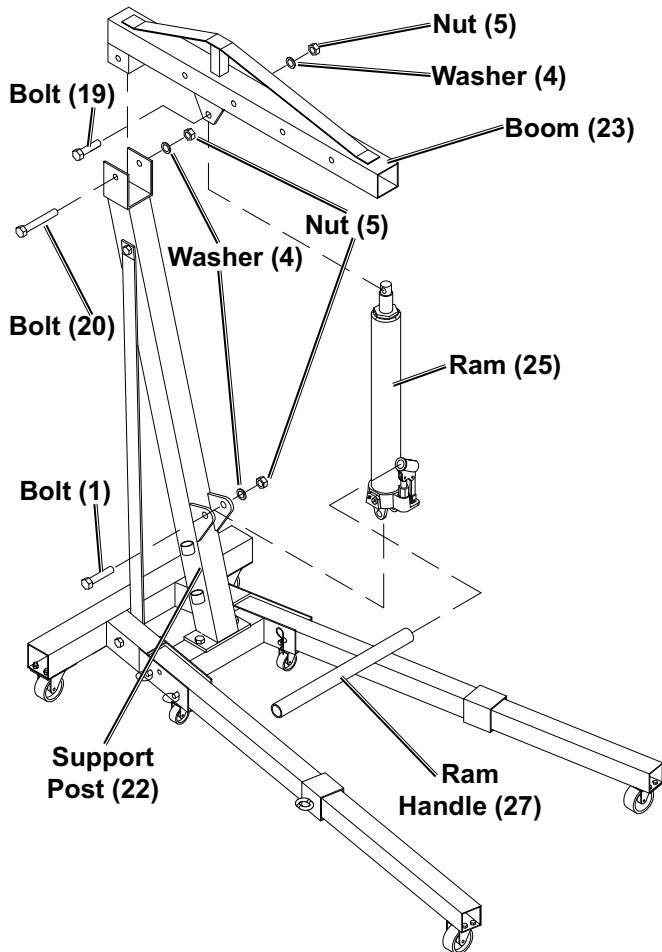

Figure D

11. Slide the Boom Extension(24) into the Boom (23) to the desired rating, and secure in place with the Boom Pin(30). insert one R-Pin(14) through the small hole at the end of the Boom Pin(30) until it snaps into place. See Figure E.
12. Attach the Chain / Hook(26) to the Boom Extension(24) with the Chain Bolt(15), Washer(16), Lock Washer(17), and Nut(18). See Figure E.

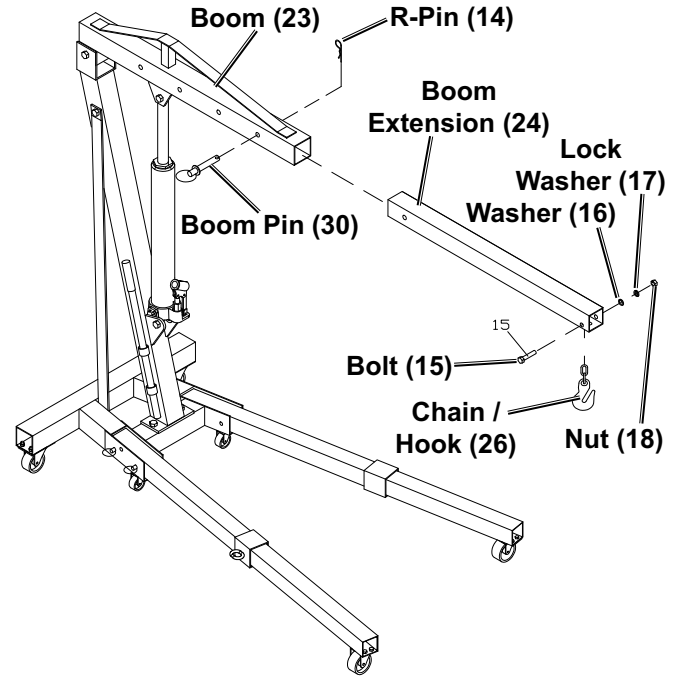

Figure E

**NOTICE:** TIGHTEN ALL BOLTS AND NUTS ONLY AFTER ALL ASSEMBLY HAS BEEN COMPLETED.

## Operating Instructions



Read **ENTIRE IMPORTANT SAFETY INFORMATION** section at beginning of this manual including all text under subheadings therein before set up or use of this product.

**Note:** Once Assembly is complete, tighten ALL Bolts before initial operation.

### Lifting and Lowering

1. Locate the hole on the Boom with a weight limit higher than the weight you will be lifting.  
**For example: Locate the 1/2 TON hole on the Boom for a load that is under 1/2 Ton. See Figure F.**
2. Adjust the Boom Extension(24) so the hole farthest from the hook-end aligns with the chosen hole on the Boom(23). Secure into place by inserting the Boom Pin(30) through all aligned holes and securing in place with the R-Pin(14). See Figure F.

**WARNING!** Keep clear of the object that is being lifted by the Shop Crane. Be aware of the possibility of a load slipping off the Hook and Chain. An item that falls from the Crane can cause serious injury.

3. Move the Shop Crane so that the Chain / Hook(26) are directly above the Load to be lifted. See Figure F.
4. Securely attach the Chain / Hook(26) to the Load. See Figure F.

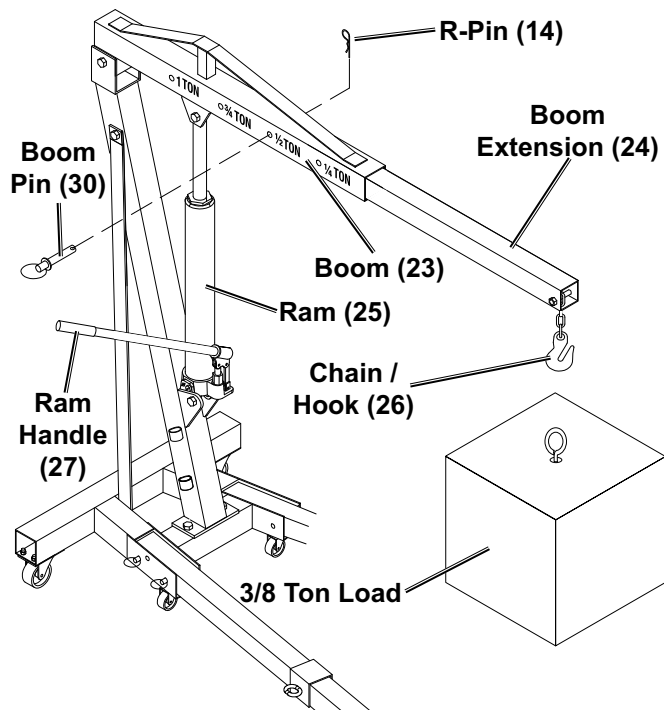

Figure F

5. To raise the Boom, turn the Ram's Release Valve(7A) fully clockwise (right). Insert the Ram Handle(27) into the Ram(25) and pump (up and down) repeatedly until the Load has been lifted to the desired height. See Figure G.

**Note:** Fully tighten the Release Valve(7A) or else the Ram(25) may lower or may not be able to reach the full height.

6. To lower the Shop Crane, **SLOWLY** turn the Release Valve(7A) counterclockwise (left). See Figure G.

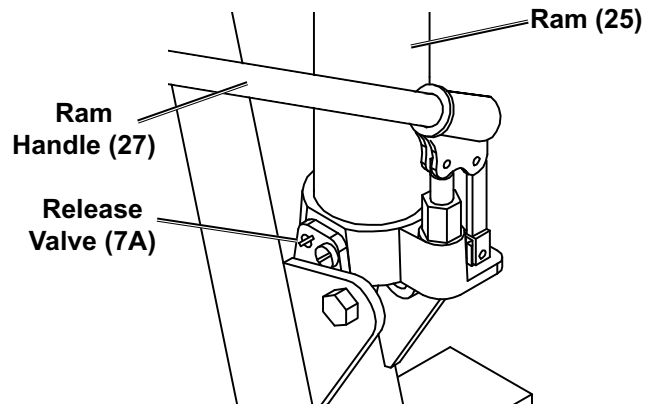

Figure G

### Folding the Frame

**WARNING!** Do not fold the Shop Crane while loaded.

1. Lower the Shop Crane by turning the Release Valve(7A) counterclockwise (left). See Figure H.
2. Remove R-Pins(14) from the front Leg Pins(11). Remove the front Leg Pins(11). Leave rear Leg Pins(11) in. See Figure H.
3. Raise the Legs until they rest against the Ram Handle(27). Insert a front Leg Pin(11) into the middle hole of the Base(25), for each Leg(29), and reinsert R-Pins(14). See Figure H.

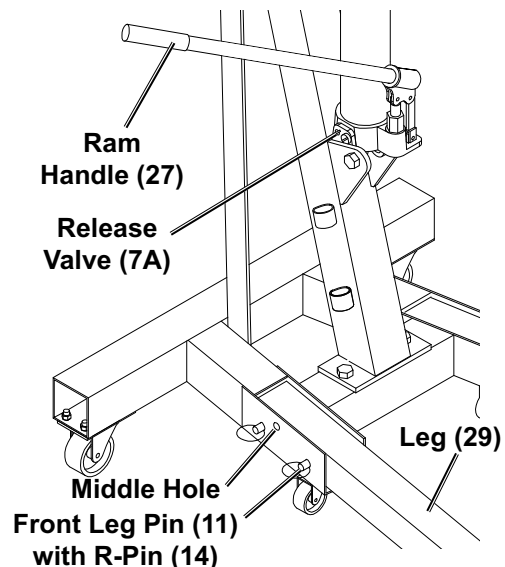

Figure H

## Bleeding Instructions

**IMPORTANT!** Before first use, check for proper hydraulic oil level and thoroughly test the equipment. If it does not work properly, bleed excess air from its hydraulic system as follows:

1. Open the Release Valve(7A) and lower the Ram(25) completely. See Figure I.
2. Remove Oil Plug(26A) and fill with hydraulic oil (sold separately) to full level. See Figure I.
3. Apply downward pressure to the Boom(23) and Pump the Ram Handle(27) quickly several times. See Figure I.
4. Check the Oil Fill Hole and, if necessary, top off the Oil Fill Hole with hydraulic oil. See Figure I.
5. Replace the Oil Plug(26A) and close the Release Valve(7A). See Figure I.

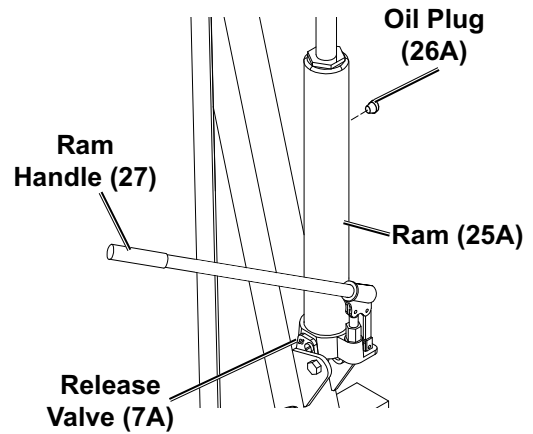

Figure A

6. Test the equipment several times for proper operation before attempting to lift a load. If, after bleeding, the equipment still does not appear to be working properly, do not use the equipment until it has been repaired by a qualified service technician.

## Maintenance and Servicing



Procedures not specifically explained in this manual must be performed only by a qualified technician.

### **WARNING**

**TO PREVENT SERIOUS INJURY FROM ACCIDENTAL OPERATION:**  
Do not use damaged equipment. If abnormal noise or vibration occurs, have the problem corrected before further use.

## Cleaning, Maintenance, and Lubrication

1. **BEFORE EACH USE**, inspect the general condition of the tool. Check for:
  - loose hardware,
  - misalignment or binding of moving parts,
  - cracked or broken parts, and
  - any other condition that may affect its safe operation.
2. **Before each use, thoroughly test the Ram(25) for proper operation prior to its actual use. If the Ram(25) appears to *not* be working properly, follow *Bleeding* instructions on page 8.**
3. **Change the hydraulic oil at least once every three years:**
  - a. With the Ram(25) fully lowered, remove the Oil Plug(26A) on the side of the Oil Tank(25A).
  - b. Tip the Ram(25) to allow the old hydraulic oil to drain out of the Oil Tank(25A) completely, and dispose of the old hydraulic oil in accordance with local regulations.
  - c. With the Ram(25) upright, completely fill the Oil Tank(25A) with a high quality hydraulic oil (not included) until the oil just begins to run out of the Oil Fill Hole.
  - d. Open the Release Valve(7A) and pump the Ram Handle(27) to bleed air from the system.
  - e. Reinstall the Oil Plug(26A).
4. Wipe dry with a clean cloth. Then, store the Shop Crane in a safe, dry location out of reach of children and other non-authorized people.



## Troubleshooting

**⚠ WARNING** TO PREVENT SERIOUS INJURY: Use caution when troubleshooting malfunctioning ram. Stay clear of supported load. Completely resolve all problems before use.

If solutions presented in Troubleshooting guide do not solve the problem, have a qualified technician inspect and repair ram before use. **After ram is repaired: Test it carefully without a load by raising and lowering it fully, checking for proper operation, BEFORE RETURNING RAM TO OPERATION.**

**DO NOT USE A DAMAGED OR MALFUNCTIONING RAM!**

POSSIBLE SYMPTOMS						PROBABLE SOLUTION (Make certain that the Ram is not supporting a load while attempting a solution.)
Ram will not lift at its weight capacity	Boom lowers under load	Pump stroke feels spongy	Boom will not lift all the way	Handle moves up when Ram is under load	Oil leaking from Filler Plug	
X	X					Check that Release Valve is closed fully. Bleed air from the system.
X	X			X		Valves may be blocked and may not close fully. To flush the valves: 1. Lower the Chain / Hook and securely close the Release Valve. 2. Manually lift the Chain / Hook several inches. 3. Open the release valve and force the Chain / Hook down as quickly as possible.
X		X	X			Ram may be low on oil. Check the oil level and refill if needed. Ram may require bleeding - see instructions on page 9.
					X	Unit may have too much hydraulic oil inside, check fluid level and adjust if needed.

## PLEASE READ THE FOLLOWING CAREFULLY

THE MANUFACTURER AND/OR DISTRIBUTOR HAS PROVIDED THE PARTS LIST AND ASSEMBLY DIAGRAM IN THIS MANUAL AS A REFERENCE TOOL ONLY. NEITHER THE MANUFACTURER OR DISTRIBUTOR MAKES ANY REPRESENTATION OR WARRANTY OF ANY KIND TO THE BUYER THAT HE OR SHE IS QUALIFIED TO MAKE ANY REPAIRS TO THE PRODUCT, OR THAT HE OR SHE IS QUALIFIED TO REPLACE ANY PARTS OF THE PRODUCT. IN FACT, THE MANUFACTURER AND/OR DISTRIBUTOR EXPRESSLY STATES THAT ALL REPAIRS AND PARTS REPLACEMENTS SHOULD BE UNDERTAKEN BY CERTIFIED AND LICENSED TECHNICIANS, AND NOT BY THE BUYER. THE BUYER ASSUMES ALL RISK AND LIABILITY ARISING OUT OF HIS OR HER REPAIRS TO THE ORIGINAL PRODUCT OR REPLACEMENT PARTS THERETO, OR ARISING OUT OF HIS OR HER INSTALLATION OF REPLACEMENT PARTS THERETO.

# Crane Parts List and Diagram

Part	Description	Qty
1	Bottom Ram Bolt M16x90	1
2	Boom Bolt M14x100	2
3	Frame Bolt M16x100	2
4	M16 Washer	6
5	M16 Nut	6
6A	Caster Bolt M8x16	16
6B	Flat Head Caster Bolt M8x16	8
7	3-1/2" Caster	2
8	M8 Lock Washer	24
9	M8 Nut	24
10	3" Caster	2

Part	Description	Qty
11	Leg Pin	4
12	M14 Washer	2
13	M14 Nut	2
14	R-Pinz	5
15	Chain Bolt M12x80	1
16	M12 Washer	1
17	M12 Lock Washer	1
18	M12 Nut	1
19	Top Ram Bolt M16x80	1
20	Hinge Bolt M16x110	2
21	Support Brace	2

Part	Description	Qty
22	Support Post	1
23	Boom	1
24	Boom Extension	1
25	Ram	1
26	Chain / Hook	1
27	Ram Handle	1
28	Base	1
29	Leg	2
30	Boom Pin	1
31	3-1/2" Brake Caster	2
32	Slider	2

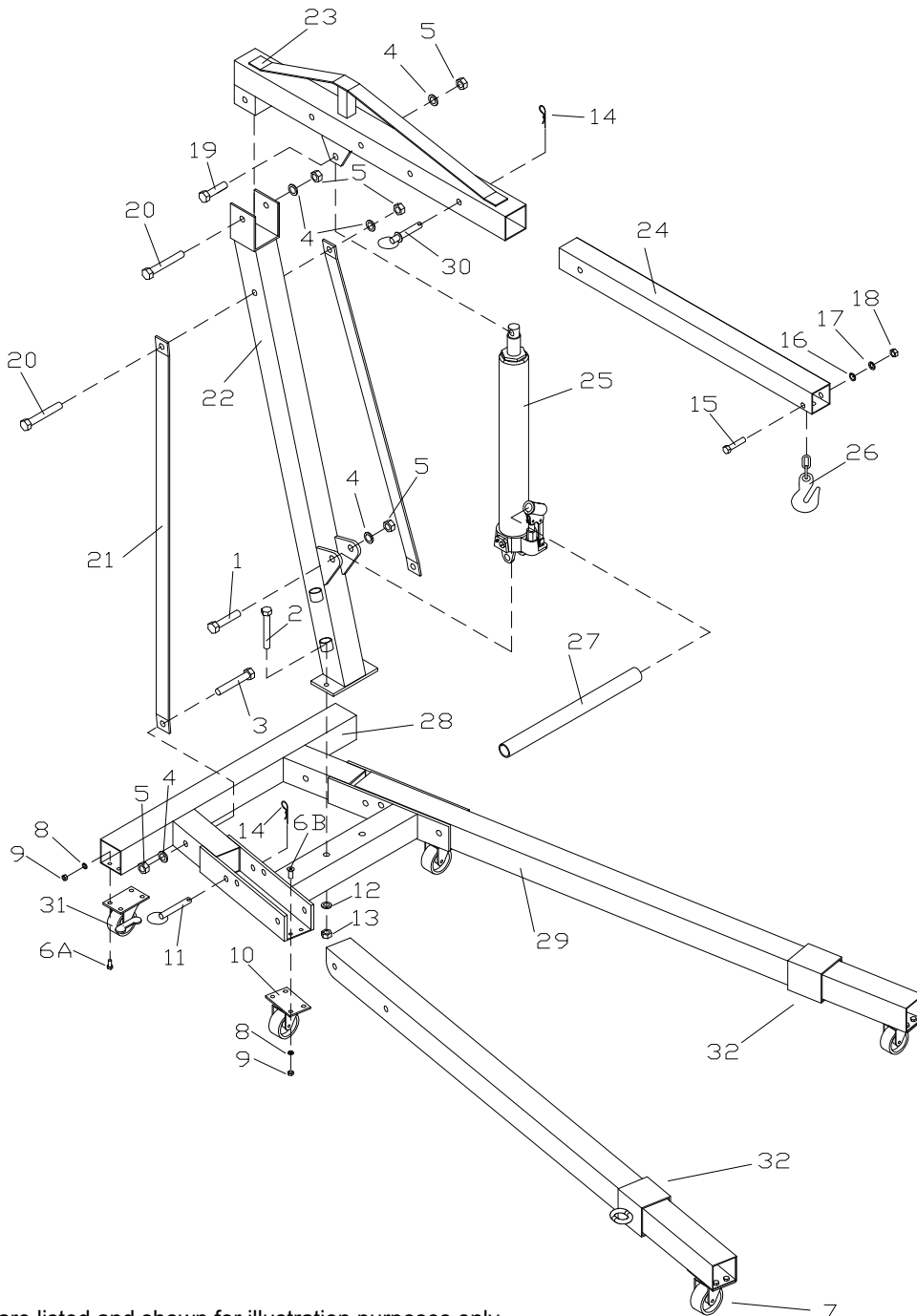

**Note:** Some parts are listed and shown for illustration purposes only, and are not available individually as replacement parts. Specify UPC 193175446725 when ordering parts.

SAFETY

SETUP

OPERATION

MAINTENANCE

# Ram Parts List and Diagram

Part	Description	Qty
1A	Screw	1
2A	O-Ring	1
3A	Spring	1
4A	Ball Cup	1
5A	Steel Ball	1
6A	Screw Cover	1
7A	Release Valve	1
8A	Rectangle Seal Ring	1
9A	Steel Ball	1
10A	Base	1
11A	Pin	2

Part	Description	Qty
12A	Pin	1
13A	Pin Shaft	2
14A	Connecting Bar	1
15A	Handle Sleeve	1
16A	Steel Ball	2
17A	Washer	1
18A	O-Ring	1
19A	Shield Ring	1
20A	Pump Core	1
21A	Washer	1
22A	Hydraulic Cylinder	1

Part	Description	Qty
23A	Pump Body	1
24A	Seal Ring	1
25A	Oil Tank	1
26A	Oil Plug	1
27A	Rectangle Seal Ring	1
28A	O-Ring	1
29A	Top Nut	1
30A	O-ring	1
31A	Bowl Washer	1
32A	Piston Rod	1

**Note:** When re-ordering parts from this list, use the part number with the "A" suffix.

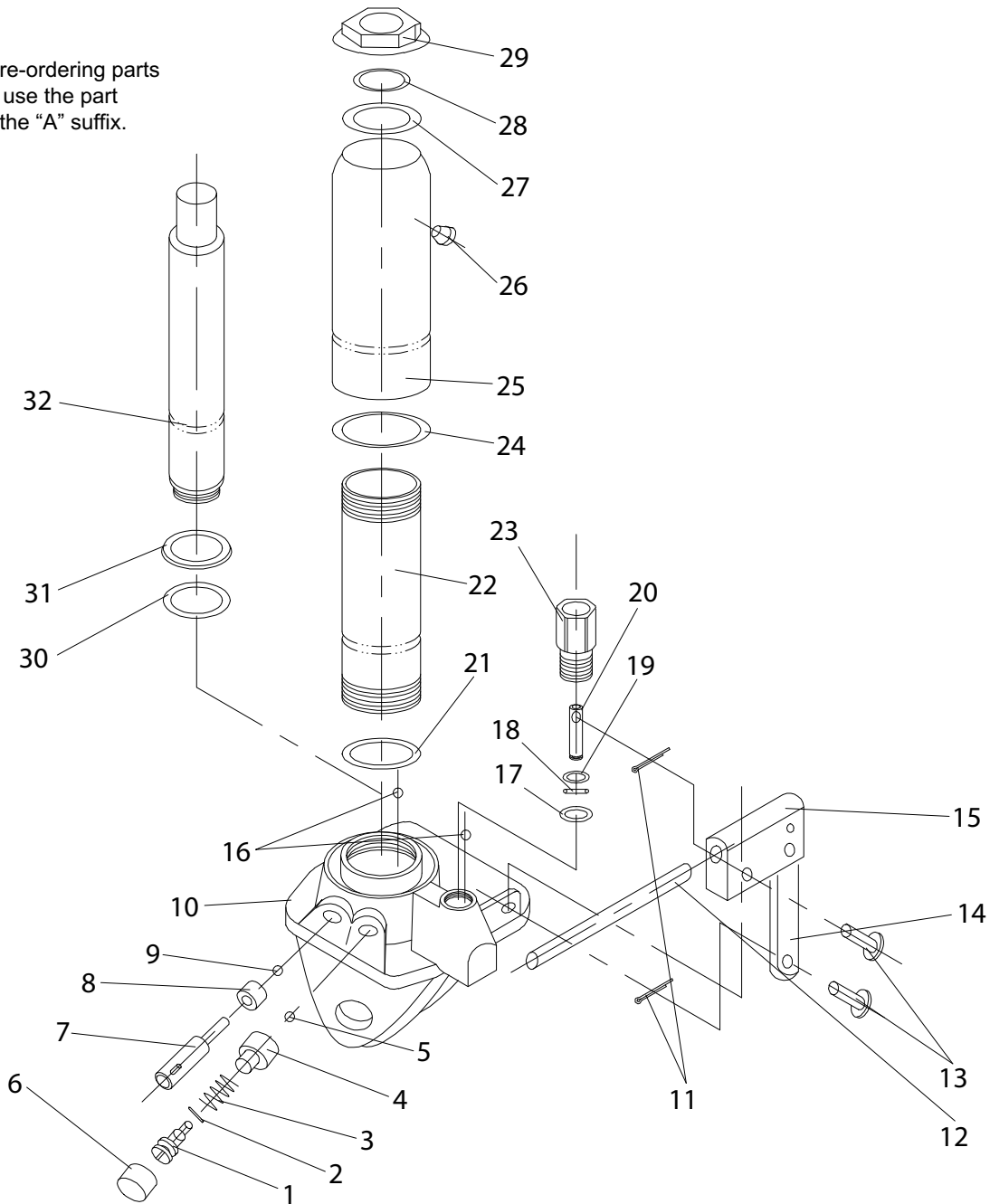

**Record Product's Serial Number Here:** \_\_\_\_\_

**Note:** If product has no serial number, record month and year of purchase instead.

**Note:** Some parts are listed and shown for illustration purposes only, and are not available individually as replacement parts. Specify UPC 193175446725 when ordering parts.

## Limited 90 Day Warranty

Harbor Freight Tools Co. makes every effort to assure that its products meet high quality and durability standards, and warrants to the original purchaser that this product is free from defects in materials and workmanship for the period of 90 days from the date of purchase. This warranty does not apply to damage due directly or indirectly, to misuse, abuse, negligence or accidents, repairs or alterations outside our facilities, criminal activity, improper installation, normal wear and tear, or to lack of maintenance. We shall in no event be liable for death, injuries to persons or property, or for incidental, contingent, special or consequential damages arising from the use of our product. Some states do not allow the exclusion or limitation of incidental or consequential damages, so the above limitation of exclusion may not apply to you. THIS WARRANTY IS EXPRESSLY IN LIEU OF ALL OTHER WARRANTIES, EXPRESS OR IMPLIED, INCLUDING THE WARRANTIES OF MERCHANTABILITY AND FITNESS.

To take advantage of this warranty, the product or part must be returned to us with transportation charges prepaid. Proof of purchase date and an explanation of the complaint must accompany the merchandise. If our inspection verifies the defect, we will either repair or replace the product at our election or we may elect to refund the purchase price if we cannot readily and quickly provide you with a replacement. We will return repaired products at our expense, but if we determine there is no defect, or that the defect resulted from causes not within the scope of our warranty, then you must bear the cost of returning the product.

This warranty gives you specific legal rights and you may also have other rights which vary from state to state.

# ***PITTSBURGH***<sup>™</sup>