

Owner's Manual & Safety Instructions

Save This Manual Keep this manual for the safety warnings and precautions, assembly, operating, inspection, maintenance and cleaning procedures. Write the product's serial number in the back of the manual near the assembly diagram (or month and year of purchase if product has no number). Keep this manual and the receipt in a safe and dry place for future reference.

221

PITTSBURGH®

12V 2-TRUMPET CAR HORN



58808

Visit our website at: <http://www.harborfreight.com>
Email our technical support at: productsupport@harborfreight.com

When unpacking, make sure that the product is intact and undamaged. If any parts are missing or broken, please call 1-888-866-5797 as soon as possible.

Copyright© 2022 by Harbor Freight Tools®. All rights reserved.

No portion of this manual or any artwork contained herein may be reproduced in any shape or form without the express written consent of Harbor Freight Tools. Diagrams within this manual may not be drawn proportionally. Due to continuing improvements, actual product may differ slightly from the product described herein. Tools required for assembly and service may not be included.

⚠WARNING

**Read this material before using this product.
Failure to do so can result in serious injury.
SAVE THIS MANUAL.**

Specifications

| | |
|-------------------|-------------|
| Power Requirement | 12 Volts DC |
| Volume | 118 dB |

IMPORTANT SAFETY INFORMATION

1. Install a 15 amp fuse (not included) inline on the power supply wire of this item. Using no fuse, or using an incorrect fuse can cause an electrical fire.
2. Install only according to these instructions. Improper installation can create hazards.
3. Wear ANSI-approved safety goggles and heavy-duty work gloves during installation.
4. Do not install while engine is running. Remove ignition keys from vehicle and set parking brake.
5. When drilling holes, beware of any hidden electrical lines or cables. Make sure you don't damage or weaken the structural integrity of the vehicle.
6. Do not use as a replacement for Original Equipment Manufacturer (OEM) horn(s).
7. Do not install this product in a location that will exceed 212°F or get submerged in water. It may stop operating if exposed to any of those conditions.
8. Keep assembly area clean and well lit.
9. Keep bystanders out of the area during installation.
10. Do not expose Horns to rain or wet conditions. Water entering the Horns will increase the risk of electric shock.
11. Do not install when tired or when under the influence of alcohol, drugs or medication.
12. Do not install this product yourself unless you are technically competent to do so. If necessary, have a qualified technician install the Horns.
13. This product is not a toy. Do not allow children to play with or near this item.
14. Use as intended only.
15. Inspect before every use; do not use if parts are loose or damaged.
16. Exposure to noise levels over 85 dB is hazardous to hearing. Everyone close enough to horn to be exposed to more than 85 dB must wear ANSI-approved hearing protection. Do not use Horn in close proximity to people or animals, as the decibel level may cause hearing damage.
17. Check and comply with local standards for noise pollution levels before use.
18. Maintain product labels and nameplates. These carry important safety information. If unreadable or missing, contact Harbor Freight Tools for a replacement.
19. The warnings and precautions discussed in this manual cannot cover all possible conditions and situations that may occur. It must be understood by the operator that common sense and caution are factors which cannot be built into this product, but must be supplied by the operator.

Installation Instructions



Read the **ENTIRE IMPORTANT SAFETY INFORMATION** section at the beginning of this document including all text under subheadings therein before set up or use of this product.

⚠️ WARNING

Risk of serious personal injury. Turn the vehicle off and disconnect battery before installation.

Note: If unsure about any aspect of installation, have the Horns installed by a qualified mechanic.

1. Prior to installation, turn off the ignition, shift transmission into park (for automatic transmissions) or reverse (for manual). Remove ignition keys from vehicle and allow engine to cool. Place wheel chocks on both sides of at least two wheels. Disconnect the vehicle's battery. Make sure the engine and engine compartment are cool before installation.
2. Select a suitable location to mount the Horns. Location must shelter Horns from incoming rain, road water, and mud splash from under the vehicle. Do not mount Horns near hot engine components or where it may come into direct contact with hot surfaces or moving parts.

Note: Holes may need to be drilled in the vehicle chassis to mount the Horns, Air Compressor and 12V Relay. Make sure no electrical wires or cables or any other obstructions or vehicle components are in the way of the drilling path.

3. Mount the Horns, Air Compressor and 12V Relay to the vehicle's chassis using the supplied Mounting Brackets, Nuts and Bolts. Point the Horns forward and slightly down for maximum efficiency.
4. Tighten Nuts to secure the Horns, Air Compressor and 12V Relay to the mounting location.

5. Connect Air Tube to Air Compressor, 3-Way Tube Adapter and then to both Horns.
6. Make connections to the Horns, Air Compressor and 12V Relay as shown on the Wiring Diagram using terminal connectors (not included) on all connections. Pay attention to polarity. For negative ground systems (most vehicles), have a qualified mechanic install the horn.



Install a 15 amp fuse (not included) inline on the power supply wire of this item. Using no fuse, or using an incorrect fuse can cause an electrical fire.

Negative Ground Wiring Diagram

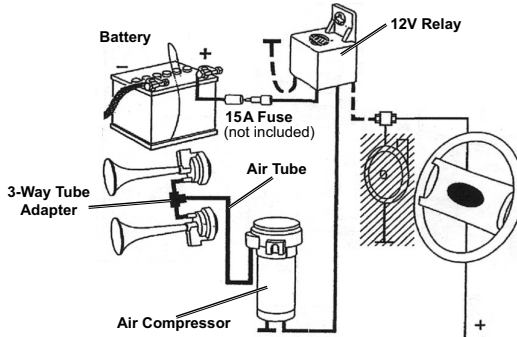

Parts List and Diagram

| Part | Description | Qty |
|------|--------------------|-----|
| 1 | Air Compressor | 1 |
| 2 | High-Tone Air Horn | 1 |
| 3 | Low-Tone Air Horn | 1 |
| 4 | 12V Relay | 1 |
| 5 | Air Tube | 1 |
| 6 | Mounting Bracket | 2 |
| 7 | Nut | 4 |
| 8 | Bolt | 4 |
| 9 | Nut | 1 |
| 10 | Bolt | 1 |
| 11 | 3-Way Tube Adapter | 1 |

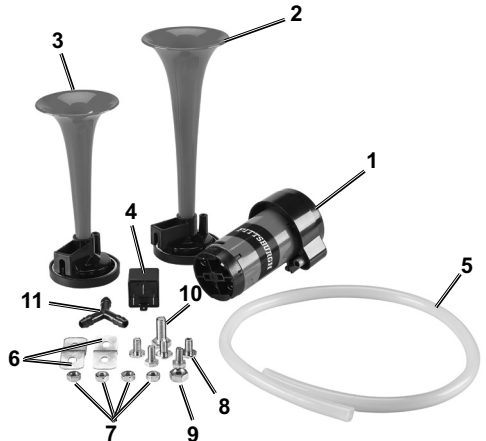

Record Serial Number Here: _____

Note: If product has no serial number, record month and year of purchase instead.

Note: Some parts are listed and shown for illustration purposes only, and are not available individually as replacement parts. Specify UPC 193175446886 when ordering parts.

PLEASE READ THE FOLLOWING CAREFULLY

THE MANUFACTURER AND/OR DISTRIBUTOR HAS PROVIDED THE PARTS LIST AND ASSEMBLY DIAGRAM IN THIS DOCUMENT AS A REFERENCE TOOL ONLY. NEITHER THE MANUFACTURER OR DISTRIBUTOR MAKES ANY REPRESENTATION OR WARRANTY OF ANY KIND TO THE BUYER THAT HE OR SHE IS QUALIFIED TO MAKE ANY REPAIRS TO THE PRODUCT, OR THAT HE OR SHE IS QUALIFIED TO REPLACE ANY PARTS OF THE PRODUCT. IN FACT, THE MANUFACTURER AND/OR DISTRIBUTOR EXPRESSLY STATES THAT ALL REPAIRS AND PARTS REPLACEMENTS SHOULD BE UNDERTAKEN BY CERTIFIED AND LICENSED TECHNICIANS, AND NOT BY THE BUYER. THE BUYER ASSUMES ALL RISK AND LIABILITY ARISING OUT OF HIS OR HER REPAIRS TO THE ORIGINAL PRODUCT OR REPLACEMENT PARTS THERETO, OR ARISING OUT OF HIS OR HER INSTALLATION OF REPLACEMENT PARTS THERETO.

Limited 90 Day Warranty

Harbor Freight Tools Co. makes every effort to assure that its products meet high quality and durability standards, and warrants to the original purchaser that this product is free from defects in materials and workmanship for the period of 90 days from the date of purchase. This warranty does not apply to damage due directly or indirectly, to misuse, abuse, negligence or accidents, repairs or alterations outside our facilities, criminal activity, improper installation, normal wear and tear, or to lack of maintenance. We shall in no event be liable for death, injuries to persons or property, or for incidental, contingent, special or consequential damages arising from the use of our product. Some states do not allow the exclusion or limitation of incidental or consequential damages, so the above limitation of exclusion may not apply to you. THIS WARRANTY IS EXPRESSLY IN LIEU OF ALL OTHER WARRANTIES, EXPRESS OR IMPLIED, INCLUDING THE WARRANTIES OF MERCHANTABILITY AND FITNESS.

To take advantage of this warranty, the product or part must be returned to us with transportation charges prepaid. Proof of purchase date and an explanation of the complaint must accompany the merchandise. If our inspection verifies the defect, we will either repair or replace the product at our election or we may elect to refund the purchase price if we cannot readily and quickly provide you with a replacement. We will return repaired products at our expense, but if we determine there is no defect, or that the defect resulted from causes not within the scope of our warranty, then you must bear the cost of returning the product.

This warranty gives you specific legal rights and you may also have other rights which vary from state to state.

PITTSBURGH[®]