

### IMPORTANT SAFETY INSTRUCTIONS

**DANGER - RISK OF SHOCK - DISCONNECT POWER BEFORE INSTALLATION.**

The retrofit kits including LED tube, instruction, field-applied label.



Please confirm Lamp to Lamp spacing minimum 15cm before installing

THIS PRODUCT MUST BE INSTALLED IN ACCORDANCE WITH THE APPLICABLE INSTALLATION CODE BY A PERSON FAMILIAR WITH THE CONSTRUCTION AND OPERATION OF THE PRODUCT AND THE HAZARDS INVOLVED.

1. **WARNING** - Risk of fire or electric shock. LED Retrofit Kit Installation requires knowledge of luminaires electrical systems. If not qualified, do not attempt installation. Contact a qualified electrician.
2. Install this kit only in the luminaires that have the construction features and dimensions shown in the photographs and/or drawings.
3. Do not make or alter any open holes in an enclosure of wiring or electrical components during installation.
4. To prevent wiring damage or abrasion, do not expose wiring to edges of sheet metal or other sharp objects.

- To avoid potential fire or shock hazard, do not use in luminaires employing shunted bi-pin lampholders. NOTE: Shunted lamp holders are found only in fluorescent luminaires with Instant Start ballasts. Instant Start ballasts can be indentified by the words “Instant Start” or “I.S.” marked on the ballast. This designation may be in the form of a statement pertaining to the ballast itself, or may be combined with the marking for the lamps with which the ballast is intended to be used, for example F40T12/IS. For more information, contact the LED luminaire retrofit kit manufacturer.
- Installers should not disconnect existing wires from lampholder terminals to make new connections at lampholder terminals. Instead, installers should cut existing lampholder leads away from the lampholder and make new electrical connections to lampholder lead wires by employing applicable connectors.
- Not for use with dimmers.
- These products are not suitable for use with emergency exit fixtures or emergency exit lights.

**Save all warnings and instructions for future reference.**

## Installation

### One LED T8 Tube Installation

- Shut off power before work.
- Disconnect luminaire supply wirings L (Line) and N (Neutral) to branch circuit as shown.

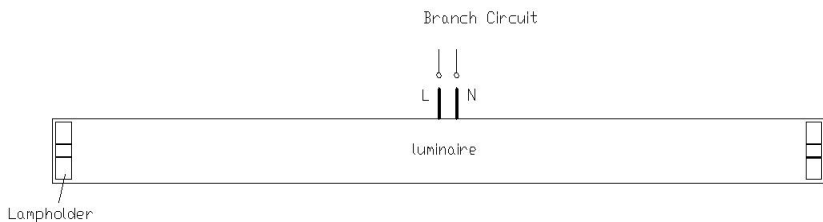

3. Install the LED T8 tube on the luminaire bracket.

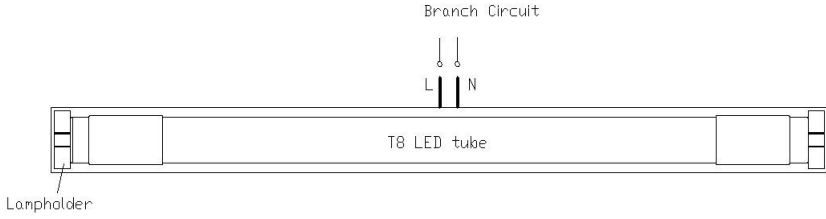

4. Turn on the AC power source, LED Tube will light.

### Installation of Multiple LED T8 Tubes

Repeat Steps 1 - 4

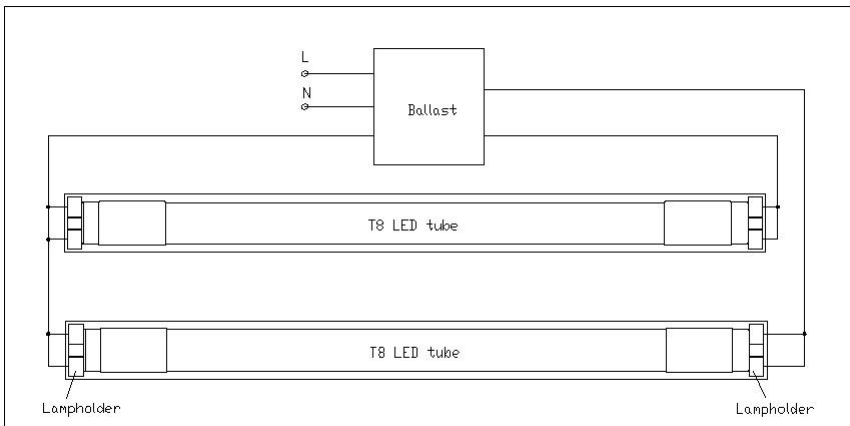

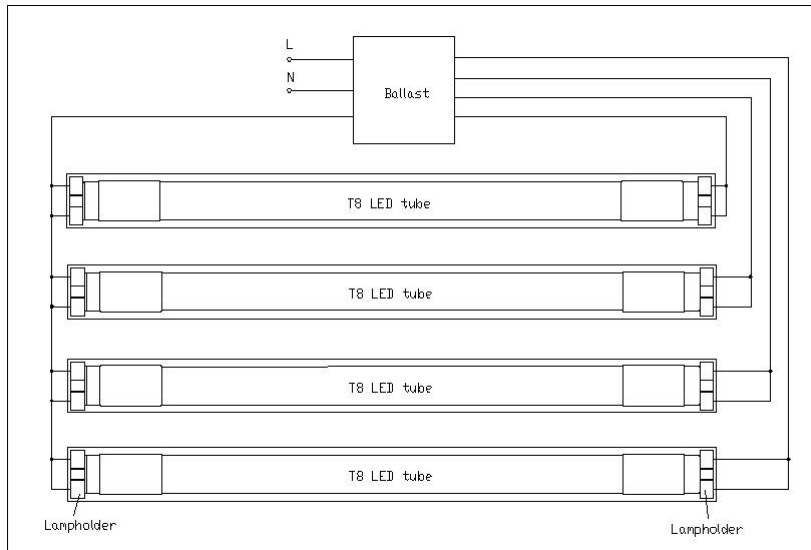
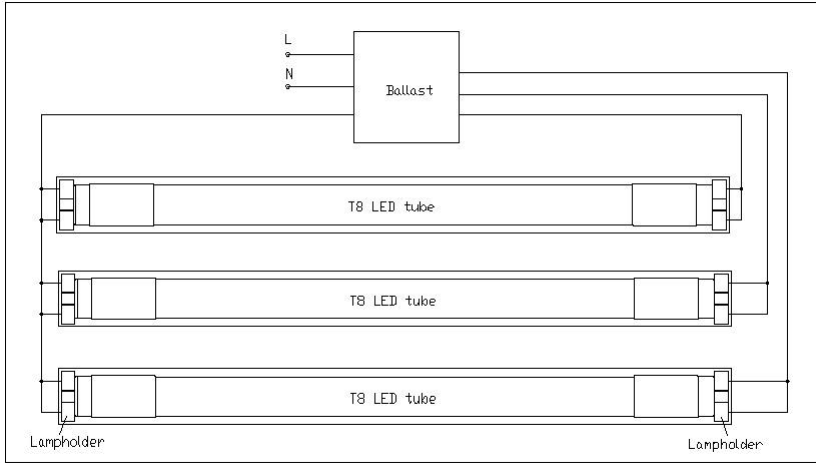

Visit our website at: <http://www.harborfreight.com>  
Email our technical support at: [productsupport@harborfreight.com](mailto:productsupport@harborfreight.com)  
For technical questions, please call 1-888-866-5797.