

Owner's Manual & Safety Instructions

Save This Manual Keep this manual for the safety warnings and precautions, assembly, operating, inspection, maintenance and cleaning procedures. Write the product's serial number in the back of the manual (or month and year of purchase if product has no number). Keep this manual and the receipt in a safe and dry place for future reference.

221



60" 3 DRAWER WOOD WORKBENCH



Visit our website at: <http://www.harborfreight.com>
Email our technical support at: productsupport@harborfreight.com

58832

When unpacking, make sure that the product is intact and undamaged. If any parts are missing or broken, please call 1-888-866-5797 as soon as possible.

Copyright© 2021 by Harbor Freight Tools®. All rights reserved.
No portion of this manual or any artwork contained herein may be reproduced in any shape or form without the express written consent of Harbor Freight Tools. Diagrams within this manual may not be drawn proportionally. Due to continuing improvements, actual product may differ slightly from the product described herein.
Tools required for assembly and service may not be included.

⚠ WARNING

**Read this material before using this product.
Failure to do so can result in serious injury.
SAVE THIS MANUAL.**

Table of Contents

Important Safety Information	3	Parts List and Diagram	10
Specifications	4	Warranty	12
Assembly Instructions	5		

SAFETY



SETUP

OPERATION

MAINTENANCE

WARNING SYMBOLS AND DEFINITIONS	
	This is the safety alert symbol. It is used to alert you to potential personal injury hazards. Obey all safety messages that follow this symbol to avoid possible injury or death.
! DANGER	Indicates a hazardous situation which, if not avoided, will result in death or serious injury.
! WARNING	Indicates a hazardous situation which, if not avoided, could result in death or serious injury.
! CAUTION	Indicates a hazardous situation which, if not avoided, could result in minor or moderate injury.
NOTICE CAUTION	Addresses practices not related to personal injury.

IMPORTANT SAFETY INFORMATION

WARNING

Read all safety warnings and instructions.

Failure to follow the warnings and instructions may result in serious injury.

Save all warnings and instructions for future reference.

1. **Do not exceed weight capacity for the Workbench. Be aware of dynamic loading!**
Sudden load movement may briefly create excess load causing product failure.
2. Use only on flat, level and hard surface capable of supporting the Workbench and any item(s) placed on Workbench. Evenly distribute load on Table to avoid tipping.
3. Use as intended only. Do not use Workbench to perform task for which it was not designed.
4. For indoor use only.
5. Assemble only according to these instructions. Improper assembly can create hazards.
6. Wear ANSI-approved safety goggles and heavy-duty work gloves during assembly and use.
7. Keep assembly area clean and well lit.
8. Keep bystanders out of the area during assembly.
9. Do not assemble when tired or when under the influence of drugs or medication.
10. This product is not a toy. Do not allow children to play with, on or near Workbench.
11. Inspect before every use; do not use if parts are loose or damaged.
12. Maintain product labels and nameplates. These carry important safety information. If unreadable or missing, contact Harbor Freight Tools for a replacement.



SAVE THESE INSTRUCTIONS.



Specifications

Total Combined Weight Capacity	600 lb.
Vise Capacity	7-1/4"
Table Top Thickness	2-1/2"

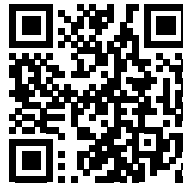

Assembly Video
Scan code using your phone.
<https://hf.tools/yukon3drawer/>



SAFETY

SETUP

OPERATION

MAINTENANCE

Assembly Instructions



Read the **ENTIRE IMPORTANT SAFETY INFORMATION** section at the beginning of this manual including all text under subheadings therein before set up or use of this product.

Note: For additional information regarding the parts listed in the following pages, refer to *Parts List and Diagram* on page 10.

Note: More than one person is needed for proper assembly.

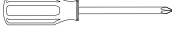
Note: Additional tool for assembly not included. 

1. Insert Connecting Nuts (17) into holes at ends of a Cross Brace (5). Make sure that the slots on the Nuts align horizontally. This will allow the Bolts to be threaded into the Cross Brace in the next step.
4. Once both Legs have been fastened to the Cross Brace, slide the Bottom Shelf (6) between the Legs so that the far edge fits onto the groove on the Cross Brace.

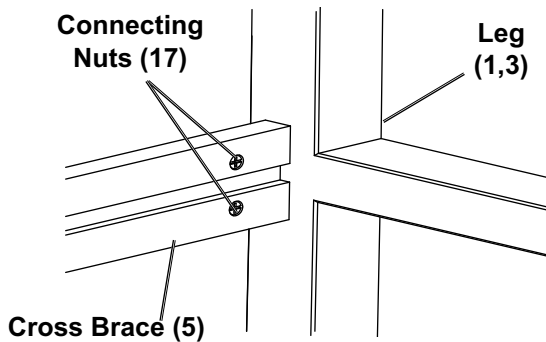

2. Set the Cross Brace against a Leg (1) and use the Hex Key (18) and 6 x 90mm Connecting Bolts (16) to fasten the Cross Brace and Leg together.

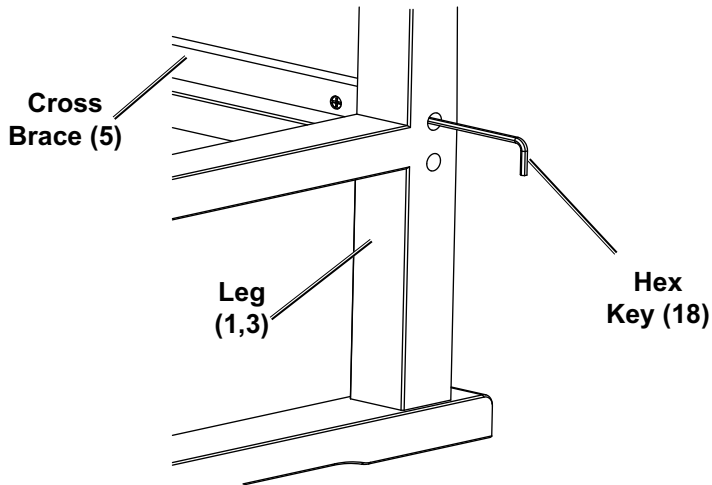

NOTE: Make sure the groove in the Cross Brace is facing IN.

3. Repeat step 2 for the second Leg (3).

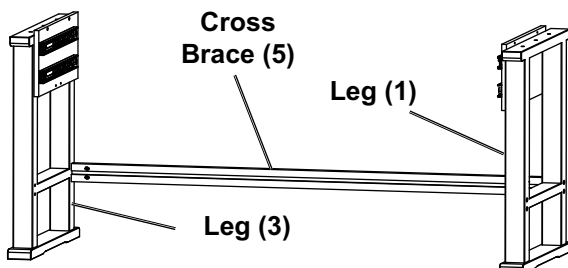

5. Set the second Cross Brace against the other edge of the Bottom Shelf.

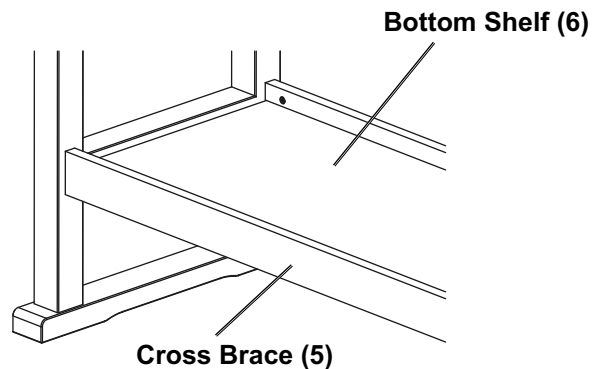
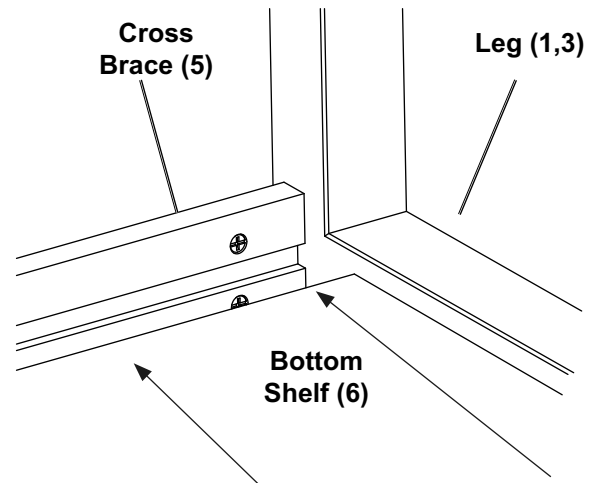

6. Once the Cross Brace is in place and the mounting holes on the Legs are aligned with the Connecting Nuts in the Cross Brace, use the Hex Key and Connecting Bolts to fasten the second Cross Brace to both Legs.

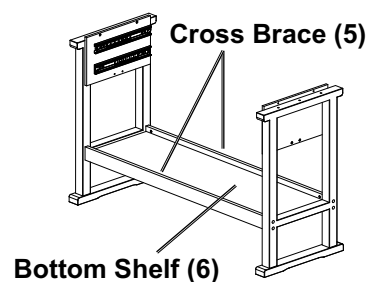

- With assistance, place the Table Top (2) face down on a smooth, padded surface. This will allow installation of the sliding drawers.
- Set the Sliding Partition (8) into place by inserting the tabs at the end of the Partition into the holes at the center of the Table Top's underside.

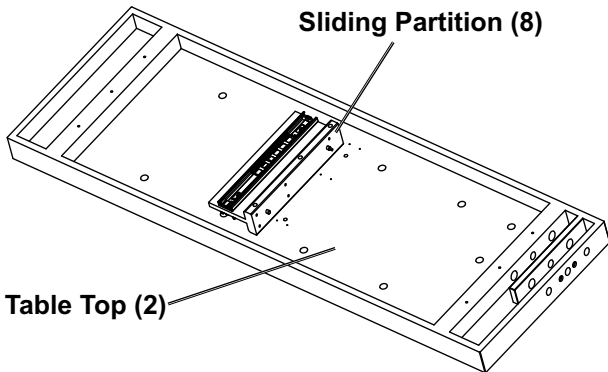

Note: Verify that the Sliding Partition and Table Top face the same direction.

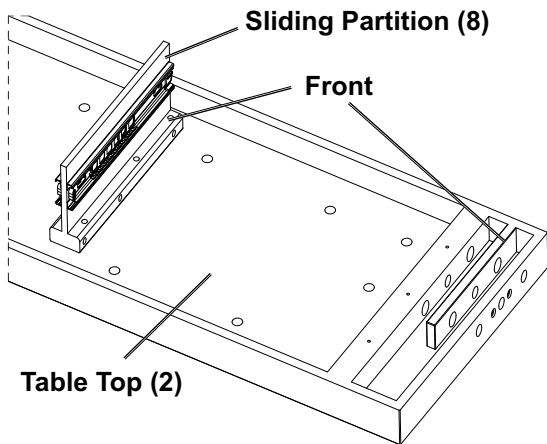

- Use 4 x 30mm Wood Screws (24) to fasten the Sliding Partition to the middle of the Table Top's underside.

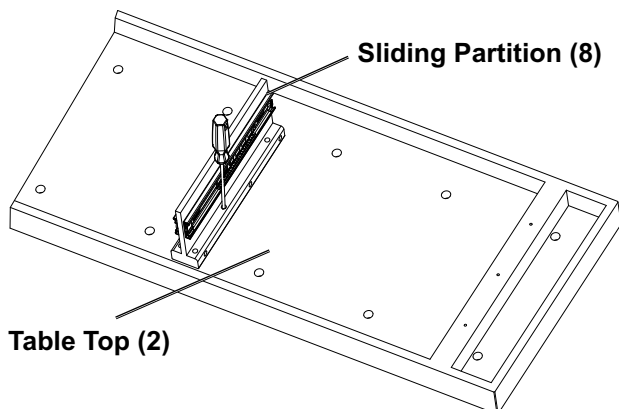

- With assistance, set the assembled Legs and Bottom Shelf onto the underside of the Table Top.

Note: When setting the assembled Legs onto the Table Top, verify both Legs and Table Top are facing the correct direction.

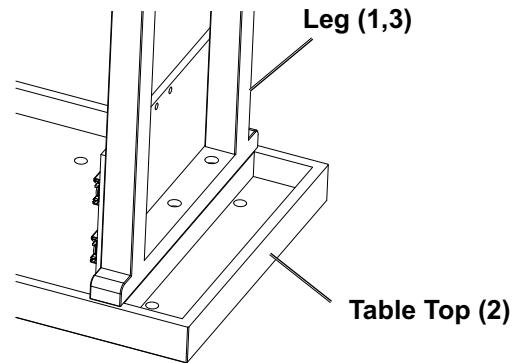

Note: Verify that the Drawer guide slots on the Sliding Partition face the same way as the Drawer guide slots on the Legs.

- Use the Hex Key and 6 x 50mm Wood Screws (15) to fasten the Legs to the Table Top underside, using three Screws per side.

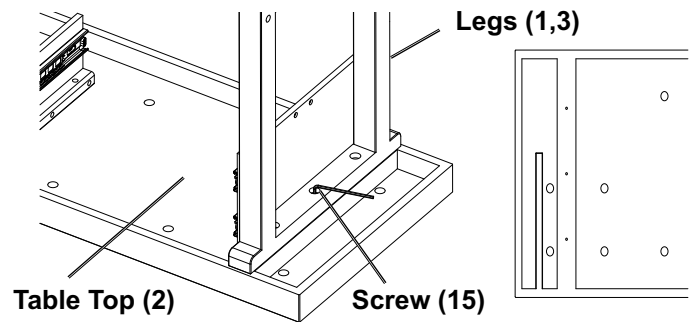

- Fasten Sliding Partition to the Table Top frame using four 4 x 25 Wood Screws (22).

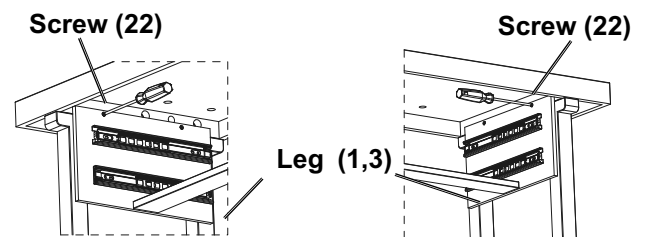

13. Attach the Middle Cross Brace (7) on the Sliding Partition (8) and fasten it to the Legs (1,3) using Wood Screws (22).

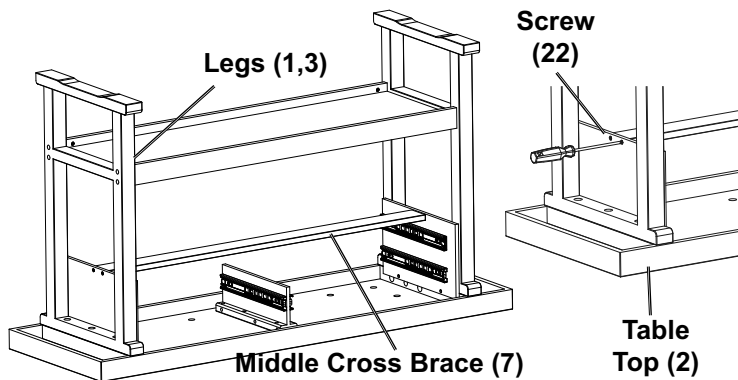

18. Fasten a Left Drawer Slot Panel (11) and a Right Drawer Slot Panel (12) to a Drawer Front Panel (9).

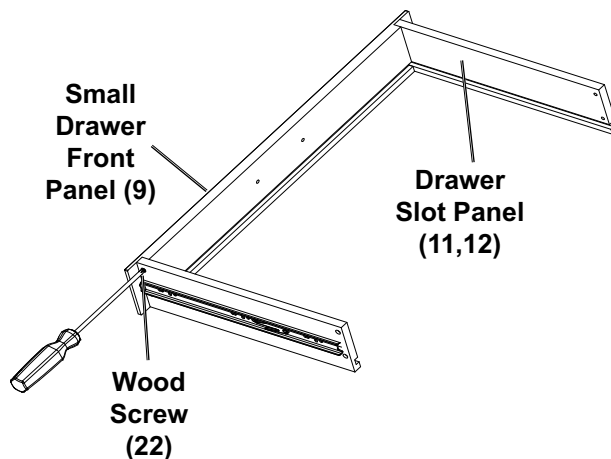

14. With assistance, set the assembled frame right-side up where desired.

15. Remove the Vise Screw/Washer (21) from the middle threaded rod of the Vise (4).

Vise (4)

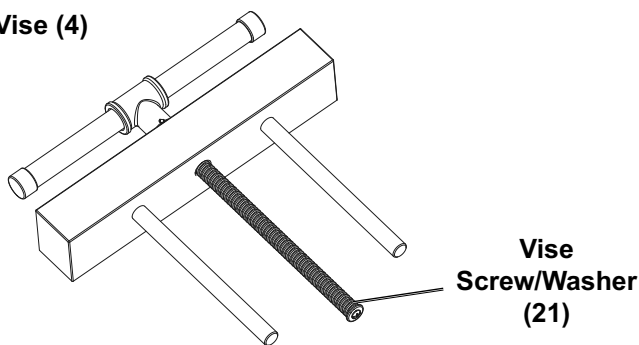

19. With the felt side up, slide a Drawer Bottom (13) into the grooves along the insides of the assembled Left and Right Drawer Slot Panels from the previous step. Fasten a Drawer Back Panel (10) to the ends of the two Slot Panels, then fasten Drawer Bottom to Drawer Back Panel.

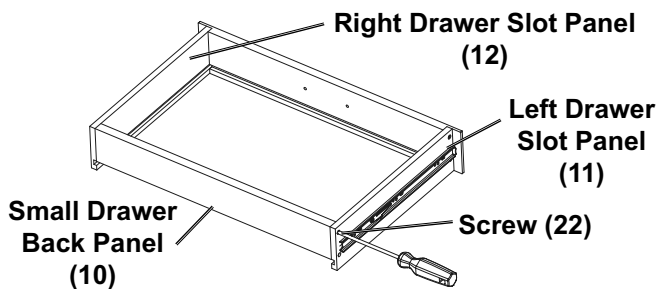

Note: Install Vise with slots facing up.

16. With the Vise Screw/Washer removed, slide the Vise into the three holes on the side of the Workbench.

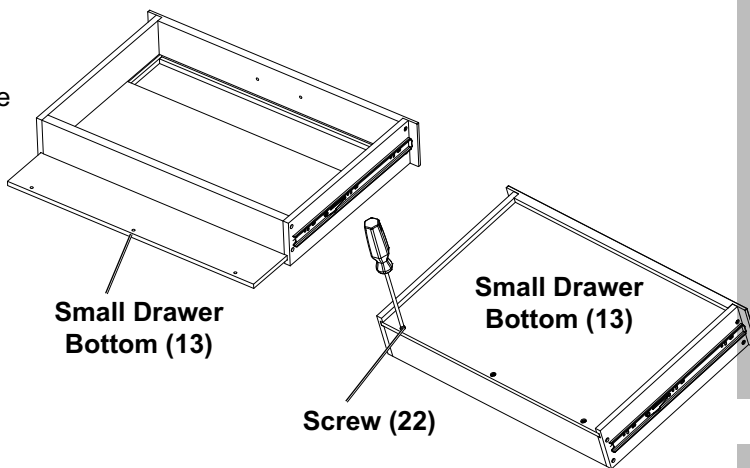
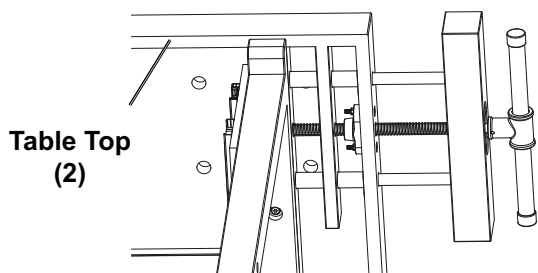

17. Use the Vise handle to thread the Vise in all the way and re-install the Vise Screw/Washer. This will keep the Vise locked in place on the side of the Workbench.

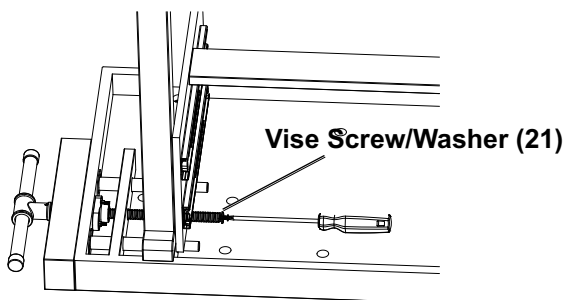

Note: Use the 4 x 25mm Wood Screws (22) to fasten the Drawer Bottom (25) to the Drawer Front Panels (27). This only applies to the Large Drawer.

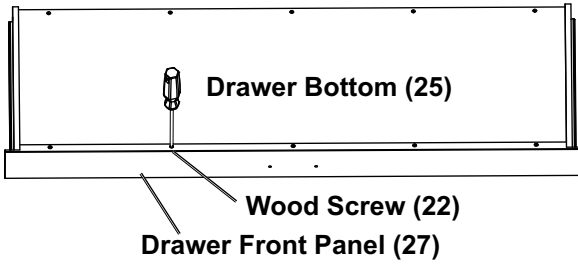

20. Use the Bolts (23) to fasten the Drawer Handles (14) to the Drawer Front Panels (9).

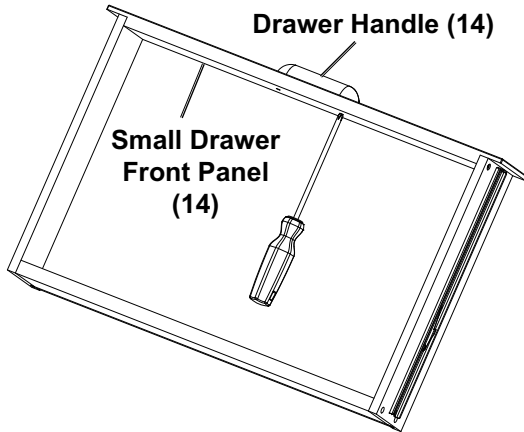

Note: Each Drawer piece should have a sticker designating what it is. Use the Parts List as a reference to help ensure correct assembly.

21. Repeat Steps 18,19 and 20 for other drawers.

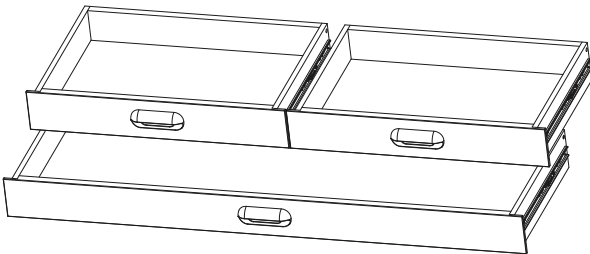

22. Once the Drawer is fully assembled, verify that the inside tracks along the legs and Sliding Partition are pushed forward.

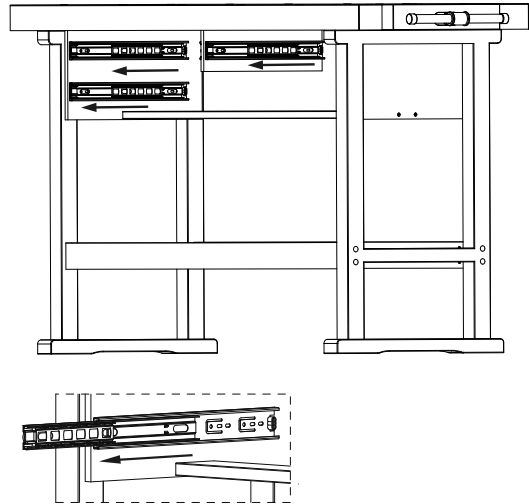

23. Insert the drawer horizontally along the inside tracks, sliding the drawer back and forth until the drawer is completely pushed in.

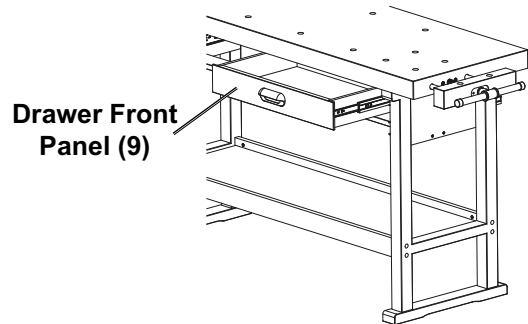

24. Once all Drawers are inserted, tap Wood Pegs (19) and Anvil Pegs (20) into desired holes on the Table Top.

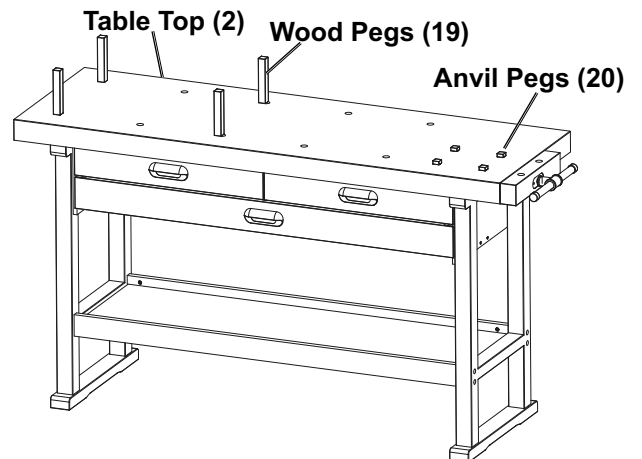

The Workbench is now fully assembled and ready for use.

Operation Instructions

1. Place Anvil Pegs (20) into Vise (4) slots and Table Top (2) slots too firmly hold work piece into position. Anvil Pegs can be used with Wood Pegs (19).
2. Place Wood Pegs into Vise slots and Table Top slots to firmly hold work piece into position. Wood Pegs can be used with Anvil Pegs.

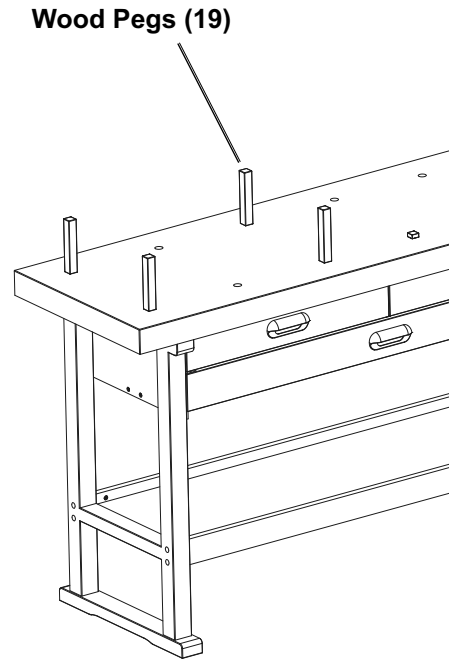
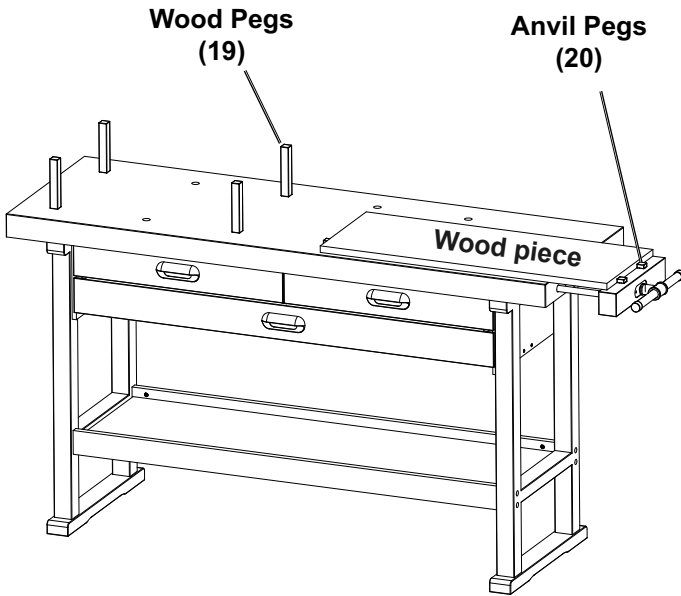

Maintenance and Servicing



Procedures not specifically explained in this manual must be performed only by a qualified technician.

WARNING

TO PREVENT SERIOUS INJURY FROM ACCIDENTAL OPERATION:

Turn the Power Switch of the tool off and unplug the tool from its electrical outlet before performing any inspection, maintenance, or cleaning procedures.

TO PREVENT SERIOUS INJURY FROM TOOL FAILURE:

Do not use damaged equipment. If abnormal noise or vibration occurs, have the problem corrected before further use.

Cleaning, Maintenance, and Lubrication

1. **BEFORE EACH USE**, inspect the general condition of the Workbench. Check for:
 - loose hardware
 - misalignment or binding of parts
 - cracked or broken parts
 - any other condition that may affect its safe operation.
2. **AFTER USE**, wipe external surfaces of the Workbench with clean cloth.

PLEASE READ THE FOLLOWING CAREFULLY

THE MANUFACTURER AND/OR DISTRIBUTOR HAS PROVIDED THE PARTS LIST AND ASSEMBLY DIAGRAM IN THIS MANUAL AS A REFERENCE TOOL ONLY. NEITHER THE MANUFACTURER OR DISTRIBUTOR MAKES ANY REPRESENTATION OR WARRANTY OF ANY KIND TO THE BUYER THAT HE OR SHE IS QUALIFIED TO MAKE ANY REPAIRS TO THE PRODUCT, OR THAT HE OR SHE IS QUALIFIED TO REPLACE ANY PARTS OF THE PRODUCT. IN FACT, THE MANUFACTURER AND/OR DISTRIBUTOR EXPRESSLY STATES THAT ALL REPAIRS AND PARTS REPLACEMENTS SHOULD BE UNDERTAKEN BY CERTIFIED AND LICENSED TECHNICIANS, AND NOT BY THE BUYER. THE BUYER ASSUMES ALL RISK AND LIABILITY ARISING OUT OF HIS OR HER REPAIRS TO THE ORIGINAL PRODUCT OR REPLACEMENT PARTS THERETO, OR ARISING OUT OF HIS OR HER INSTALLATION OF REPLACEMENT PARTS THERETO.

Parts List

Part	Description	Qty
1	Left Leg	1
2	Table Top	1
3	Right Leg	1
4	Vise	1
5	Cross Brace	2
6	Bottom Shelf	1
7	Middle Cross Brace	1
8	Sliding Partition	1
9	Drawer Front Panel	3
10	Drawer Back Panel	3
11	Left Drawer Slot Panel	3
12	Right Drawer Slot Panel	3
13	Small Drawer Bottom	2
14	Drawer Handle	3

Part	Description	Qty
15	6 x 50mm Wood Screw	6
16	6 x 90mm Connecting Bolt	8
17	Connecting Nut	8
18	Hex Key	1
19	Wood Peg	4
20	Anvil Peg	4
21	Vise Screw/Washer	1
22	4 x 25mm Wood Screw	62
23	4 x 30mm Drawer Bolt	6
24	4 x 30mm Wood Screw	6
25	Large Drawer Bottom	1
26	Large Drawer Back Panel	1
27	Large Drawer Front Panel	1

Note: A few pieces of extra hardware may be included.

Assembly Diagram

SAFETY

SETUP

OPERATION

MAINTENANCE

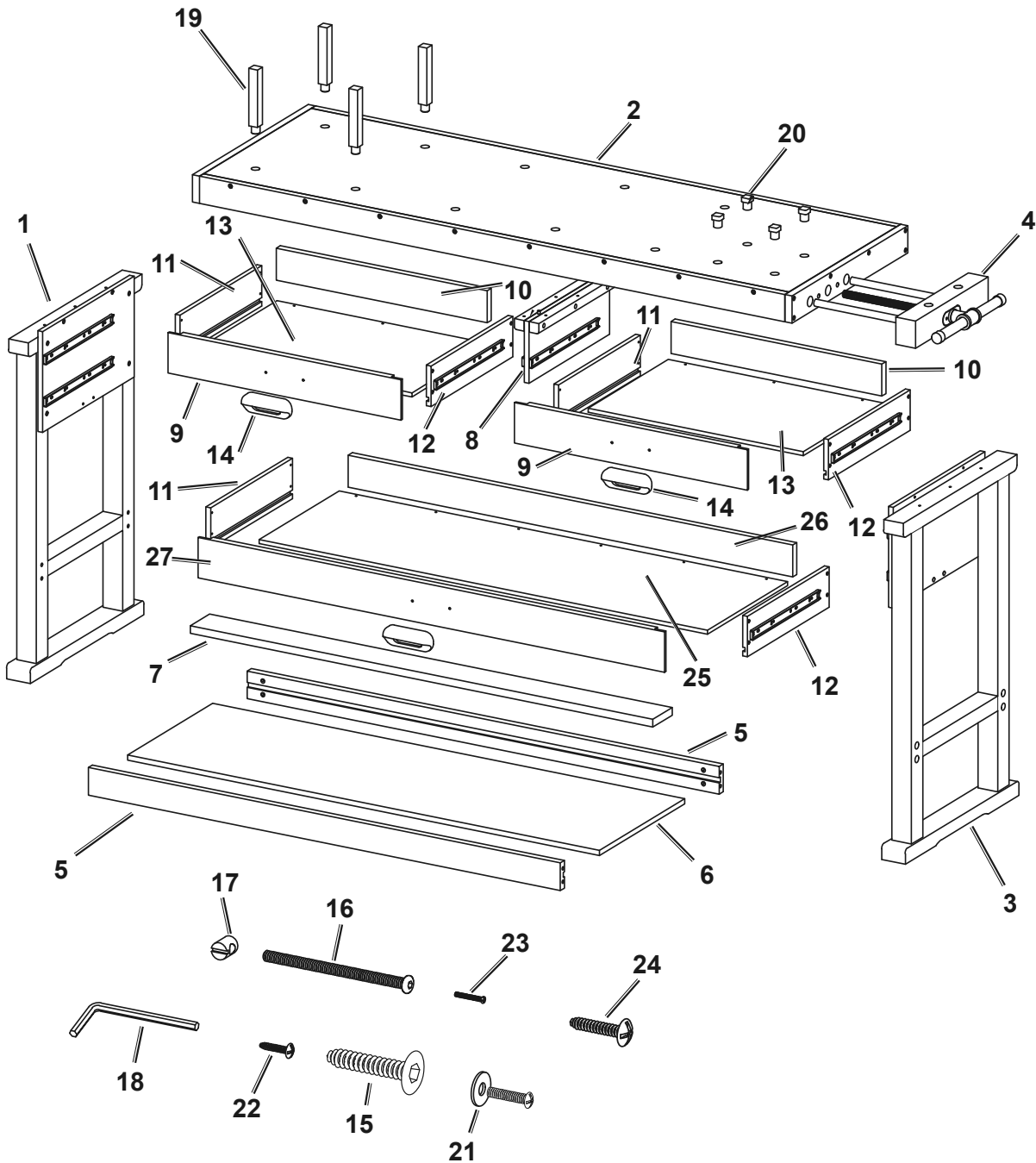

Record Product's Serial Number Here: _____

Note: If product has no serial number, record month and year of purchase instead.

Note: Some parts are listed and shown for illustration purposes only, and are not available individually as replacement parts. Specify UPC 193175447586 when ordering parts.

Limited 90 Day Warranty

Harbor Freight Tools Co. makes every effort to assure that its products meet high quality and durability standards, and warrants to the original purchaser that this product is free from defects in materials and workmanship for the period of 90 days from the date of purchase. This warranty does not apply to damage due directly or indirectly, to misuse, abuse, negligence or accidents, repairs or alterations outside our facilities, criminal activity, improper installation, normal wear and tear, or to lack of maintenance. We shall in no event be liable for death, injuries to persons or property, or for incidental, contingent, special or consequential damages arising from the use of our product. Some states do not allow the exclusion or limitation of incidental or consequential damages, so the above limitation of exclusion may not apply to you. THIS WARRANTY IS EXPRESSLY IN LIEU OF ALL OTHER WARRANTIES, EXPRESS OR IMPLIED, INCLUDING THE WARRANTIES OF MERCHANTABILITY AND FITNESS.

To take advantage of this warranty, the product or part must be returned to us with transportation charges prepaid. Proof of purchase date and an explanation of the complaint must accompany the merchandise. If our inspection verifies the defect, we will either repair or replace the product at our election or we may elect to refund the purchase price if we cannot readily and quickly provide you with a replacement. We will return repaired products at our expense, but if we determine there is no defect, or that the defect resulted from causes not within the scope of our warranty, then you must bear the cost of returning the product.

This warranty gives you specific legal rights and you may also have other rights which vary from state to state.



26677 Agoura Road • Calabasas, CA 91302 • 1-888-866-5797