

Owner's Manual & Safety Instructions

Save This Manual Keep this manual for the safety warnings and precautions, assembly, operating, inspection, maintenance and cleaning procedures. Write the product's serial number in the back of the manual near the assembly diagram (or month and year of purchase if product has no number). Keep this manual and the receipt in a safe and dry place for future reference.

24b

PITTSBURGH®

MINI-TIRE CHANGER

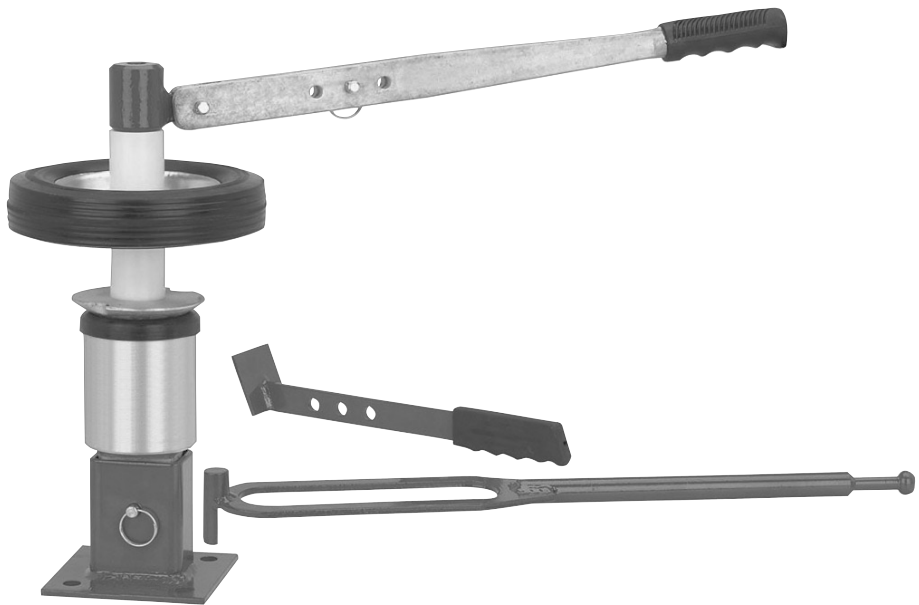

Visit our website at: <http://www.harborfreight.com>
Email our technical support at: productsupport@harborfreight.com

When unpacking, make sure that the product is intact and undamaged. If any parts are missing or broken, please call 1-888-866-5797 as soon as possible.

Copyright© 2023 by Harbor Freight Tools®. All rights reserved.
No portion of this manual or any artwork contained herein may be reproduced in any shape or form without the express written consent of Harbor Freight Tools. Diagrams within this manual may not be drawn proportionally. Due to continuing improvements, actual product may differ slightly from the product described herein. Tools required for assembly and service may not be included.

⚠WARNING

Read this material before using this product.
Failure to do so can result in serious injury.
SAVE THIS MANUAL.

Specifications

Tire Rim Capacity	4" to 10" Rim
Height	16"
Includes	(2) Bead Breaker Handles 21" Long Mounting/Demounting Tool Aluminum Centering Cone (2) Nylon Spacers

Important Safety Information

1. Do not exceed max. tire capacity. Do not use on tires with rims exceeding 10" diameter.
2. Wear ANSI-approved safety goggles and heavy-duty work gloves during assembly, mounting and use.
3. Use as intended only. This Mini-Tire Changer has been designed for ATV's, and golf carts. Use only with vehicle tires for which it was designed.
4. Do not modify Mini-Tire Changer to perform tasks for which it was not designed.
5. Use only with accessories included with the Mini-Tire Changer.
6. Mount only to a secure, level surface able to support weight of Mini-Tire Changer and tire assembly.
7. Verify that mounting surface has no hidden utility lines before drilling or driving screws.
8. Lubricate Breaker Handles when removing tire from rim; failure to do so can lead to property damage.
9. Keep work area clean and well lit.
10. Keep bystanders out of the area during use.
11. Do not use when tired or when under the influence of drugs, medication or alcohol.
12. This product is not a toy. Do not allow children to play with or near this item.
13. Inspect before every use; do not use if parts are loose or damaged.
14. Maintain product labels and nameplates. These carry important safety information. If unreadable or missing, contact Harbor Freight Tools for a replacement.

PITTSBURGH[®]

Mounting Instructions



Read the **ENTIRE IMPORTANT SAFETY INFORMATION** section at the beginning of this document including all text under subheadings therein before set up or use of this product.

1. The Mini Tire-Changer can be mounted temporarily in a vise (not included) or permanently to a secure workbench or surface.
2. For permanent mounting, use pencil to mark installation holes. Use mounting hardware (not included) to mount the Base onto a secure workbench or stand, making sure that there are no hidden cables or wiring below installation surface.
3. Verify that all hardware (use 7/16" or 1/2" bolts, flat and lock washers and nuts) is secure and that base is mounted evenly and is level.
4. Insert Holder (11) into Base and lock together using the Base Pin (9). See Figure A.
5. For temporary mounting to a vise, position the Base between vise jaws with the Base Pin accessible from the sides of the vise. Tighten vise jaws, Use vise jaw guards to prevent damage to Holder surfaces. See Figure B.

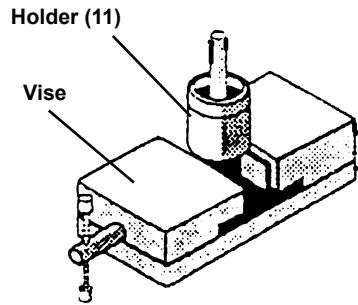

Figure B

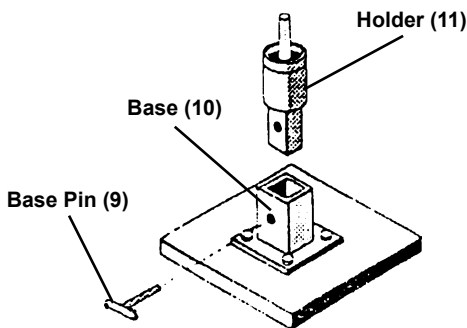

Figure A

PITTSBURGH®

Operation Instructions



Read the **ENTIRE IMPORTANT SAFETY INFORMATION** section at the beginning of this document including all text under subheadings therein before set up or use of this product.

Removing Tire

CAUTION! TO PREVENT INJURY:

Sharp edges can be left on the rim. Wear heavy-duty work gloves and use caution when handling.

NOTICE: To prevent property damage, failure to use tire mounting lubricant when removing the tire from the rim may result in damage to the bead.

1. Remove balancing weights, if any, from rim edges.
2. Remove tire valve core to deplete the tire.
3. Place tire rim over Threaded Shaft (13). See Figure C.

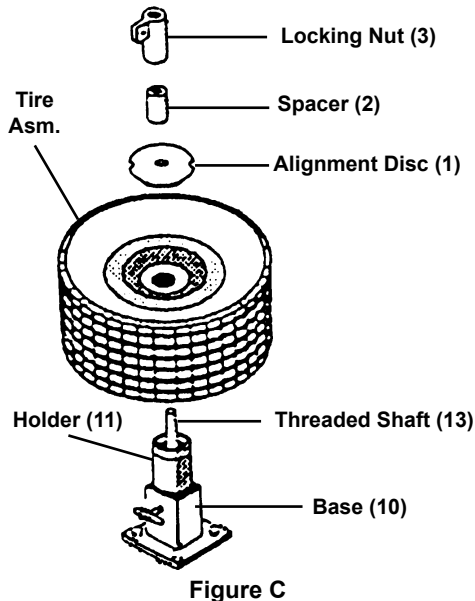

4. Install cone end of the Alignment Disc (1) over the Threaded Shaft.
5. Place both Spacers (2) over the shaft.
6. Thread the Locking Nut (3) over the Threaded Shaft and tighten.
7. Attach the end of the Forcing Handle (5) to the tab of the Locking Nut using one of the Pins (6).
8. Insert Breaker Handle (4) through the slot in Forcing Handle and attach the rubberized Grip (8) to the Breaker Handle, making sure that the finger grip end of the handle is towards the Locking Nut.
9. To break tire beads, Breaker Handle foot should rest horizontally over the tire at edge of rim. (Use combination of adjustment holes in the Forcing Handle and Breaker Handle and if required, remove one of the Spacers). See Figure D.

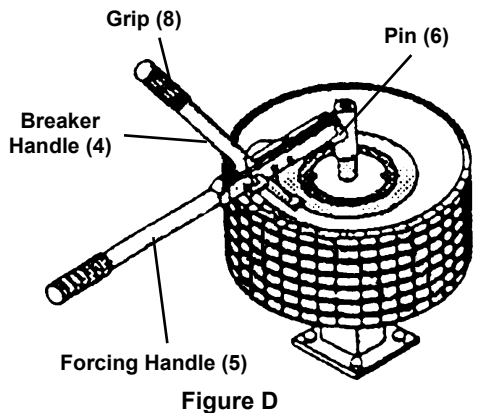

10. Pull down on both handles until the bead slides off the rim.
11. Remove mounting components and flip the tire up, forcing it off the rim.
12. Remove Pin and Forcing Handle from the Locking Nut.
13. Lubricate each bead with tire mounting lubricant (sold separately) to facilitate sliding of the bead over the rim and reduce the risk of tire damage.
14. Push down on tire until there is enough room to place the ball end of the Mounting/Demounting Tool (7) under the bead on the opposite end of the tire. See Figure E.

Mounting/Demounting Tool

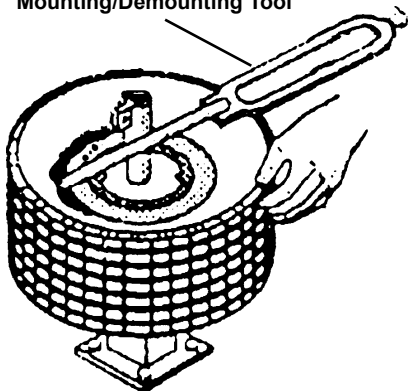
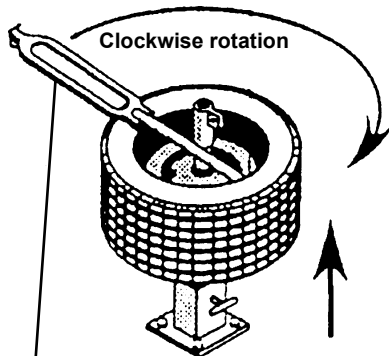

Figure E

15. Push Mounting/Demounting Tool's handle down, raising the bead above the rim. See Figure F.
16. With ball end still under the bead, pull handle of Mounting/Demounting Tool around clockwise. Hold tire to prevent it from turning. See Figure F.
17. Raise tire so that lower bead is just under the upper lip of the rim. See Figure F.



Mounting/Demounting Tool
Figure F

18. Position the ball end of Mounting/Demounting Tool under lower bead of tire.
19. Push down on handle to push lower bead above the rim.
20. Pull Mounting/Demounting Tool's handle clockwise to remove bottom bead from the rim.

PITTSBURGH®

Installing Tire

1. To mount a new or repaired tire, lubricate the inside and outside both tire beads.
2. Push the lower bead onto the rim as far as it will go without forcing it. See Figure G.

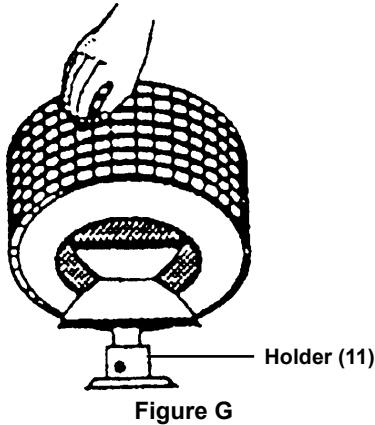

Note: With proper use of tire mounting lubricant, the first bead should slide complete onto the rim. In cases where it does not, use the Mounting/Demounting Tool to install the first bead.

3. Place the cut-out center of the Mounting/Demounting Tool over the Locking Nut. See Figure H.

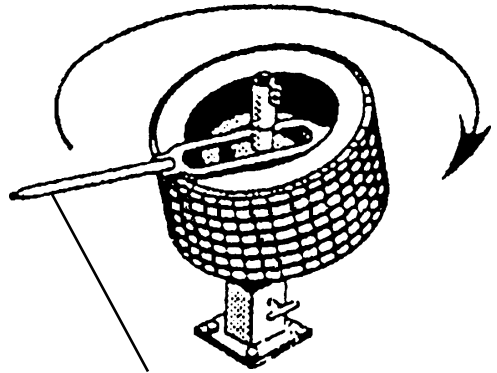

Mounting/Demounting Tool
Figure H

4. Pull the hook at the end of the Mounting/Demounting Tool snug against the edge of the tire rim.
5. Push the tire down at a spot opposite the hook of the Mounting/Demounting Tool. See Figure H.
6. Hold the tire to keep it from turning while pulling the Mounting/Demounting Tool clockwise. This will force the bead over the rim's upper edge. See Figure I.

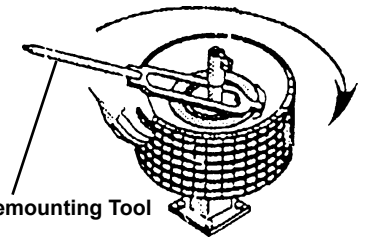

Mounting/Demounting Tool
Figure I

7. Once the lower bead is completely over the edge of the rim, install the upper bead, by following Steps 2-6, as described above.
8. Remove the Mounting/Demounting Tool when the tire is on the rim.

Maintenance Instructions

1. After each use, wipe any excess bead oil off of Mini-Tire Changer.
2. Regularly inspect Mini-Tire Changer to ensure that all connections are secure.

Parts List and Diagram

Part	Description	Qty
1	Alignment Disc	1
2	3" Spacer	2
3	Locking Nut	1
4	Breaker Handle	1
5	Forcing Handle	1
6	Pin	2
7	Mounting/Demounting Tool	1
8	Grip	1
9	Base Pin	1
10	Base	1
11	Holder	1
12	Protector Ring	1
13	Threaded Shaft	1
14	Handle Sleeve	1

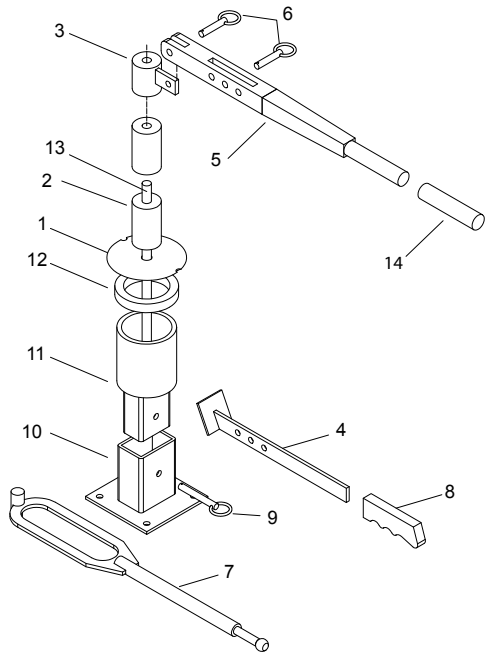

Record Serial Number Here: _____

Note: If product has no serial number, record month and year of purchase instead.

Note: Some parts are listed and shown for illustration purposes only, and are not available individually as replacement parts. Specify UPC 193175541697 when ordering parts.

PLEASE READ THE FOLLOWING CAREFULLY

THE MANUFACTURER AND/OR DISTRIBUTOR HAS PROVIDED THE PARTS LIST AND ASSEMBLY DIAGRAM IN THIS DOCUMENT AS A REFERENCE TOOL ONLY. NEITHER THE MANUFACTURER OR DISTRIBUTOR MAKES ANY REPRESENTATION OR WARRANTY OF ANY KIND TO THE BUYER THAT HE OR SHE IS QUALIFIED TO MAKE ANY REPAIRS TO THE PRODUCT, OR THAT HE OR SHE IS QUALIFIED TO REPLACE ANY PARTS OF THE PRODUCT. IN FACT, THE MANUFACTURER AND/OR DISTRIBUTOR EXPRESSLY STATES THAT ALL REPAIRS AND PARTS REPLACEMENTS SHOULD BE UNDERTAKEN BY CERTIFIED AND LICENSED TECHNICIANS, AND NOT BY THE BUYER. THE BUYER ASSUMES ALL RISK AND LIABILITY ARISING OUT OF HIS OR HER REPAIRS TO THE ORIGINAL PRODUCT OR REPLACEMENT PARTS THERETO, OR ARISING OUT OF HIS OR HER INSTALLATION OF REPLACEMENT PARTS THERETO.

Limited 90 Day Warranty

Harbor Freight Tools Co. makes every effort to assure that its products meet high quality and durability standards, and warrants to the original purchaser that this product is free from defects in materials and workmanship for the period of 90 days from the date of purchase. This warranty does not apply to damage due directly or indirectly, to misuse, abuse, negligence or accidents, repairs or alterations outside our facilities, criminal activity, improper installation, normal wear and tear, or to lack of maintenance. We shall in no event be liable for death, injuries to persons or property, or for incidental, contingent, special or consequential damages arising from the use of our product. Some states do not allow the exclusion or limitation of incidental or consequential damages, so the above limitation of exclusion may not apply to you. THIS WARRANTY IS EXPRESSLY IN LIEU OF ALL OTHER WARRANTIES, EXPRESS OR IMPLIED, INCLUDING THE WARRANTIES OF MERCHANTABILITY AND FITNESS.

To take advantage of this warranty, the product or part must be returned to us with transportation charges prepaid. Proof of purchase date and an explanation of the complaint must accompany the merchandise. If our inspection verifies the defect, we will either repair or replace the product at our election or we may elect to refund the purchase price if we cannot readily and quickly provide you with a replacement. We will return repaired products at our expense, but if we determine there is no defect, or that the defect resulted from causes not within the scope of our warranty, then you must bear the cost of returning the product.

This warranty gives you specific legal rights and you may also have other rights which vary from state to state.

PITTSBURGH[®]