

# Owner's Manual & Safety Instructions

Save This Manual Keep this manual for the safety warnings and precautions, assembly, operating, inspection, maintenance and cleaning procedures. Write the product's serial number in the back of the manual (or month and year of purchase if product has no number). Keep this manual and the receipt in a safe and dry place for future reference.

22i

# DAYTONA™ 3600 LB PINCH WELD VEHICLE DOLLIES

## DPD-180

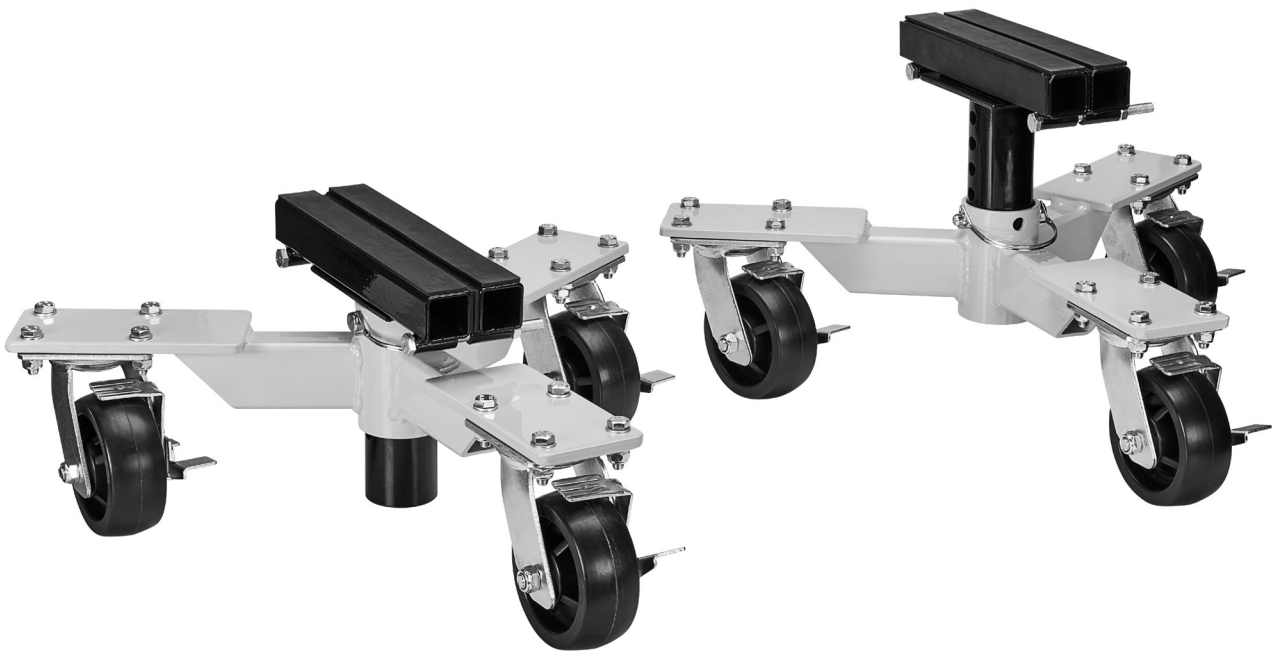

Visit our website at: <http://www.harborfreight.com>  
Email our technical support at: [productsupport@harborfreight.com](mailto:productsupport@harborfreight.com)

58986





When unpacking, make sure that the product is intact and undamaged. If any parts are missing or broken, please call 1-888-866-5797 as soon as possible.

Copyright© 2022 by Harbor Freight Tools®. All rights reserved.  
No portion of this manual or any artwork contained herein may be reproduced in any shape or form without the express written consent of Harbor Freight Tools. Diagrams within this manual may not be drawn proportionally. Due to continuing improvements, actual product may differ slightly from the product described herein.  
Tools required for assembly and service may not be included.

## ⚠ WARNING

Read this material before using this product.  
Failure to do so can result in serious injury.  
**SAVE THIS MANUAL.**

## WARNING SYMBOLS AND DEFINITIONS

	This is the safety alert symbol. It is used to alert you to potential personal injury hazards. Obey all safety messages that follow this symbol to avoid possible injury or death.
	Indicates a hazardous situation which, if not avoided, will result in death or serious injury.
	Indicates a hazardous situation which, if not avoided, could result in death or serious injury.
	Indicates a hazardous situation which, if not avoided, could result in minor or moderate injury.
	Addresses practices not related to personal injury.

## IMPORTANT SAFETY INFORMATION

Failure to heed these markings may result in personal injury and/or property damage:

1. Study, understand, and follow all instructions before operating the device.
2. Do not exceed rated capacity.
3. Use only on a hard, level surface capable of supporting the load.
4. Activate the wheel- and/or caster-locking devices after moving a vehicle.
5. Never work on, around, or under a vehicle supported by vehicle-moving dollies.
6. Use of this product is limited to transporting only.
7. No alterations shall be made to this product.
8. Before moving a load, assure that the load is centered and secured with the saddles clamped on the vehicle pinch welds. Confirm that the saddles are fully engaged on the vehicle pinch welds and all swivel caster wheels are contacting the ground.
9. Wear ANSI-approved safety goggles and heavy-duty work gloves during use.
10. Keep clear of load's path while placing on and removing from dollies, and while moving.
11. Use as intended only. Do not use for aircraft purposes. **Use only in pairs.**
12. Inspect before every use; do not use if parts are loose or damaged.
13. Be aware of dynamic loading! Sudden load movement may briefly create excess load causing product failure.
14. Assemble only according to these instructions. Improper assembly can create hazards.
15. Keep your work area clean and well lit. Cluttered work areas invite accidents.
16. Keep bystanders, children, and visitors away while operating Dolly. Distractions can cause you to lose control.
17. Stay alert. Watch what you are doing, and use common sense when operating Dollies. Do not use while tired or under the influence of drugs, alcohol, or medication. A moment of inattention while operating Dollies may result in serious personal injury.
18. Before use, read manufacturer's instruction manual for the vehicle you will lift.
19. Keep clear of load while lifting and lowering.
20. Lower load slowly.
21. Weight capacity and other product capabilities apply to properly and completely assembled product only.
22. Store idle Dollies out of reach of children and other untrained persons. Jacks are dangerous in the hands of untrained users.
23. Dolly service must be performed only by qualified repair personnel. Service or maintenance performed by unqualified personnel could result in a risk of injury.
24. Industrial applications must follow OSHA requirements.
25. Do not allow anyone in the vehicle while using the Dolly. Do not start the vehicle while it is on Dollies. Keep all bystanders a safe distance away from the vehicle.

26. This product is not a toy. Do not allow children to play with or near this item.
27. Maintain product labels and nameplates. These carry important safety information. If unreadable or missing, contact Harbor Freight Tools for a replacement.
28. The warnings, precautions, and instructions discussed in this manual cannot cover all possible conditions and situations that may occur. The operator must understand that common sense and caution are factors, which cannot be built into this product, but must be supplied by the operator.
29. **Do not roll while loaded over rough surfaces, such as concrete seams.** Use on flat, level, hard surface only. Wheels may scratch or dig into less durable surfaces (such as linoleum or wood).



**SAVE THESE INSTRUCTIONS.**

## Specifications

Rated Capacity	3600 lb (1800 lb each)
Adjustable Height	10" - 14"
Adjustable Saddle Width	0" - 1"

***DAYTONA***<sup>TM</sup>

# Functions

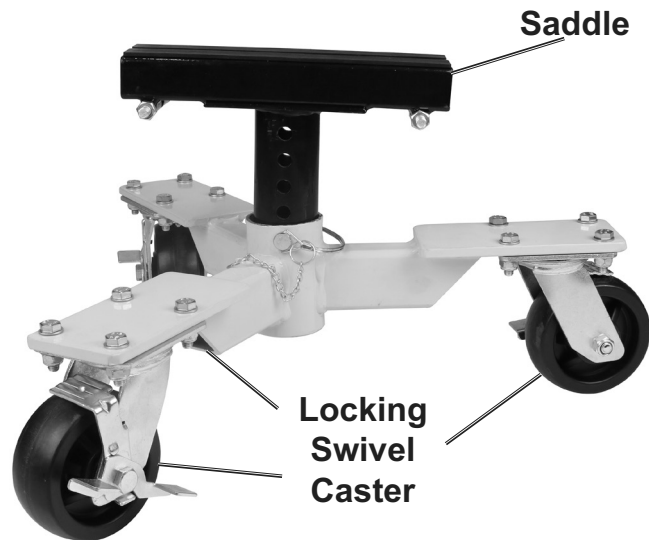

## Assembly Instructions



Read the **ENTIRE IMPORTANT SAFETY INFORMATION** section at the beginning of this document including all text under subheadings therein before set up or use of this product.

1. Assemble on a flat, level, hard and smooth surface.
2. Attach each Caster to the Base with Caster Bolts (x4), Washers (x8), and secure with Caster Nuts (x4).
3. Assemble Saddle Head Slide onto the Saddle Head using Saddle Bolts and Saddle Nuts.
4. Insert Saddle assembly into the Base, line up holes and slide Lock Pin into place. Secure with Loop Wire Lock.

**Note:** One washer under the bolt head, another washer between nut and caster plate.

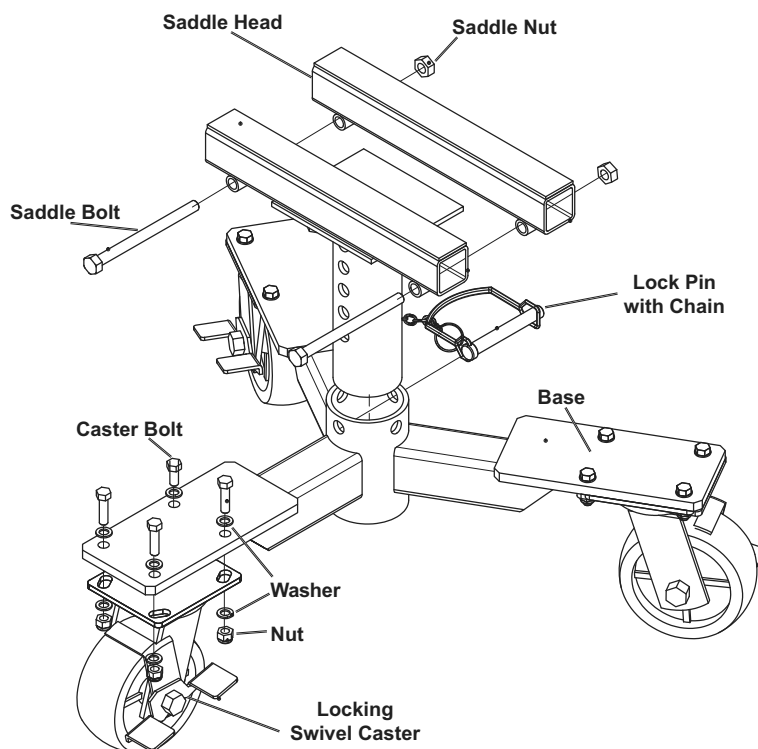

5. Make sure one end of the Chain is secured to the Lock Pin. Loop the Split Ring through the hole on the end of the lock Pin.

6. Attach the other end of the Chain to the Metal Loop on the Base. Loop the Split Ring through the Metal Loop.

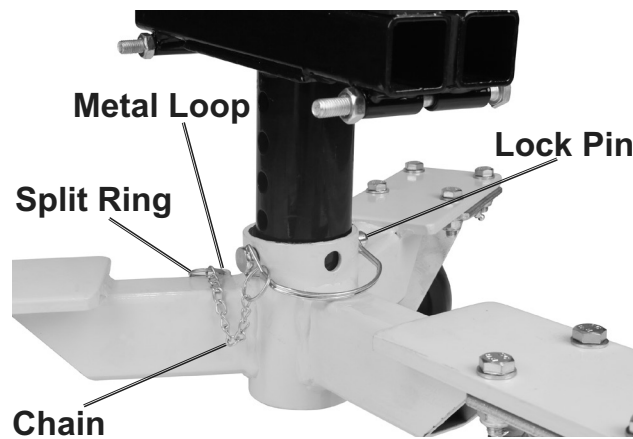

## Operating Instructions



Read the **ENTIRE IMPORTANT SAFETY INFORMATION** section at the beginning of this manual including all text under subheadings therein before set up or use of this product.

**WARNING! TO PREVENT SERIOUS INJURY:** Be ready for any movement the vehicle may make when the tires come off the ground. Ensure that you have sufficient assistance and manpower to safely guide and control the vehicle.

**WARNING! TO PREVENT SERIOUS INJURY:** Stay clear of any sloping areas or entry ramps, however shallow they may appear. Sufficient space should be allowed between the side of the vehicle and an adjacent wall for the vehicle to be withdrawn from its location in a sideways manner.

1. Lift vehicle high enough to roll the Dollies underneath.

**Note:** Place one Dolly on each side of the vehicle body under the frame pinch weld.

2. Remove the Lock Pin and raise the Saddle to the necessary height, then re-insert Lock Pin and secure with Loop Wire Lock.

3. Align the Saddle opening with the pinch weld.

4. Loosen the Saddle Bolts and open the Saddle wide enough for the frame pinch weld to fit into the openings.

5. Begin slowly lowering the vehicle body onto the Saddles.

**Note:** Check that the pinch welds are properly lined up with the Saddle openings before lowering completely.

6. Lower the vehicle completely.

7. Secure the vehicle to the Dollies by tightening the Saddle Bolts.

8. Lock the Casters when the Dollies are in their final position by pressing all six Caster Locks into the "ON" position.



## Inspection, Maintenance, And Cleaning



Procedures not specifically explained in this manual must be performed only by a qualified technician.

### **!WARNING**

#### **TO PREVENT SERIOUS INJURY FROM TOOL FAILURE:**

**Do not use damaged equipment. If abnormal noise or vibration occurs, have the problem corrected before further use.**

1. **BEFORE EACH USE**, inspect the general condition of the Dolly. Check for:
  - broken, cracked, or bent parts,
  - loose or missing parts,
  - and any condition that may affect the proper operation of the product.
2. **AFTER EVERY USE**, wipe with a clean cloth. Then, store the Dolly in a safe, dry location out of reach of children and other non-authorized people.
3. **PERIODICALLY**, Lubricate the Caster Swivel Bearings through the Grease Fittings.

## PLEASE READ THE FOLLOWING CAREFULLY

---

THE MANUFACTURER AND/OR DISTRIBUTOR HAS PROVIDED THE PARTS LIST AND ASSEMBLY DIAGRAM IN THIS DOCUMENT AS A REFERENCE TOOL ONLY. NEITHER THE MANUFACTURER OR DISTRIBUTOR MAKES ANY REPRESENTATION OR WARRANTY OF ANY KIND TO THE BUYER THAT HE OR SHE IS QUALIFIED TO MAKE ANY REPAIRS TO THE PRODUCT, OR THAT HE OR SHE IS QUALIFIED TO REPLACE ANY PARTS OF THE PRODUCT. IN FACT, THE MANUFACTURER AND/OR DISTRIBUTOR EXPRESSLY STATES THAT ALL REPAIRS AND PARTS REPLACEMENTS SHOULD BE UNDERTAKEN BY CERTIFIED AND LICENSED TECHNICIANS, AND NOT BY THE BUYER. THE BUYER ASSUMES ALL RISK AND LIABILITY ARISING OUT OF HIS OR HER REPAIRS TO THE ORIGINAL PRODUCT OR REPLACEMENT PARTS THERETO, OR ARISING OUT OF HIS OR HER INSTALLATION OF REPLACEMENT PARTS THERETO.

**Record Serial Number Here:**

---

**Note:** If product has no serial number, record month and year of purchase instead.

**Note:** Some parts are listed and shown for illustration purposes only, and are not available individually as replacement parts. Specify UPC 193175453778 when ordering parts.

## Parts List and Assembly Diagram

### Parts List

Part	Description	Qty
1	Saddle Nut	2
2	Saddle Head Slide	1
3	Saddle Head	1
4	Lock Pin	1
5	Base	1
6	Chain	1

Part	Description	Qty
7	Caster (with lock)	3
8	Caster Nut	12
9	Flat Washer	24
10	Caster Bolt (M10X35)	12
11	Saddle Bolt (M10X130)	2
12	Rubber Pad	2

### Assembly Drawing

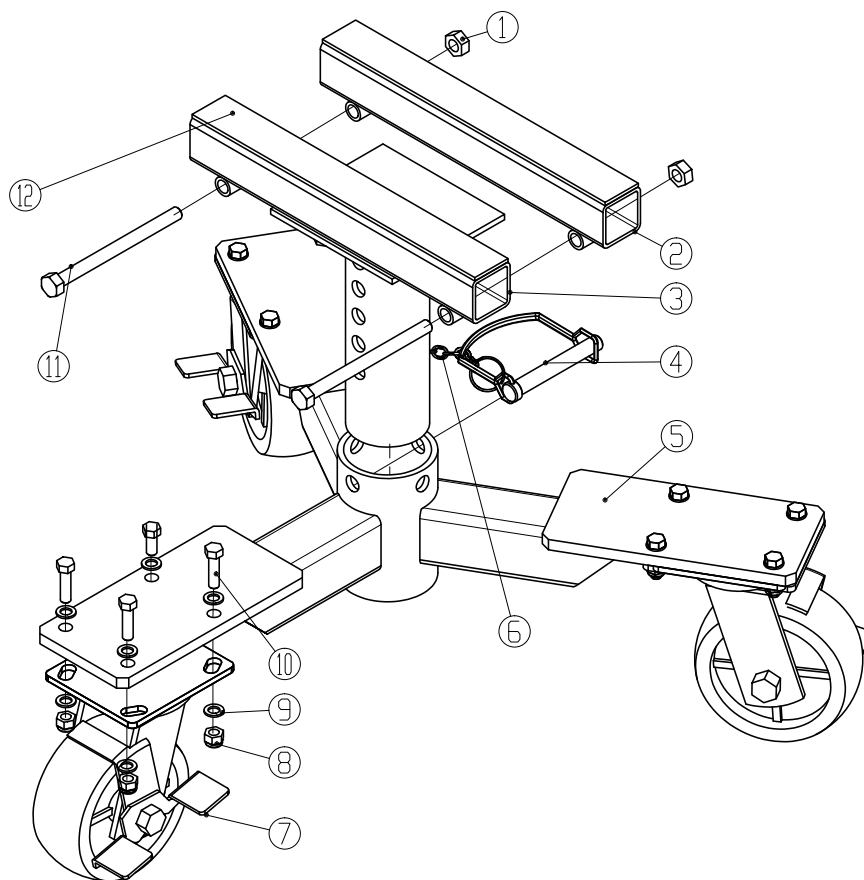

## Limited 90 Day Warranty

Harbor Freight Tools Co. makes every effort to assure that its products meet high quality and durability standards, and warrants to the original purchaser that this product is free from defects in materials and workmanship for the period of 90 days from the date of purchase. This warranty does not apply to damage due directly or indirectly, to misuse, abuse, negligence or accidents, repairs or alterations outside our facilities, criminal activity, improper installation, normal wear and tear, or to lack of maintenance. We shall in no event be liable for death, injuries to persons or property, or for incidental, contingent, special or consequential damages arising from the use of our product. Some states do not allow the exclusion or limitation of incidental or consequential damages, so the above limitation of exclusion may not apply to you. THIS WARRANTY IS EXPRESSLY IN LIEU OF ALL OTHER WARRANTIES, EXPRESS OR IMPLIED, INCLUDING THE WARRANTIES OF MERCHANTABILITY AND FITNESS.

To take advantage of this warranty, the product or part must be returned to us with transportation charges prepaid. Proof of purchase date and an explanation of the complaint must accompany the merchandise. If our inspection verifies the defect, we will either repair or replace the product at our election or we may elect to refund the purchase price if we cannot readily and quickly provide you with a replacement. We will return repaired products at our expense, but if we determine there is no defect, or that the defect resulted from causes not within the scope of our warranty, then you must bear the cost of returning the product.

This warranty gives you specific legal rights and you may also have other rights which vary from state to state.

# ***DAYTONA***<sup>TM</sup>

26677 Agoura Road • Calabasas, CA 91302 • 1-888-866-5797