

Owner's Manual & Safety Instructions

Save This Manual Keep this manual for the safety warnings and precautions, assembly, operating, inspection, maintenance and cleaning procedures. Write the product's serial number in the back of the manual near the assembly diagram (or month and year of purchase if product has no number). Keep this manual and the receipt in a safe and dry place for future reference.

21k

CENTRAL[®] MACHINERY

5" MULTIPURPOSE VISE

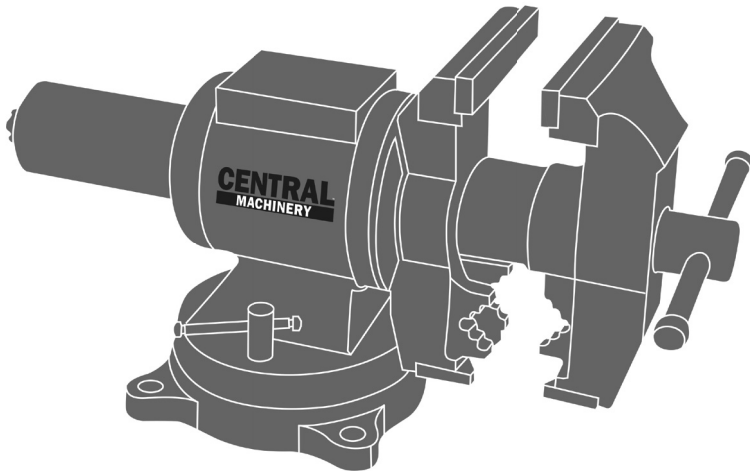

59275

Visit our website at: <http://www.harborfreight.com>
Email our technical support at: productsupport@harborfreight.com

When unpacking, make sure that the product is intact and undamaged. If any parts are missing or broken, please call 1-888-866-5797 as soon as possible.

Copyright © 2021 by Harbor Freight Tools[®]. All rights reserved.

No portion of this manual or any artwork contained herein may be reproduced in any shape or form without the express written consent of Harbor Freight Tools. Diagrams within this manual may not be drawn proportionally. Due to continuing improvements, actual product may differ slightly from the product described herein. Tools required for assembly and service may not be included.

⚠ WARNING

Read this material before using this product. Failure to do so can result in serious injury. **SAVE THIS MANUAL.**

Specifications

Jaw Throat Depth	2-3/4"
Pipe Jaw Capacity	2"
Swivel Capacity	360°

Important Safety Information

1. Mount according to these instructions before use. Improper mounting can create hazards.
2. Wear ANSI-approved safety goggles and heavy-duty work gloves during mounting and use.
3. Keep hands clear of Jaws.
4. Do not use additional leverage for tightening jaw grip. If required, use a larger vise.
5. Do not strike Vise with hardened tool. Inspect before use; discard if chipped.
6. Keep work area clean and well lit.
7. Keep bystanders out of the work area.
8. Do not use when tired or when under the influence of alcohol, drugs or medication.
9. This product is not a toy. Do not allow children to play with or near this item.
10. Use as intended only.
11. Inspect before every use; do not use if parts are loose or damaged.
12. Maintain product labels and nameplates. These carry important safety information. If unreadable or missing, contact Harbor Freight Tools for a replacement.
13. The warnings, precautions, and instructions discussed in this instruction manual cannot cover all possible conditions and situations that may occur. It must be understood by the operator that common sense and caution are factors which cannot be built into this product, but must be supplied by the operator.

Mounting Instructions



Read the **ENTIRE IMPORTANT SAFETY INFORMATION** section at the beginning of this document including all text under subheadings therein before set up or use of this product.

1. Vise must be mounted on a solid, level surface capable of supporting combined weight of Vise, workpieces, and applicable forces.
2. Use the holes in the base of the Vise as a template to mark the bench surface.
3. Drill holes and attach the Vise firmly to the work surface with appropriate hardware (1/2" hex bolts, flat washers, and nylon insert nuts, all sold separately).

WARNING! TO PREVENT SERIOUS INJURY: Verify that the installation surface has no hidden utility lines before drilling or driving screws.

CENTRAL[®]
MACHINERY

Operating Instructions



Read the **ENTIRE IMPORTANT SAFETY INFORMATION** section at the beginning of this document including all text under subheadings therein before set up or use of this product.

1. Turn the Handle to open the Jaws and place the workpiece between them.
2. Loosen Tilt Screw and rotate the Vise to the best orientation and pair of jaws for the job: Straight Jaws, Pipe Jaws or V-Jaws.
3. Tighten the Tilt Screw to secure the Vise before starting any work.
4. Close the Jaws until the workpiece is held securely. Do not overtighten the Jaws. Overtightening the Jaws could damage the workpiece.

Note: Use padding when necessary to prevent workpiece damage.

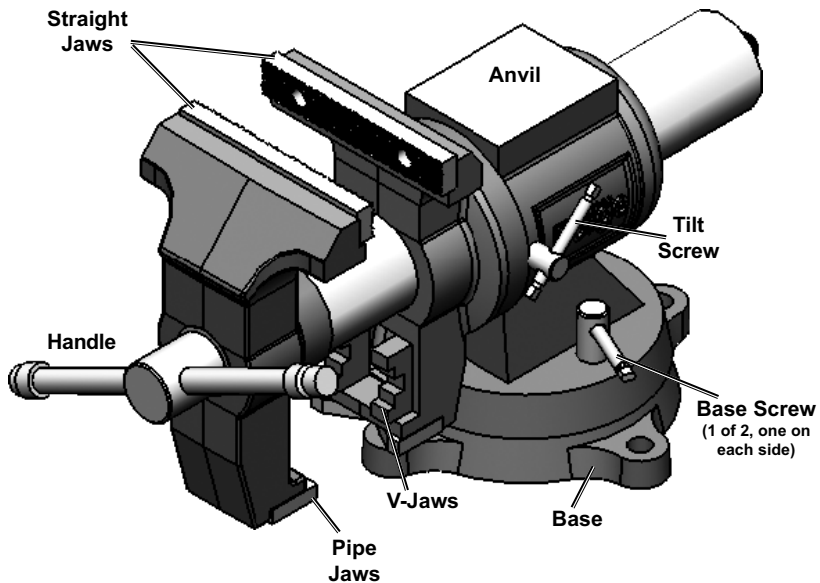

Maintenance and Servicing



Procedures not specifically explained in this manual must be performed only by a qualified technician.

1. **BEFORE EACH USE**, inspect the general condition of the tool. Check for misalignment or binding of moving parts, cracked or broken parts and any other condition that may affect its safe operation.
2. **AFTER USE**, clean external surfaces of the tool with clean cloth.
3. Lubricate the moving parts of the Vise periodically with a high quality machine oil.

CENTRAL[®]
MACHINERY

Parts List and Diagram

PLEASE READ THE FOLLOWING CAREFULLY

THE MANUFACTURER AND/OR DISTRIBUTOR HAS PROVIDED THE PARTS LIST AND ASSEMBLY DIAGRAM IN THIS MANUAL AS A REFERENCE TOOL ONLY. NEITHER THE MANUFACTURER OR DISTRIBUTOR MAKES ANY REPRESENTATION OR WARRANTY OF ANY KIND TO THE BUYER THAT HE OR SHE IS QUALIFIED TO MAKE ANY REPAIRS TO THE PRODUCT, OR THAT HE OR SHE IS QUALIFIED TO REPLACE ANY PARTS OF THE PRODUCT. IN FACT, THE MANUFACTURER AND/OR DISTRIBUTOR EXPRESSLY STATES THAT ALL REPAIRS AND PARTS REPLACEMENTS SHOULD BE UNDERTAKEN BY CERTIFIED AND LICENSED TECHNICIANS, AND NOT BY THE BUYER. THE BUYER ASSUMES ALL RISK AND LIABILITY ARISING OUT OF HIS OR HER REPAIRS TO THE ORIGINAL PRODUCT OR REPLACEMENT PARTS THERETO, OR ARISING OUT OF HIS OR HER INSTALLATION OF REPLACEMENT PARTS THERETO.

Parts List

Part	Description	Qty
1	Handle	1
2	Vise Screw	1
3	Adjusting Jaw	1
4	Straight Jaw	2
5	Straight Jaw Screw	4
6	Back Jaw	1
7	Base Screw	2
8	Housing	1
9	Cap	1
10	Washer	1

Part	Description	Qty
11	Cap Screw	2
12	Nut	1
13	Locking Pin	1
14	Pipe Jaw	1
15	Jaw Screw	3
16	V Jaw	1
17	Tilt Screw	1
18	Base	1
19	Rotation Ring	1

Record Serial Number Here: _____

Note: If product has no serial number, record month and year of purchase instead.

Note: Replacement parts are not available. Refer to UPC 193175464248.

Assembly Diagram

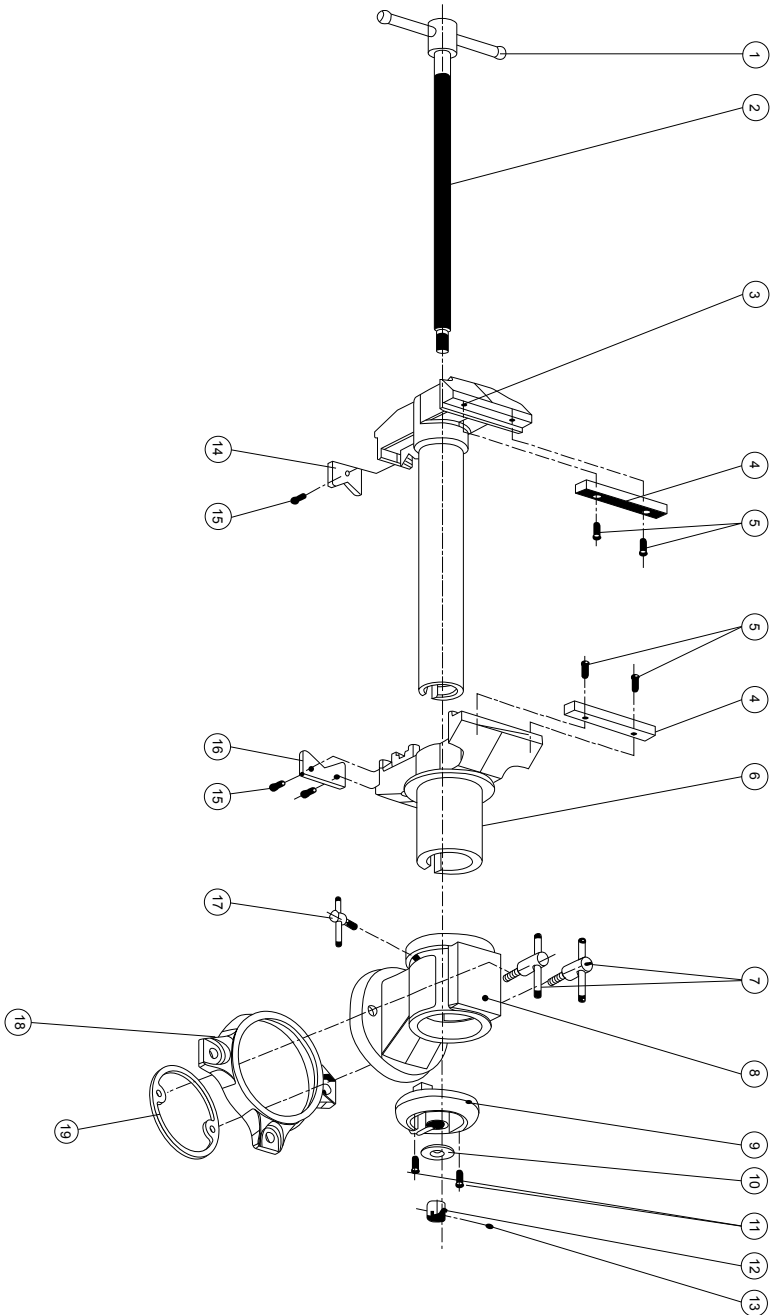

Limited 90 Day Warranty

Harbor Freight Tools Co. makes every effort to assure that its products meet high quality and durability standards, and warrants to the original purchaser that this product is free from defects in materials and workmanship for the period of 90 days from the date of purchase. This warranty does not apply to damage due directly or indirectly, to misuse, abuse, negligence or accidents, repairs or alterations outside our facilities, criminal activity, improper installation, normal wear and tear, or to lack of maintenance. We shall in no event be liable for death, injuries to persons or property, or for incidental, contingent, special or consequential damages arising from the use of our product. Some states do not allow the exclusion or limitation of incidental or consequential damages, so the above limitation of exclusion may not apply to you. THIS WARRANTY IS EXPRESSLY IN LIEU OF ALL OTHER WARRANTIES, EXPRESS OR IMPLIED, INCLUDING THE WARRANTIES OF MERCHANTABILITY AND FITNESS.

To take advantage of this warranty, the product or part must be returned to us with transportation charges prepaid. Proof of purchase date and an explanation of the complaint must accompany the merchandise. If our inspection verifies the defect, we will either repair or replace the product at our election or we may elect to refund the purchase price if we cannot readily and quickly provide you with a replacement. We will return repaired products at our expense, but if we determine there is no defect, or that the defect resulted from causes not within the scope of our warranty, then you must bear the cost of returning the product.

This warranty gives you specific legal rights and you may also have other rights which vary from state to state.

CENTRAL
MACHINERY