

Owner's Manual & Safety Instructions

Save This Manual Keep this manual for the safety warnings and precautions, assembly, operating, inspection, maintenance and cleaning procedures. Write the product's serial number in the back of the manual near the assembly diagram (or month and year of purchase if product has no number). Keep this manual and the receipt in a safe and dry place for future reference.

23d

BRAUN™

RECHARGEABLE LED WORK LIGHT



Visit our website at: <http://www.harborfreight.com>
Email our technical support at: productsupport@harborfreight.com

59374

When unpacking, make sure that the product is intact and undamaged. If any parts are missing or broken, please call 1-888-866-5797 as soon as possible.

Copyright© 2021 by Harbor Freight Tools®. All rights reserved.

No portion of this manual or any artwork contained herein may be reproduced in any shape or form without the express written consent of Harbor Freight Tools. Diagrams within this manual may not be drawn proportionally. Due to continuing improvements, actual product may differ slightly from the product described herein. Tools required for assembly and service may not be included.

⚠WARNING

Read this material before using this product. Failure to do so can result in serious injury. **SAVE THIS MANUAL.**

Specifications

Battery	3.7V 750mAh Rechargeable Li-Ion Battery
Lumens	200 (Flashlight) Low 85 / High 250 (LED Strip)
Bulb Type	LED
Charge Time	2.5 hours*
Run Time	6 hr (Flashlight) 11 hr (LED Strip low) 3 hr 30 min (LED Strip high)
Range	Up to 170 ft

*Note: Charge time will vary depending on the amp rating of the power source.

IMPORTANT SAFETY INFORMATION

⚠ WARNING

To prevent serious injury, FIRE, and EXPLOSION:

1. Keep dry.
2. Only use included charging adaptors. Other adaptors may damage tool or cause fire.
3. Do not submerge Light.
4. Do not operate in explosive atmospheres, such as in the presence of flammable liquids, gases, or dust.
5. People with pacemakers should consult their physician(s) before use. Electromagnetic fields in close proximity to heart pacemaker could cause pacemaker interference or pacemaker failure.
6. Not a toy. Keep out of reach of children.
7. Contains Li-Ion battery. Battery must be recycled or disposed of properly. Do not open, crush, heat above 140° F or incinerate.

Components

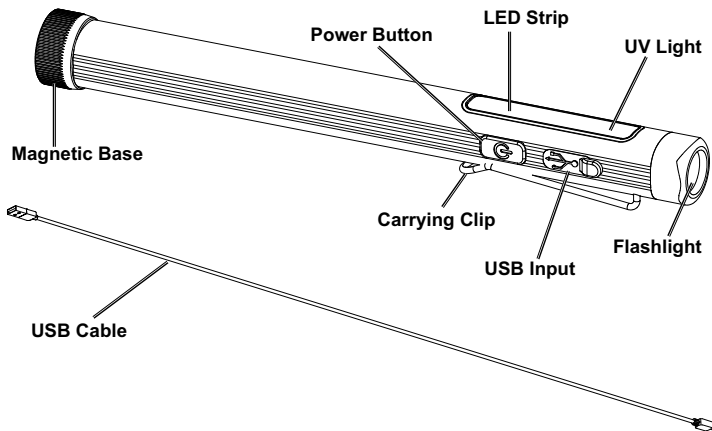

Charging Instructions



Read the **ENTIRE IMPORTANT SAFETY INFORMATION** section at the beginning of this document including all text under subheadings therein before set up or use of this product.

Note: Do not charge flashlight while in use.

1. Lift USB Port cover.
2. Insert the provided USB cable into USB port.
3. Insert the other end of the cable into power source.

4. After approximately 2.5 hours, the Flashlight is fully charged and ready for use. Unplug the Adaptor.

NOTICE: Do not leave the Battery in a discharged state. Charge the Battery every 3 months if the Flashlight is not in use. This will keep the Battery from wearing down and add to its life. Do not charge the Flashlight at temperatures below 40° F.

Operation Instructions



Read the **ENTIRE IMPORTANT SAFETY INFORMATION** section at the beginning of this document including all text under subheadings therein before set up or use of this product.

NOTE: Before using Flashlight for the first time, fully charge the Battery.

1. Press Power Button to turn Flashlight on.
2. Press Power Button again to switch to LED strip (low) mode.
3. Press Power Button again to switch to LED strip (high) mode.

4. Press Power Button again to switch to black light mode.
5. Press Power Button once more to turn flashlight off.
6. When finished using the Flashlight, store indoors away from children.

Battery Removal

1. Remove the caps on both ends of the flashlight.
2. Remove battery compartment from the flashlight housing.
3. Remove battery from the battery compartment by cutting wires.
4. Li-Ion BATTERY MUST BE RECYCLED OR DISPOSED OF PROPERLY.

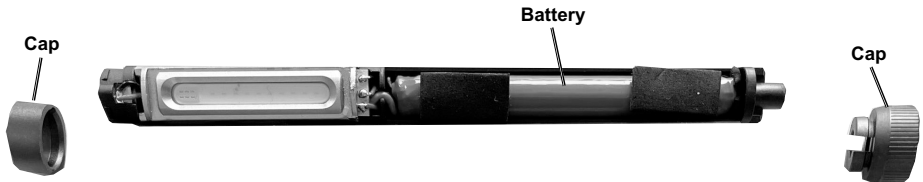

Record Serial Number Here:

Note: If product has no serial number, record month and year of purchase instead.

Note: Reference UPC 193175467942.

Limited 90 Day Warranty

Harbor Freight Tools Co. makes every effort to assure that its products meet high quality and durability standards, and warrants to the original purchaser that this product is free from defects in materials and workmanship for the period of 90 days from the date of purchase. This warranty does not apply to damage due directly or indirectly, to misuse, abuse, negligence or accidents, repairs or alterations outside our facilities, criminal activity, improper installation, normal wear and tear, or to lack of maintenance. We shall in no event be liable for death, injuries to persons or property, or for incidental, contingent, special or consequential damages arising from the use of our product. Some states do not allow the exclusion or limitation of incidental or consequential damages, so the above limitation of exclusion may not apply to you. THIS WARRANTY IS EXPRESSLY IN LIEU OF ALL OTHER WARRANTIES, EXPRESS OR IMPLIED, INCLUDING THE WARRANTIES OF MERCHANTABILITY AND FITNESS.

To take advantage of this warranty, the product or part must be returned to us with transportation charges prepaid. Proof of purchase date and an explanation of the complaint must accompany the merchandise. If our inspection verifies the defect, we will either repair or replace the product at our election or we may elect to refund the purchase price if we cannot readily and quickly provide you with a replacement. We will return repaired products at our expense, but if we determine there is no defect, or that the defect resulted from causes not within the scope of our warranty, then you must bear the cost of returning the product.

This warranty gives you specific legal rights and you may also have other rights which vary from state to state.

BRAUN™

26677 Agoura Road • Calabasas, CA 91302 • 1-888-866-5797