

# Owner's Manual & Safety Instructions

**Save This Manual** Keep this manual for the safety warnings and precautions, assembly, operating, inspection, maintenance and cleaning procedures. Write the product's serial number in the back of the manual (or month and year of purchase if product has no number). Keep this manual and the receipt in a safe and dry place for future reference.

22d



## 1/8 HP MULTI-DIRECTIONAL SUBMERSIBLE UTILITY PUMP



**Do not return  
pump to the store.  
Call 1-844-416-9141**

**59381**

Visit our website at: <http://www.harborfreight.com>  
Email our technical support at: [productsupport@harborfreight.com](mailto:productsupport@harborfreight.com)

When unpacking, make sure that the product is intact and undamaged. If any parts are missing or broken, please call 1-888-866-5797 as soon as possible.

Copyright© 2021 by Harbor Freight Tools®. All rights reserved.  
No portion of this manual or any artwork contained herein may be reproduced in any shape or form without the express written consent of Harbor Freight Tools. Diagrams within this manual may not be drawn proportionally. Due to continuing improvements, actual product may differ slightly from the product described herein.  
Tools required for assembly and service may not be included.

### **⚠ WARNING**

Read this material before using this product.  
Failure to do so can result in serious injury.  
**SAVE THIS MANUAL.**

## Before start-up, note the following:

---

The pump must be connected to a GFCI protected plug which has been installed according to regulations. The plug must have a supply voltage of 120 VAC at 60 Hz.

## CAUTION

---

This pump has been evaluated for use with water only.

## **⚠WARNING**

**IMPORTANT! For your own safety – before starting to run the pump, please have the following items checked by an expert:**

1. Risk of electric shock – This pump is supplied with a grounding conductor and grounding-type attachment plug. To reduce the risk of electric shock, be certain that it is connected only to a properly grounded, grounding-type receptacle.
2. Risk of electric shock – This pump has not been investigated for use in swimming pool areas.
3. The electrical connections must be protected from moisture.
4. If there is danger of flooding, the electrical connections must be taken to higher ground.
5. Circulation of caustic fluids, as well as the circulation of abrasive materials, must be avoided at all costs.
6. The pump must be protected from frost.
7. The pump must be protected from running dry.
8. Access by children should also be prevented with appropriate measures.
9.  **To prevent death from electric shock, pump must be connected only to a GFCI protected outlet.**
10. Do not use an extension cord with this item.
11. People with pacemakers should consult their physician(s) before use. Electromagnetic fields in close proximity to heart pacemaker could cause pacemaker interference or pacemaker failure.
12. The warnings, precautions, and instructions discussed in this instruction manual cannot cover all possible conditions and situations that may occur. It must be understood by the operator that common sense and caution are factors which cannot be built into this product, but must be supplied by the operator.

## Fluid Type

---

The Pump is designed for use with water with a maximum temperature of 95° F (35°C). Do not use the pump for other fluids, especially not fuels, cleaning fluids, or other chemical products.



## Specifications

Horsepower	1/8 HP
Electrical Rating	110-120VAC / 60Hz / 3.3A
Power Cord Length	10'
Maximum Flow @ 0'	1575 GPH
Maximum Head lift @ 0' Flow	24'
Discharge Port	1" NPT Female
Operating Water Depth	Minimum 3/16"
Maximum Water Temperature	95° F (35°C)



## Installation

The submersible motor pump must be installed in a stationary position with either:

- a. A fixed pipeline or
- b. A flexible hose.

## Please note!

1. Do not install the pump by suspending it unsupported from its power cord. The pump must be suspended from the handle or be placed on the bottom of the basin. To ensure that the pump works properly, keep the bottom free from sludge and dirt of all kinds.
2. If the water level sinks too low, any sludge in the basin will dry out and stop the pump from starting. To help ensure the pump will start as required, check the pump regularly with start-up tests.

## Power Supply

1. The pump is equipped with a shock-proof plug according to regulations. The pump is designed to be connected to 120 VAC, 60 Hz GFCI protected socket.
2. Make sure that the socket is sufficiently secured and is in excellent condition.
3. When the plug is inserted into the socket, the pump will be on standby.
4.  **WARNING: To prevent death from electric shock, pump must be connected only to a GFCI protected outlet.**

**WARNING! TO PREVENT SERIOUS INJURY:**  
If the power cord or plug is damaged, do not use the pump. The power cord or plug may only be repaired by a certified electrician.

## Areas of use

1. This pump is designed to pump clean water only.
2. This pump is designed to be used for:  
Removing water from flooded basements, window wells, garages, flat roofs.
3. This pump should NOT be used for:  
Continuous run, fountain/pond water features. Septic or sewage systems.

## Installation Instructions

1. Place Pump in water that is at least 3/16" deep.

**DANGER! Do not use an extension cord with this Pump. Keep plug dry and secured away from water.**

2. Attach Adapter to discharge port. Two adapters are included: Straight Adapter (38) and Elbow 90° Adapter (35).

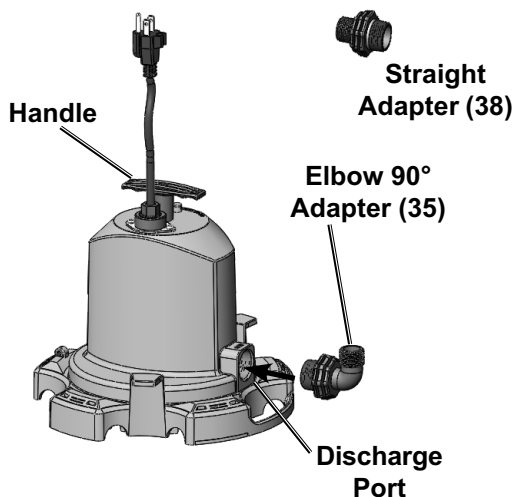

3. Connect discharge hose to Adapter.

**Note:** A Check Value (sold separately) may be used, if desired, and connects in-line with the discharge port and Adapter.

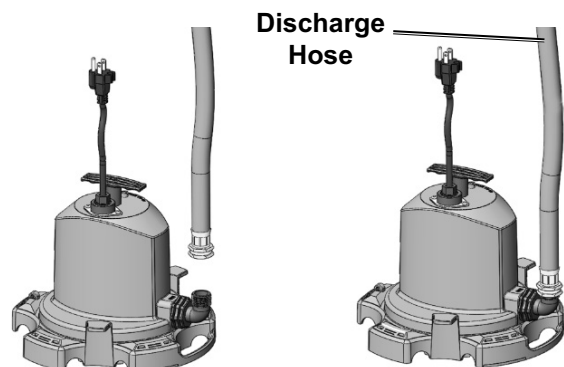

4. Place the other end of discharge hose as needed to direct the water discharge at least 3 feet away from the source. Keep it as straight as possible and secure it in place. Avoid walkways and hazards, prevent tripping and hose from being walked on, crushed or the outlet blocked.

## Operation

### **⚠ WARNING**

**TO PREVENT SERIOUS INJURY FROM ACCIDENTAL OPERATION:  
Unplug the Pump from its electrical outlet before setup or operation.**

1. After reading these instructions, consider the following points before starting the Pump:
  - a. Verify that the Pump rests upright and flat on the floor of the basin.
  - b. Verify that the discharge hose and Adapter are properly connected.
  - c. Verify that the electrical connection is 120 VAC, 60 Hz.
  - d. Verify that the electrical socket is GFCI protected and in good condition. Test GFCI protected outlet before use.
  - e. Verify that water and moisture cannot get near the power supply socket.
  - f. Verify that the Pump is installed so as to prevent it from running dry.
2. After the Pump and discharge hose are placed, connect the Power Cord into a 120 VAC, 60Hz GFCI protected outlet. Be sure the power cord reaches the outlet without any strain to the cord.

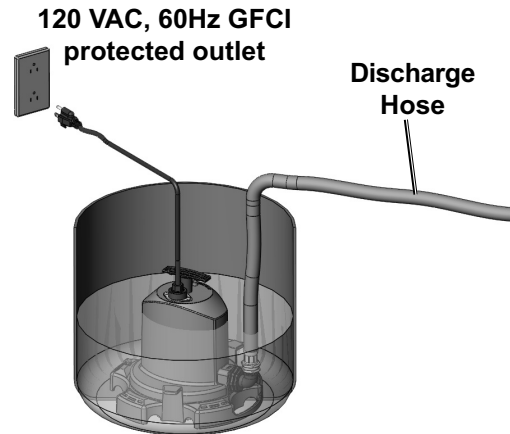

**Note:** The Pump must be in water at least 3/16" deep for it to operate properly.

**Note:** Do not allow the Pump to run dry. The Pump will remove water down to 3/16". Unplug the Pump once 3/16" water level is reached.

3. When finished using the Pump:
  - a. Disconnect power cord and wipe clean.
  - b. Remove discharge hose and allow it to dry completely.
  - c. Store indoors out of reach of children.

## Air and Water Release Valve

There is a check-ball valve built into the top of the pump, this valve will automatically release any captured air and water during the pumping process.

**Note:** The check-ball seal may allow a small trickle of water to flow from the Air and Water Release Valve, this is normal.

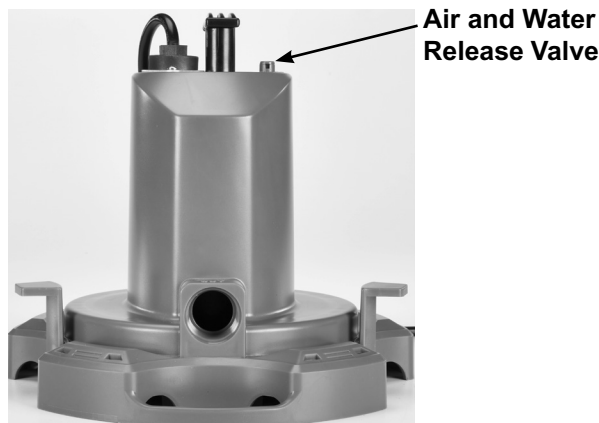

## Maintenance

### **⚠️ WARNING**

#### **TO PREVENT SERIOUS INJURY FROM ACCIDENTAL OPERATION:**

**Unplug the Pump from its electrical outlet before performing any inspection, maintenance, or cleaning procedure.**

If the Pump is moved during operation, flush it out with clean water after every use.

## Quarterly Maintenance

The below maintenance must be performed at least once every 3 months under optimal conditions. For frequent use, or dirty areas, more frequent maintenance is required.

1. Clean sludge and debris from the bottom of the basin.
2. Clean sludge/debris from inlet screen at the bottom of the Base.
3. If the Pump cannot be thoroughly cleaned from the outside, it must be partially dismantled. **Unplug the power cord before maintenance.** Dismantle the bottom of the Pump as follows:
  - a. Remove Screws (24) and Base (23).
  - b. Clean the Impeller (25) with clean water.
  - c. To prevent damage, do not rest the Pump on the Impeller or pry against the Impeller.
  - d. Reassemble in reverse order.
4. Flush the discharge hose and be sure it is free from leaks.
5. If Check Valve used, make sure it is functioning properly.

## Troubleshooting

Problem	Possible Causes	Possible Solutions
Pump runs, but will not deliver any water.	<ol style="list-style-type: none"> <li>1. Inlet Screen and/or Impeller clogged.</li> <li>2. When starting, the water height falls below the minimum level (3/16").</li> <li>3. Low line voltage.</li> <li>4. Check Valve (sold separately) stuck or installed backwards.</li> </ol>	<ol style="list-style-type: none"> <li>1. Remove Base. Clean dirt and debris from inlet screen and Impeller, then reinstall Base.</li> <li>2. The water must be at least 3/16" deep for the Pump to operate properly.</li> <li>3. Consult an electrician.</li> <li>4. Remove and examine Check Valve.</li> </ol>
Pump won't start or run.	<ol style="list-style-type: none"> <li>1. Check power connections, circuits/fuses.</li> <li>2. Water level too low.</li> <li>3. Inlet screen and/or Impeller clogged.</li> <li>4. Defective motor.</li> </ol>	<ol style="list-style-type: none"> <li>1. Consult an electrician.</li> <li>2. Allow water level to rise above 3/16" or move Pump to a lower location.</li> <li>3. Remove Base. Clean dirt and debris from inlet screen and Impeller, then reinstall Base.</li> <li>4. Have a qualified service technician repair or replace.</li> </ol>
Excessive noise/vibration.	<ol style="list-style-type: none"> <li>1. Debris in Impeller.</li> <li>2. Discharge hose restricted.</li> </ol>	<ol style="list-style-type: none"> <li>1. Remove Base and clean Impeller. Reinstall Base.</li> <li>2. Clean Pump and discharge hose.</li> </ol>
Pump starts/stops frequently.	<ol style="list-style-type: none"> <li>1. Water temperature too high.</li> <li>2. Back flow of water from discharge hose.</li> </ol>	<ol style="list-style-type: none"> <li>1. Do not exceed 95° F (35° C) water temperature.</li> <li>2. Install/inspect Check Valve (sold separately).</li> </ol>



**Follow all safety precautions whenever diagnosing or servicing the tool.  
Disconnect power supply before service.**

# PLEASE READ THE FOLLOWING CAREFULLY

THE MANUFACTURER AND/OR DISTRIBUTOR HAS PROVIDED THE PARTS LIST AND ASSEMBLY DIAGRAM IN THIS MANUAL AS A REFERENCE TOOL ONLY. NEITHER THE MANUFACTURER OR DISTRIBUTOR MAKES ANY REPRESENTATION OR WARRANTY OF ANY KIND TO THE BUYER THAT HE OR SHE IS QUALIFIED TO MAKE ANY REPAIRS TO THE PRODUCT, OR THAT HE OR SHE IS QUALIFIED TO REPLACE ANY PARTS OF THE PRODUCT. IN FACT, THE MANUFACTURER AND/OR DISTRIBUTOR EXPRESSLY STATES THAT ALL REPAIRS AND PARTS REPLACEMENTS SHOULD BE UNDERTAKEN BY CERTIFIED AND LICENSED TECHNICIANS, AND NOT BY THE BUYER. THE BUYER ASSUMES ALL RISK AND LIABILITY ARISING OUT OF HIS OR HER REPAIRS TO THE ORIGINAL PRODUCT OR REPLACEMENT PARTS THERETO, OR ARISING OUT OF HIS OR HER INSTALLATION OF REPLACEMENT PARTS THERETO.

## Parts List and Diagram

Part	Description	Qty.
1	Power Cord	1
2	Screw	7
3	Handle	1
4	Pump Housing	1
5	Steel Ball	1
6	Venting Plug	1
7	O-Ring	1
8	Screw	1
9	O-Ring	1
10	Motor Housing	1
11	Screw	5
12	Screw	1
13	Spring Washer	2
14	Earthing Terminal	1
15	Motor Back Cover	1
16	Gasket	1
17	Stator	1
18	Bearing	2
19	Circlip	2
20	O-Ring	1
21	Motor Front Cover	1

Part	Description	Qty.
22	Baseplate Liner	1
23	Base	1
24	Screw	6
25	Impeller	1
26	Oil Seal	2
27	Rotor Shaft	1
28	Rotor	1
29	Capacitance	1
30	Wiring Cap	2
31	Flat Gasket	1
32	Tubular Terminal	3
33	Screw	1
34	Gasket	1
35	Elbow 90° Adapter, 3/4"	1
36	O-Ring	1
37	Power Socket Clamp	1
38	Straight Adapter, 3/4"	1
39	Transformer Oil (not shown)	N/A
40	Vent Cover	1

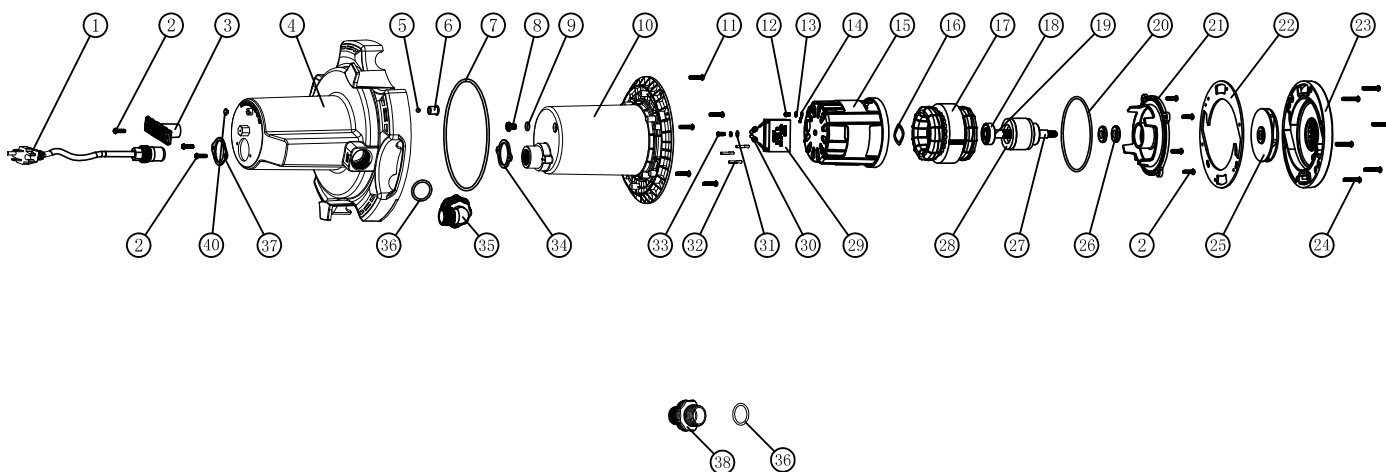

Record Product's Serial Number Here: \_\_\_\_\_

**Note:** If product has no serial number, record month and year of purchase instead.

**Note:** Some parts are listed and shown for illustration purposes only, and are not available individually as replacement parts. Specify UPC 193175468291 when ordering parts.

## Limited 90 Day Warranty

Harbor Freight Tools Co. makes every effort to assure that its products meet high quality and durability standards, and warrants to the original purchaser that this product is free from defects in materials and workmanship for the period of 90 days from the date of purchase. This warranty does not apply to damage due directly or indirectly, to misuse, abuse, negligence or accidents, repairs or alterations outside our facilities, criminal activity, improper installation, normal wear and tear, or to lack of maintenance. We shall in no event be liable for death, injuries to persons or property, or for incidental, contingent, special or consequential damages arising from the use of our product. Some states do not allow the exclusion or limitation of incidental or consequential damages, so the above limitation of exclusion may not apply to you. THIS WARRANTY IS EXPRESSLY IN LIEU OF ALL OTHER WARRANTIES, EXPRESS OR IMPLIED, INCLUDING THE WARRANTIES OF MERCHANTABILITY AND FITNESS.

To take advantage of this warranty, the product or part must be returned to us with transportation charges prepaid. Proof of purchase date and an explanation of the complaint must accompany the merchandise. If our inspection verifies the defect, we will either repair or replace the product at our election or we may elect to refund the purchase price if we cannot readily and quickly provide you with a replacement. We will return repaired products at our expense, but if we determine there is no defect, or that the defect resulted from causes not within the scope of our warranty, then you must bear the cost of returning the product.

This warranty gives you specific legal rights and you may also have other rights which vary from state to state.



26677 Agoura Road • Calabasas, CA 91302 • 1-888-866-5797