

# Owner's Manual & Safety Instructions

**Save This Manual** Keep this manual for the safety warnings and precautions, assembly, operating, inspection, maintenance and cleaning procedures. Write the product's serial number in the back of the manual (or month and year of purchase if product has no number). Keep this manual and the receipt in a safe and dry place for future reference.

22k

# **Bauer**™ **23503E-B**

## **1000 CFM FLOOR BLOWER**



Visit our website at: <http://www.harborfreight.com>  
Email our technical support at: [productsupport@harborfreight.com](mailto:productsupport@harborfreight.com)

**59429**

When unpacking, make sure that the product is intact and undamaged. If any parts are missing or broken, please call 1-888-866-5797 as soon as possible.

Copyright© 2022 by Harbor Freight Tools®. All rights reserved.  
No portion of this manual or any artwork contained herein may be reproduced in any shape or form without the express written consent of Harbor Freight Tools. Diagrams within this manual may not be drawn proportionally. Due to continuing improvements, actual product may differ slightly from the product described herein.  
Tools required for assembly and service may not be included.

## **⚠ WARNING**

Read this material before using this product.  
Failure to do so can result in serious injury.  
**SAVE THIS MANUAL.**







# READ AND SAVE THESE INSTRUCTIONS.

## RULES FOR SAFE OPERATION

1. **WARNING! To reduce the risk of fire or electric shock, do not use this Blower with any solid-state speed control device.**
2. **This appliance has a polarized plug (one blade is wider than the other). To reduce the risk of electric shock, this plug is intended to fit into a polarized outlet only one way. If the plug does not fit fully in the outlet, reverse the plug. If it still does not fit, contact a qualified electrician. Do not attempt to defeat this safety feature.**
3. **Do not leave Blower running while unattended.**
4. **Do not operate any blower with a damaged cord or plug. Discard blower or return to an authorized service facility for examination and/or repair.**
5. **Do not run cord under carpeting. Do not cover cord with throw rugs, runners, or similar coverings. Do not route cord under furniture or appliances. Arrange cord away from traffic area and where it will not be tripped over.**
6. Never insert fingers, pencils, or any other object through Front or Rear Blade Guards.
7. Disconnect Blower when moving it from one location to another.
8. Disconnect Blower before removing grills for cleaning.
9. Be sure blower is on a stable surface when operating to avoid overturning.
10. DO NOT use blower in window. Rain may create electrical hazard.
11. Complete the assembly of the blower before switching on the blower.
12. Maintain labels and nameplates on the Blower. If unreadable or missing, contact Harbor Freight Tools for a replacement.
13. Use only in dry areas. Do not use in bathrooms, laundry area, near sinks or other sources of water.
14. This Blower is not a toy. Keep it out of reach of children.
15. People with pacemakers should consult their physician(s) before use. Electromagnetic fields in close proximity to heart pacemaker could cause pacemaker interference or pacemaker failure.
16. The warnings, precautions, and instructions discussed in this instruction manual cannot cover all conditions and situations that may occur. It must be understood by operator that common sense and caution are factors which cannot be built into this Blower, but must be supplied by operator.

## WARNING SYMBOLS AND DEFINITIONS

	This is the safety alert symbol. It is used to alert you to potential personal injury hazards. Obey all safety messages that follow this symbol to avoid possible injury or death.
	Indicates a hazardous situation which, if not avoided, will result in death or serious injury.
	Indicates a hazardous situation which, if not avoided, could result in death or serious injury.
	Indicates a hazardous situation which, if not avoided, could result in minor or moderate injury.
	Addresses practices not related to personal injury.

# ***Bauer***<sup>TM</sup>

## Specifications

Electrical Rating	115VAC / 60Hz / 2.1A GFCI Receptacle Max. Load Current Rating: 9.5 A
Linkable Outlets	Two 115 VAC / 60Hz 12A Max combined when unit OFF 9.5A Max combined when unit ON
Horse Power	1/5
CFM	1000
3-Speed	High, Medium, Low
Power Cord Length	10ft.

**FOR COMMERCIAL USE**

# Functions

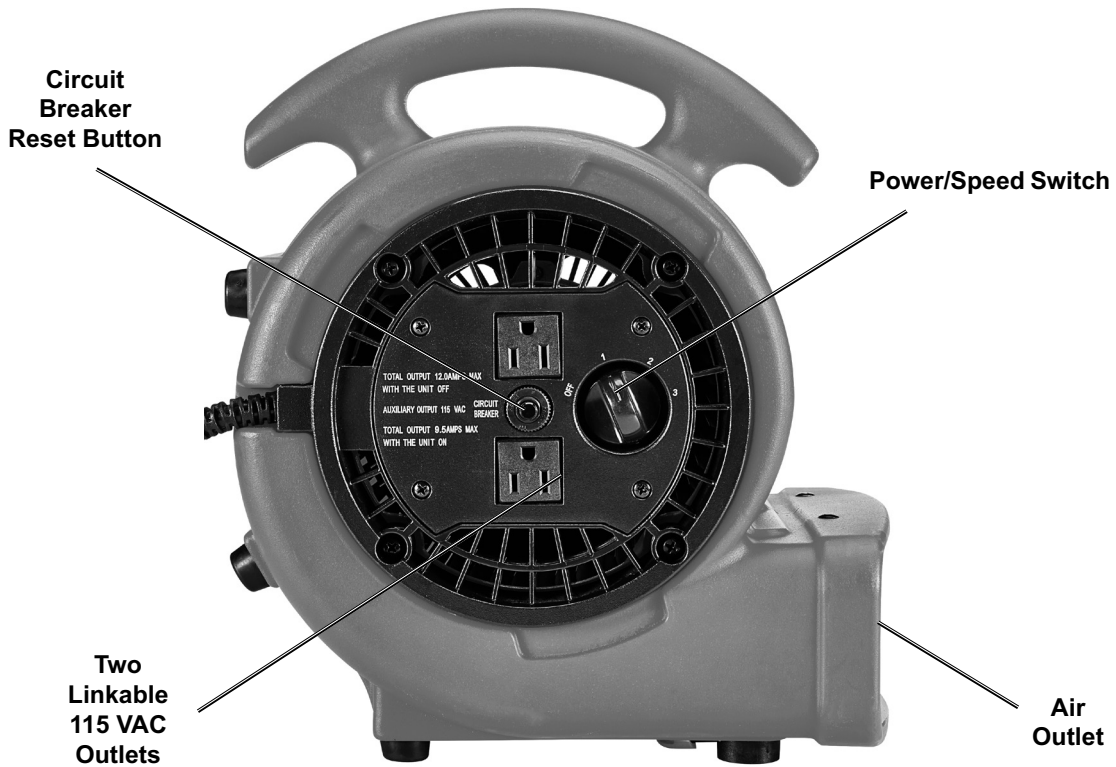

# Operation



Read the **ENTIRE RULES FOR SAFE OPERATION** section at the beginning of this manual including all text under subheadings therein before set up or use of this Blower.

1. Set the Power/Speed Switch to the "OFF" position.
2. Plug the Power Cord into a grounded GFCI-protected outlet.
3. Place the Blower on a level, firm base and position it as needed:
  - a. Horizontal

**Note:** The Kickstand may be pulled down to lift the front end of Blower. Return the Kickstand to its resting position when not in use.

- b. Tilted 15°



c. Tilted 45°



d. Vertical 90°



4. Leave adequate space around the Blower for unimpeded air flow. Air flows in at both sides of the Blower. **Do not allow dirt or debris to be drawn into the Blower.**
5. Rotate the Power/Speed Switch to the desired speed setting. To turn the blower off, rotate the Power/Speed Switch to the "OFF" position.

**Note:** If the Blower suddenly stops operating, the Overload Protection may have tripped. Make sure that the Blower is dry, that the air inlets/outlet are not obstructed, and that the Blower has cooled completely before pressing the Circuit Breaker Reset Button on the side of the unit and continuing to use the Blower.

6. Additional powered devices can be plugged into the two Auxiliary 115 VAC outlets on the side of the blower.
  - Do not exceed 12A combined current draw across the two outlets when the unit is OFF.
  - Do not exceed 9.5A combined current draw across the two outlets when the unit is ON.
7. To prevent accidents, turn off the Blower and unplug it after use. Clean, then store the Blower indoors out of children's reach.

# **Bauer**<sup>TM</sup>

## User Servicing Instructions



Procedures not specifically explained in this manual must be performed only by a qualified technician.

### **⚠️WARNING**

#### **TO PREVENT SERIOUS INJURY FROM ACCIDENTAL OPERATION OR ELECTRIC SHOCK:**

Turn the Power/Speed Switch of the Blower off, unplug the Blower from its electrical outlet, and allow the Blower to cool completely before performing any inspection, maintenance, or cleaning procedures.

#### **TO PREVENT SERIOUS INJURY FROM BLOWER FAILURE:**

Do not use damaged equipment. If abnormal noise or vibration occurs, have the problem corrected before further use.

1. **BEFORE EACH USE**, inspect the general condition of the Blower. Check for:
  - loose hardware,
  - misalignment or binding of moving parts,
  - cracked or broken parts,
  - damaged electrical wiring, and
  - any other condition that may affect its safe operation.
2. Clean outside housing regularly to prevent dust from accumulating in the air inlets/outlet. Use damp cloth during cleaning and dry before use. **Do not open housing for cleaning or any other reason.**
3. **⚠️WARNING! TO PREVENT SERIOUS INJURY: If the supply cord of this Blower is damaged, it must be replaced only by a qualified service technician.**

## If Blower suddenly stops operating

The Overload Protection may have tripped.

Before pressing the Circuit Breaker Reset Button and continuing to use the Blower, make sure:

- that the Blower is dry,
- that the air inlets/outlet are not obstructed, and
- that the Blower has cooled completely.

**Record Serial Number Here:** \_\_\_\_\_

**Note:** If Blower has no serial number, record month and year of purchase instead.

**Note:** Some parts are listed and shown for illustration purposes only, and are not available individually as replacement parts. Specify UPC 193175470744 when ordering parts.

# PLEASE READ THE FOLLOWING CAREFULLY

THE MANUFACTURER AND/OR DISTRIBUTOR HAS PROVIDED THE PARTS LIST AND ASSEMBLY DIAGRAM IN THIS MANUAL AS A REFERENCE TOOL ONLY. NEITHER THE MANUFACTURER OR DISTRIBUTOR MAKES ANY REPRESENTATION OR WARRANTY OF ANY KIND TO THE BUYER THAT HE OR SHE IS QUALIFIED TO MAKE ANY REPAIRS TO THE PRODUCT, OR THAT HE OR SHE IS QUALIFIED TO REPLACE ANY PARTS OF THE PRODUCT. IN FACT, THE MANUFACTURER AND/OR DISTRIBUTOR EXPRESSLY STATES THAT ALL REPAIRS AND PARTS REPLACEMENTS SHOULD BE UNDERTAKEN BY CERTIFIED AND LICENSED TECHNICIANS, AND NOT BY THE BUYER. THE BUYER ASSUMES ALL RISK AND LIABILITY ARISING OUT OF HIS OR HER REPAIRS TO THE ORIGINAL PRODUCT OR REPLACEMENT PARTS THERETO, OR ARISING OUT OF HIS OR HER INSTALLATION OF REPLACEMENT PARTS THERETO.

## Parts List and Diagram

Part	Description	Qty
1	Inlet Grill	1
2	Fan Wheel	1
3	Fan Housing	1
4	Rubber Feet	8
5	Motor	1
6	Motor Bracket	1
7	Capacitor	1
8	Power Cord	1

Part	Description	Qty
9	Switch Cover	1
10	Power/Speed Switch	1
11	Switch Panel	1
12	Power Outlet	2
13	Switch Knob	1
14	Circuit Breaker	1
15	Outlet Grill	1

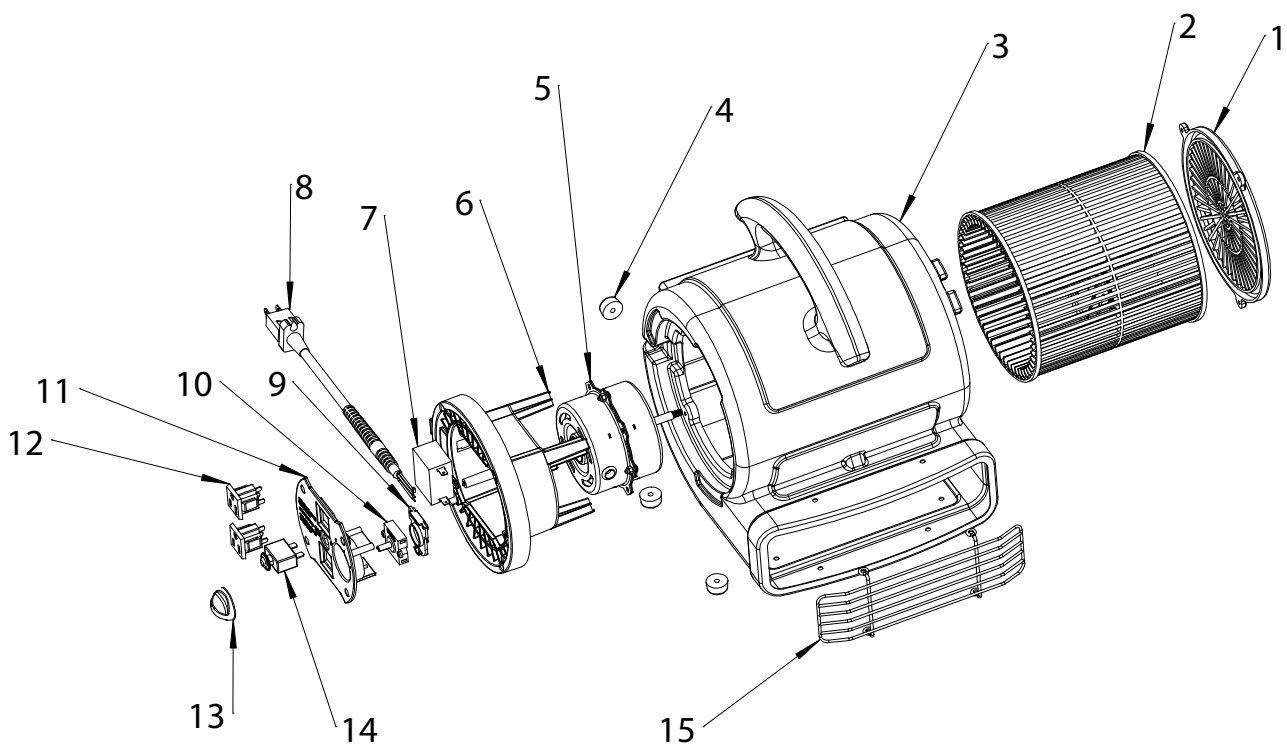

## Limited 90 Day Warranty

Harbor Freight Tools Co. makes every effort to assure that its products meet high quality and durability standards, and warrants to the original purchaser that this product is free from defects in materials and workmanship for the period of 90 days from the date of purchase. This warranty does not apply to damage due directly or indirectly, to misuse, abuse, negligence or accidents, repairs or alterations outside our facilities, criminal activity, improper installation, normal wear and tear, or to lack of maintenance. We shall in no event be liable for death, injuries to persons or property, or for incidental, contingent, special or consequential damages arising from the use of our product. Some states do not allow the exclusion or limitation of incidental or consequential damages, so the above limitation of exclusion may not apply to you. THIS WARRANTY IS EXPRESSLY IN LIEU OF ALL OTHER WARRANTIES, EXPRESS OR IMPLIED, INCLUDING THE WARRANTIES OF MERCHANTABILITY AND FITNESS.

To take advantage of this warranty, the product or part must be returned to us with transportation charges prepaid. Proof of purchase date and an explanation of the complaint must accompany the merchandise. If our inspection verifies the defect, we will either repair or replace the product at our election or we may elect to refund the purchase price if we cannot readily and quickly provide you with a replacement. We will return repaired products at our expense, but if we determine there is no defect, or that the defect resulted from causes not within the scope of our warranty, then you must bear the cost of returning the product.

This warranty gives you specific legal rights and you may also have other rights which vary from state to state.

The logo for Bauer, featuring the word "Bauer" in a bold, italicized, sans-serif font. The letters are black with a white outline, and a small trademark symbol (TM) is located at the bottom right of the letter "r".

26677 Agoura Road • Calabasas, CA 91302 • 1-888-866-5797