

Owner's Manual & Safety Instructions

Save This Manual Keep this manual for the safety warnings and precautions, assembly, operating, inspection, maintenance and cleaning procedures. Write the product's serial number in the back of the manual near the assembly diagram (or month and year of purchase if product has no number). Keep this manual and the receipt in a safe and dry place for future reference.

23b

7 FUNCTION DIGITAL MULTIMETER

59434



Visit our website at: <http://www.harborfreight.com>
Email our technical support at: productsupport@harborfreight.com

When unpacking, make sure that the product is intact and undamaged. If any parts are missing or broken, please call 1-888-866-5797 as soon as possible.

Copyright© 2022 by Harbor Freight Tools®. All rights reserved.

No portion of this manual or any artwork contained herein may be reproduced in any shape or form without the express written consent of Harbor Freight Tools. Diagrams within this manual may not be drawn proportionally. Due to continuing improvements, actual product may differ slightly from the product described herein. Tools required for assembly and service may not be included.

⚠ WARNING

**Read this material before using this product.
Failure to do so can result in serious injury.
SAVE THIS MANUAL.**

Table of Contents

Safety	2	Operation	7
Specifications	5	Maintenance	11
Setup	6	Warranty	12

WARNING SYMBOLS AND DEFINITIONS

	This is the safety alert symbol. It is used to alert you to potential personal injury hazards. Obey all safety messages that follow this symbol to avoid possible injury or death.
⚠ DANGER	Indicates a hazardous situation which, if not avoided, will result in death or serious injury.
⚠ WARNING	Indicates a hazardous situation which, if not avoided, could result in death or serious injury.
⚠ CAUTION	Indicates a hazardous situation which, if not avoided, could result in minor or moderate injury.
NOTICE CAUTION	Addresses practices not related to personal injury.

IMPORTANT SAFETY INFORMATION

Safety Warnings and Precautions

⚠ WARNING

Read all safety warnings and all instructions.

Failure to follow the warnings and instructions may result in electric shock, fire and/or serious injury.

Save all warnings and instructions for future reference.

1. Electrical shock can cause death or injury! NEVER TOUCH exposed conductors of electricity.
2. Inspect the Multimeter before use. In addition to a general inspection, look specifically for:
 - a. Pay special attention to the insulation protecting the connectors.
 - b. Check the leads for exposed metal, damaged insulation, and continuity.
 - c. Replace damaged test lead immediately, before use.
3. Do not use the Multimeter if:
 - a. Either of the test leads are damaged in any way.
 - b. Test leads are dirty or have residue on them.
 - c. The battery is low.
 - d. Near any explosive gasses or fumes.
 - e. Any abnormal operation is detected.
(If in doubt about the condition of the Meter, have it serviced before use).

4. Power this Meter using only the battery(ies) referenced in the Specifications Chart.
5. Use caution when working near voltages above 30 VAC rms, 42 VAC peak, or 60 VDC. Voltages this high present a risk of electric shock.
6. Disconnect the circuit's power before connecting the Meter in series, when measuring current.
7. Connect the common (COM) test lead first and disconnect it last.
8. Hold the probes with fingers behind guards.
9. Avoid electrical shock. Use extreme caution when working near uninsulated conductors or bus bars. Prevent body contact with grounded surfaces such as pipes, radiators, ranges, and cabinet enclosures when testing voltages.
10. Observe work area conditions. Do not test voltages in damp or wet locations. Don't expose to rain. Keep work area clean and well lit.
11. Keep children away. Children must never be allowed in the work area.
12. Stay alert. Watch what you are doing, use common sense. Do not operate any meter when you are tired.
13. Do not operate meter if under the influence of alcohol or drugs. Read warning labels on prescriptions to determine if your judgment or reflexes are impaired while taking drugs. If there is any doubt, do not operate the meter.
14. People with pacemakers should consult their physician(s) before use. Electromagnetic fields in close proximity to heart pacemaker could cause pacemaker interference or pacemaker failure.
15. Do not test voltage on circuits higher than 250 volts AC or 20 volts DC.
16. Do not test current on circuits higher than 5A.
17. Dress properly. Protective, electrically nonconductive clothes and nonskid footwear are recommended when working.
18. Wear ANSI-approved safety goggles during use.
19. Only use accessories intended for use with this meter.
20. Avoid damaging meter. Use only as specified in this manual.
21. Prior to testing, resistance, diodes, or continuity; disconnect all power to the circuit and discharge all high-voltage capacitors.
22. Performance of this meter may vary depending on battery condition.
23. Use the proper settings, terminals, techniques, and range for the tests performed. Start with the range stated in the instructions.
24. Do not apply voltage to the Test Leads when the Multimeter is in the Ohms testing setting. Damage can occur to the multimeter.
25. Do not switch between testing modes with the multimeter connected to a circuit.
26. Do not use the meter at a setting marked as blank on the scale.
27. Have the multimeter calibrated by a qualified technician every year to maintain accurate results.
28. The warnings, cautions, and instructions discussed in this instruction manual cannot cover all possible conditions and situations that may occur. It must be understood by the operator that common sense and caution are factors which cannot be built into this product, but must be supplied by the operator.

29. Store idle equipment. When not in use, meters must be stored in a dry location to decrease exposure to moisture. Lock up meters and keep out of reach of children.



SAVE THESE INSTRUCTIONS.

Specifications

DC Voltage	Ranges: 200mV/2000mV/20V/200V/250V
DC Voltage Accuracy	(@200mV) 0.5%±1D; (@2000mV-250V) 1%±2D
AC Voltage	Ranges: 200/250V Frequency Range: 45-450Hz
AC Voltage Accuracy	(@200V) 1.2%±10D; (@250V) 1.2%±10D
DC Current	Ranges:200uA/2000uA/20mA/200mA/5A
DC Current Accuracy	(@0mA-200mA) 1.2%±2D; (@5A) 3%±2D
Resistance	Ranges: 200Ω/2KΩ/20KΩ/200KΩ/2000KΩ
Overload Protection	Fast-Acting 500mA and 5A Fuses
Battery	One 9V (included)

SAFETY

SETUP

OPERATION

MAINTENANCE

Setup - Before Use:



Read the **ENTIRE IMPORTANT SAFETY INFORMATION** section at the beginning of this manual including all text under subheadings therein before set up or use of this product.

Functions

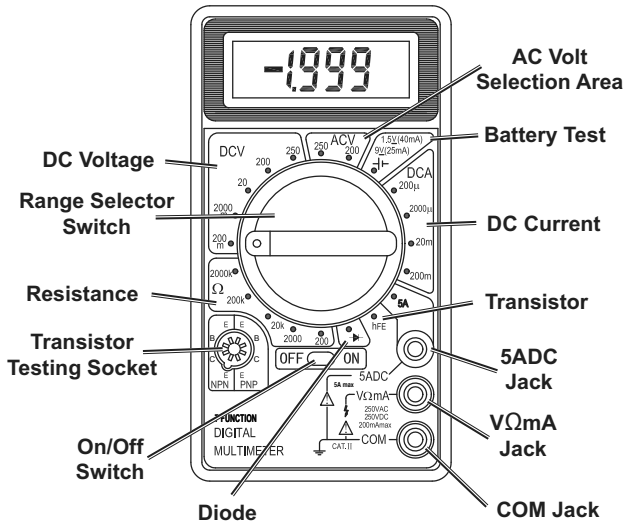

Operating Instructions



Read the **ENTIRE IMPORTANT SAFETY INFORMATION** section at the beginning of this manual including all text under subheadings therein before set up or use of this product.

Electrical shock can cause death or injury! NEVER TOUCH exposed conductors of electricity.

Measurement Operation

AC Voltage Measurement

Measure AC conductors carrying up to 250 VAC, 45-450 Hz.

WARNING! Use caution when working near voltages above 30 VAC rms or 42 VAC peak. Voltages this high present a risk of electric shock.

WARNING! To prevent damage to the Meter or personal serious injury, do not measure voltages higher than 250 VAC rms.

1. Turn the Range Selector Switch to 250 ACV setting. Start with the highest range if the voltage is unknown.
2. Plug the black lead into the **COM** Jack. Plug the red lead into the **VΩmA** Jack. Turn Multimeter ON.
3. Carefully touch the exposed conductors with the tips of the probes to measure the voltage (not amperes).
4. Read measurement. If the voltage is less than 200 volts, set the Range Selector Switch to the lower range.
5. When testing is complete, turn Multimeter OFF, remove Test Leads and store with Multimeter.

DC Voltage Measurement

Measure DC conductors carrying up to 250 VDC.

WARNING! Use caution when working near voltages above 60 VDC. Voltages this high present a risk of electric shock.

WARNING! To prevent damage to the Meter or personal serious injury, do not measure voltages higher than 250 VDC.

1. Turn the Range Selector Switch to 250 DCV setting.
2. Plug the black lead into the **COM** Jack. Plug the red lead into the **VΩmA** Jack. Turn Multimeter ON.
3. Carefully touch the exposed conductors with the tips of the probes to measure the voltage (not amperes).
4. Read measurement. If the voltage is less than the voltage of one of the lower ranges, set the Range Selector Switch to the range that is closest but still higher than the reading.
5. When testing is complete, turn Multimeter OFF, remove Test Leads and store with Multimeter.

DC Current Measurement

Measure current in DC circuits carrying up to 5 amperes.

Note: Amperage is always tested in series with circuit under test.

Note: When using manual range mode, always start with the highest range if the amperage is unknown.

WARNING! To prevent damage to the meter, be sure to use the correct input jacks.

1. Turn the Range Selector Switch to the 5A position. Start with the highest range if the amperage is unknown.
2. Always start with the highest range if the amperage is unknown.
3. Turn off power to the circuit and allow capacitors to discharge.
4. Break the circuit and connect the Test Leads in series with the circuit being measured. Connect the black lead on the lower voltage side.

- Plug black test lead into **COM** Jack.
- Plug red test lead into **5ADC** Jack.

5. Power on the circuit and read measurement. If the reading is less than 0.2 amps, switch the red lead to the **VΩmA** Jack and set the Range Selector Switch to the 200mA setting.
6. Repeat measurement. Set the Range Selector Switch to the range that is closest but still higher than the reading.

Note: Measure for a maximum 30 seconds and allow 15 minutes to pass between measurements.

7. When testing is complete, turn Multimeter OFF, remove Test Leads and store with Multimeter.

Resistance Measurement

Measure circuit resistance up to 2000K Ohms.

WARNING! To prevent electric shock, turn off all power and fully discharge capacitors in the circuit under test before measuring.

Notice: When measuring Ohms, start with the lowest range if the resistance is unknown.

1. Turn the Range Selector Switch to the 200Ω position.
2. Plug the black lead into the **COM** Jack. Plug the red lead into the **VΩmA** Jack. Turn Multimeter ON. Short the Test Leads together. The meter should read "0" Ohms.

3. Carefully touch the exposed conductors with the tips of the Probes.
4. Read measurement. If the reading is "1", set the Range Selector Switch to the next higher Ohm (Ω) position.
5. When testing is complete, turn Multimeter OFF, remove Test Leads and store with Multimeter.

Transistor (hFE) Measurement

Test transistors to ensure proper function.

1. Turn the Range Selector Switch to the hFE position. Turn Multimeter ON.
2. Insert transistor pins into the appropriate holes of the hFE testing socket (NPN or PNP) according to the EBC (Emitter, Base, Collector) sequence.
3. The meter will show the approximate hFE value.
4. When testing is complete, turn Multimeter OFF, remove and store Transistor and Multimeter.

Diode Measurement

Test the voltage drop in diodes.

WARNING! To prevent electric shock, turn off all power and fully discharge capacitors in the circuit under test before measuring.

1. Turn the Range Selector Switch to the Diode ($\rightarrow|+$) position.
2. Plug the black lead into the **COM** Jack. Plug the red lead into the **V Ω mA** Jack. Turn Multimeter ON.
3. Connect red probe to the anode of the diode and the black to the cathode.
4. The approximate forward voltage drop of the diode will be displayed in mV. If the connection is reversed, only "1" will be shown.
5. When testing is complete, turn Multimeter OFF, remove Test Leads and store with Multimeter.

Battery Test

Test the amount of charge left in batteries.

NOTE: This setting is for testing the charge of small **9V** or **1.5V** batteries only. Never use this setting to test automotive or lead-acid batteries. **The high current could cause damage to the meter and/or cause severe personal injury.** Use the appropriate DC Voltage setting to test the open circuit voltage of such batteries instead.

1. Turn the Range Selector Switch to the Battery (**⎓**) position.
2. Plug the black lead into the **COM** Jack. Plug the red lead into the **VΩmA** Jack. Switch the Multimeter ON.
3. Touch the red probe to the positive terminal of the battery and the black to the negative terminal.
4. The battery amperage through an internal 360 ohm resistor will be displayed to a resolution of .1mA.
5. Normal amperage: For a standard 9V (6LR61) battery the amperage will be approximately 25 mA (9V divided by 360 = 0.025). Weaker batteries will have a lower current.
6. Normal amperage: For a 1.5 V "AA" (LR6) battery the amperage will be approximately 4.2 mA (1.5V divided by 360 = 0.0042). Weaker batteries will have a lower current.
7. When testing is complete, turn Multimeter OFF, remove Test Leads and store with Multimeter.

Maintenance and Servicing



Procedures not specifically explained in this manual must be performed only by a qualified technician.

Cleaning, Maintenance, and Lubrication

1. Wipe unit with a dry, lint-free cloth. Do not use solvents or abrasives.
2. Remove battery if not in use for long periods.
3. Store unit in a dry location.
4. Other than the battery, there are no replaceable parts on this unit. **Repairs should be done by a qualified technician.**

Battery Replacement

If the  sign appears on the Display, the battery should be replaced.

1. Remove the Test Leads from the multimeter.
2. Turn the unit over.
3. Remove screws.
4. Remove back cover carefully.
5. Remove and replace with the same (9V battery).
6. Replace cover and replace screws.

Record Product's Serial Number Here: _____

Note: If product has no serial number, record month and year of purchase instead.

Note: Replacement parts may be available for this item. Visit harborfreight.com/parts for a list of in stock parts. Reference UPC 193175470928.

Limited 90 Day Warranty

Harbor Freight Tools Co. makes every effort to assure that its products meet high quality and durability standards, and warrants to the original purchaser that this product is free from defects in materials and workmanship for the period of 90 days from the date of purchase. This warranty does not apply to damage due directly or indirectly, to misuse, abuse, negligence or accidents, repairs or alterations outside our facilities, criminal activity, improper installation, normal wear and tear, or to lack of maintenance. We shall in no event be liable for death, injuries to persons or property, or for incidental, contingent, special or consequential damages arising from the use of our product. Some states do not allow the exclusion or limitation of incidental or consequential damages, so the above limitation of exclusion may not apply to you. THIS WARRANTY IS EXPRESSLY IN LIEU OF ALL OTHER WARRANTIES, EXPRESS OR IMPLIED, INCLUDING THE WARRANTIES OF MERCHANTABILITY AND FITNESS.

To take advantage of this warranty, the product or part must be returned to us with transportation charges prepaid. Proof of purchase date and an explanation of the complaint must accompany the merchandise. If our inspection verifies the defect, we will either repair or replace the product at our election or we may elect to refund the purchase price if we cannot readily and quickly provide you with a replacement. We will return repaired products at our expense, but if we determine there is no defect, or that the defect resulted from causes not within the scope of our warranty, then you must bear the cost of returning the product.

This warranty gives you specific legal rights and you may also have other rights which vary from state to state.