

Owner's Manual & Safety Instructions

Save This Manual Keep this manual for the safety warnings and precautions, assembly, operating, inspection, maintenance and cleaning procedures. Write the product's serial number in the back of the manual (or month and year of purchase if product has no number). Keep this manual and the receipt in a safe and dry place for future reference.

CENTRAL[®]

MACHINERY

BENCHTOP ABRASIVE BLAST CABINET



59477

Visit our website at: <http://www.harborfreight.com>
Email our technical support at: productsupport@harborfreight.com

When unpacking, make sure that the product is intact and undamaged. If any parts are missing or broken, please call 1-888-866-5797 as soon as possible.

Copyright© 2022 by Harbor Freight Tools®. All rights reserved.

No portion of this manual or any artwork contained herein may be reproduced in any shape or form without the express written consent of Harbor Freight Tools. Diagrams within this manual may not be drawn proportionally. Due to continuing improvements, actual product may differ slightly from the product described herein. Tools required for assembly and service may not be included.

⚠ WARNING





**Read this material before using this product.
Failure to do so can result in serious injury.
SAVE THIS MANUAL.**

Table of Contents

Safety	3	Maintenance	17
Specifications	9	Parts List and Diagram	20
Setup	10	Warranty	24
Operation.....	14		

CENTRAL[®] MACHINERY

WARNING SYMBOLS AND DEFINITIONS

	This is the safety alert symbol. It is used to alert you to potential personal injury hazards. Obey all safety messages that follow this symbol to avoid possible injury or death.
	Indicates a hazardous situation which, if not avoided, will result in death or serious injury.
	Indicates a hazardous situation which, if not avoided, could result in death or serious injury.
	Indicates a hazardous situation which, if not avoided, could result in minor or moderate injury.
	Addresses practices not related to personal injury.

SAFETY

SETUP

OPERATION

MAINTENANCE

IMPORTANT SAFETY INSTRUCTIONS

INSTRUCTIONS PERTAINING TO A RISK OF FIRE, ELECTRIC SHOCK, OR INJURY TO PERSONS

WARNING – When using tools, basic precautions should always be followed, including the following:



General

To reduce the risks of electric shock, fire, and injury to persons, read all the instructions before using the tool.

Work Area

1. **Keep the work area clean and well lighted.**
Cluttered benches and dark areas increase the risks of electric shock, fire, and injury to persons.
2. **Do not operate the tool in explosive atmospheres, such as in the presence of flammable liquids, gases, or dust.**
The tool is able to create sparks resulting in the ignition of the dust or fumes.
3. **Keep bystanders, children, and visitors away while operating the tool.** Distractions are able to result in the loss of control of the tool.

Personal Safety

1. **Stay alert. Watch what you are doing and use common sense when operating the tool. Do not use the tool while tired or under the influence of drugs, alcohol, or medication.**
A moment of inattention while operating the tool increases the risk of injury to persons.
2. **Dress properly. Do not wear loose clothing or jewelry. Contain long hair. Keep hair, clothing, and gloves away from moving parts.** Loose clothes, jewelry, or long hair increases the risk of injury to persons as a result of being caught in moving parts.
3. **Avoid unintentional starting. Be sure the switch is off before connecting to the air supply.**
Do not carry the tool with your finger on the switch or connect the tool to the air supply with the switch on.
4. **Do not overreach. Keep proper footing and balance at all times.**
Proper footing and balance enables better control of the tool in unexpected situations.
5.  **Use safety equipment.**
A dust mask, non-skid safety shoes and a hard hat must be used for the applicable conditions.
6.  **Always wear eye protection.**
Wear ANSI-approved safety goggles under blast hood.
7.  **Always wear hearing protection when using the tool.**
Prolonged exposure to high intensity noise is able to cause hearing loss.
8. **Risk of Electric Shock. This tool is not provided with an insulated gripping surface.**
Contact with a "live" wire will also make exposed metal parts of the tool "live" and shock the operator.
9. **Avoid body contact with grounded surfaces such as pipes, radiators, ranges and refrigerators.** There is an increased risk of electric shock if your body is grounded.
10. **Explore the workpiece to avoid contact with hidden wiring.** Thoroughly investigate the workpiece for possible hidden wiring before performing work. Contact with live wiring will shock the operator.
11. **Wear heavy-duty blast gloves during use.**

Tool Use and Care

SAFETY

1. **Use clamps or another practical way to secure and support the workpiece to a stable platform.** Holding the work by hand or against the body is unstable and is able to lead to loss of control.
2. **Do not force the tool.** Use the correct tool for the application. The correct tool will do the job better and safer at the rate for which the tool is designed.
3. **Do not use the tool if the Trigger does not turn the tool on or off.** Any tool that cannot be controlled with the trigger is dangerous and must be repaired.
4. **Disconnect the tool from the air source before making any adjustments, changing accessories, or storing the tool.** Such preventive safety measures reduce the risk of starting the tool unintentionally. Turn off and detach the air supply, safely discharge any residual air pressure, and release the throttle and/or turn the switch to its off position before leaving the work area.
5. **Store the tool when it is idle out of reach of children and other untrained persons.** A tool is dangerous in the hands of untrained users.
6. **Maintain the tool with care.** Keep a cutting tool sharp and clean. A properly maintained tool, with sharp cutting edges reduces the risk of binding and is easier to control.
7. **Check for misalignment or binding of moving parts, breakage of parts, and any other condition that affects the tool's operation.** If damaged, have the tool serviced before using. Many accidents are caused by poorly maintained tools. There is a risk of bursting if the tool is damaged.
8. **Use only accessories that are identified by the manufacturer for the specific tool model.** Use of an accessory not intended for use with the specific tool model, increases the risk of injury to persons.

SETUP

OPERATION

MAINTENANCE

CENTRAL[®]
MACHINERY

Service

1. *Tool service must be performed only by qualified repair personnel.*
2. **When servicing a tool, use only identical replacement parts. Use only authorized parts.**

Air Source

1.  **Never connect to an air source that is capable of exceeding 200 psi.** Over pressurizing the tool may cause bursting, abnormal operation, breakage of the tool or serious injury to persons. Use only clean, dry, regulated compressed air at the rated pressure or within the rated pressure range as marked on the tool. Always verify prior to using the tool that the air source has been adjusted to the rated air pressure or within the rated air-pressure range.
2. **Never use oxygen, carbon dioxide, combustible gases or any bottled gas as an air source for the tool.** Such gases are capable of explosion and serious injury to persons.



SAVE THESE INSTRUCTIONS.

CENTRAL[®]
MACHINERY

Specific Safety Instructions

SAFETY

1. The warnings and precautions discussed in this manual cannot cover all possible conditions and situations that may occur. It must be understood by the operator that common sense and caution are factors which cannot be built into this product, but must be supplied by the operator.
2. **Avoid working alone.** If an accident happens, an assistant can bring help.
3. **Maintain labels and nameplates on the Blast Cabinet.** These carry important information. If unreadable or missing, contact Harbor Freight Tools for a replacement.
4. **Maintain a firm grip on the Blast Gun when in use.**
5. **Never point the Blast Gun toward yourself, other people, or animals.** Keep all people and animals safely away from the work area.
6. **Industrial applications must follow OSHA requirements.**
7. **Whenever possible, perform an abrasive blasting test on a small area of the object to be blasted.** If necessary, adjust the distance to the object and/or change the Nozzle of the Blast Gun for more effective results.
8. **Read and understand all safety warnings and precautions as outlined in the manufacturer's manual for the object you intend to blast with abrasives.**
9. Obey the manual for the air compressor used to power this tool.
10. Install an in-line shutoff valve to allow immediate control over the air supply in an emergency, even if a hose is ruptured.

SETUP

Silicosis Safety Measures

DO NOT USE SAND!

Abrasive blasting with sand (which contains crystalline silica) can cause silicosis (a serious lung disease), cancer and death. To reduce crystalline silica exposures in the workplace and prevent silicosis and silicosis-related deaths:

1. Prohibit silica sand (or other substances containing more than 1% crystalline silica) as an abrasive blasting material and substitute less hazardous materials.
2. Conduct air monitoring to measure worker exposures.
3. Use containment methods such as blast-cleaning machines and cabinets to control the hazard and protect adjacent workers from exposure.
4. Practice good personal hygiene to avoid unnecessary exposure to silica dust.
5. Wear washable or disposable protective clothes at the work site. Shower and change into clean clothes before leaving the work site to prevent contamination of cars, homes and other work areas. Avoid skin exposure.
6. Always wear a NIOSH approved respirator and safety goggles. Ventilate the work area properly.
7. Provide periodic medical examinations for all workers who may be exposed to crystalline silica.
8. Post signs to warn workers about the hazard and to inform them about required protective equipment.
9. Provide workers with training that includes information about health effects, work practices and protective equipment for crystalline silica.
10. Report all cases of silicosis to State health departments and to OSHA or the Mine Safety and Health Administration (MSHA).

OPERATION

MAINTENANCE

Vibration Precautions

This tool vibrates during use. Repeated or long-term exposure to vibration may cause temporary or permanent physical injury, particularly to the hands, arms and shoulders. To reduce the risk of vibration-related injury:

1. Anyone using vibrating tools regularly or for an extended period should first be examined by a doctor and then have regular medical check-ups to ensure medical problems are not being caused or worsened from use. Pregnant women or people who have impaired blood circulation to the hand, past hand injuries, nervous system disorders, diabetes, or Raynaud's Disease should not use this tool. If you feel any symptoms related to vibration (such as tingling, numbness, and white or blue fingers), seek medical advice as soon as possible.
2. Do not smoke during use. Nicotine reduces the blood supply to the hands and fingers, increasing the risk of vibration-related injury.
3. Wear suitable gloves to reduce the vibration effects on the user.
4. Use tools with the lowest vibration when there is a choice.
5. Include vibration-free periods each day of work.
6. Grip tool as lightly as possible (while still keeping safe control of it). Let the tool do the work.
7. To reduce vibration, maintain tool as explained in this manual. If abnormal vibration occurs, stop immediately.



SAVE THESE INSTRUCTIONS.

CENTRAL[®]
MACHINERY



Symbols and Specific Safety Instructions

Symbol Definitions

SAFETY

Symbol	Property or statement
PSI	Pounds per square inch of pressure
CFM	Cubic Feet per Minute flow
SCFM	Cubic Feet per Minute flow at standard conditions
NPT	National pipe thread, tapered
NPS	National pipe thread, straight
	WARNING marking concerning Risk of Eye Injury. Wear ANSI-approved eye protection.

SETUP

Symbol	Property or statement
	WARNING marking concerning Risk of Hearing Loss. Wear hearing protection.
	WARNING marking concerning Risk of Respiratory Injury. Wear NIOSH-approved dust mask/respirator.
	WARNING marking concerning Risk of Explosion.

OPERATION

MAINTENANCE

CENTRAL[®]
MACHINERY

Specifications

Compressor Requirements	5 HP or larger compressor
Maximum Air Pressure	100 PSI
Air Inlet	1/4" NPT
Nozzle Type	Ceramic - .18", .19", .22", .27"
Average Air Consumption	11 CFM @ 90 PSI
Operating Air Pressure	Up to 100 PSI
Hopper Capacity	30 lb

Components and Controls

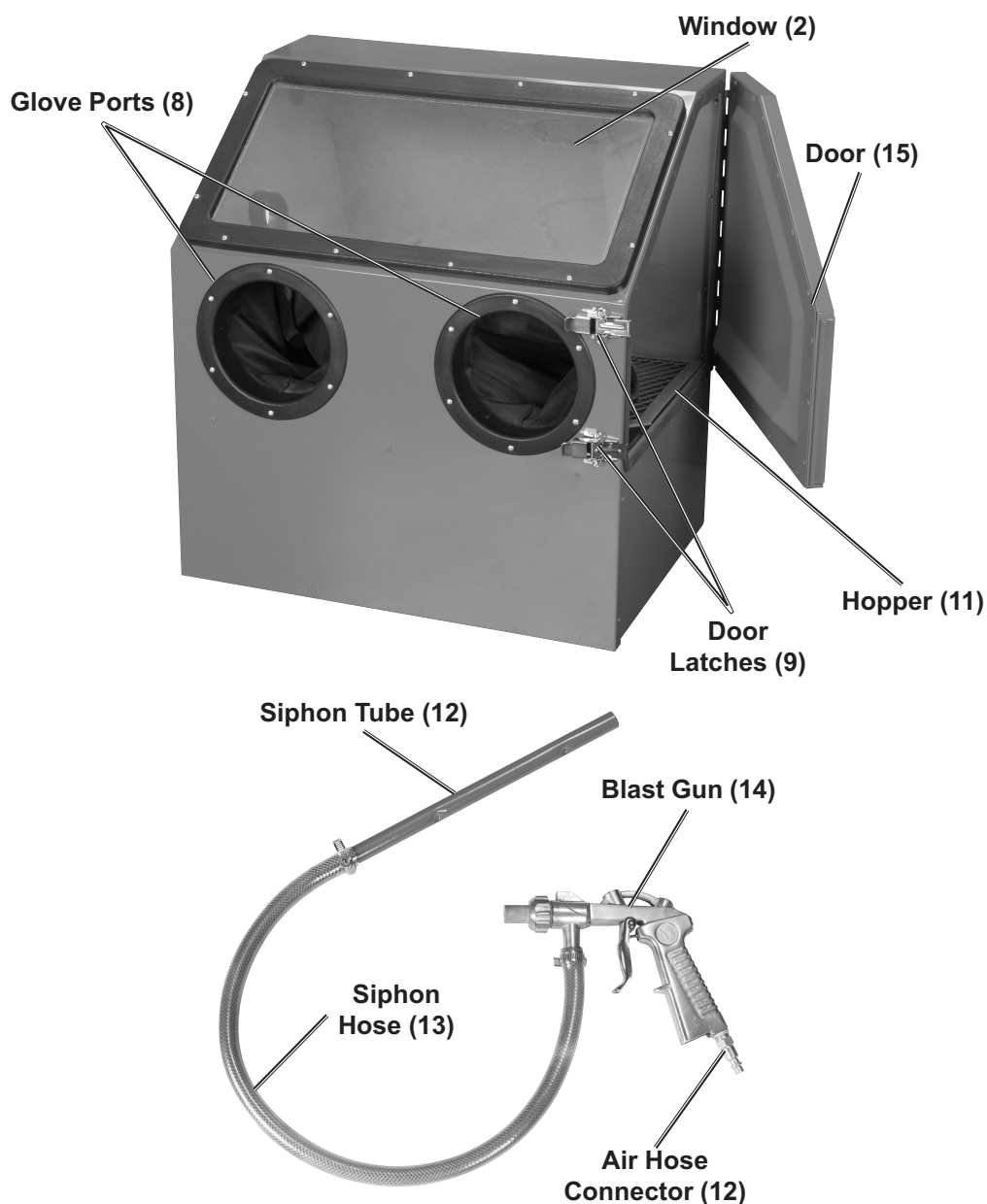

Initial Tool Set Up/Assembly



Read the **ENTIRE IMPORTANT SAFETY INFORMATION** section at the beginning of this manual including all text under subheadings therein before set up or use of this product.

Note: For additional information regarding the parts listed in the following pages, refer to the Assembly Diagram near the end of this manual.

Note: This air tool may be shipped with a protective plug covering the air inlet. Remove this plug before set up.

Verify all hose clamps and fittings are tightened on the Siphon Hose, Siphon Tube, and air supply hose to the gun.

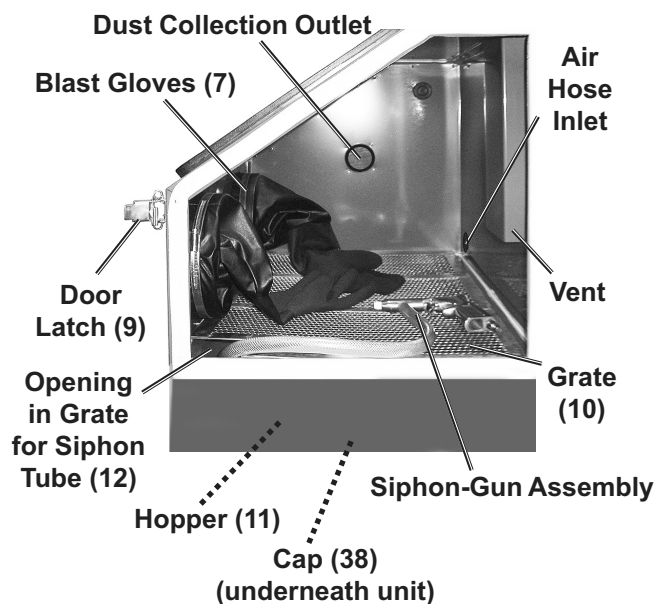

Air Supply

⚠ WARNING



TO PREVENT SERIOUS INJURY FROM EXPLOSION:

Use only clean, dry, regulated, compressed air to power this tool.

Do not use oxygen, carbon dioxide, combustible gases, or any other bottled gas as a power source for this tool.

1. Incorporate a filter, regulator with pressure gauge, dryer, in-line shutoff valve, and quick coupler for best service, as shown on Figure A on page 12 and Figure B on page 13. **An in-line shutoff ball valve is an important safety device because it controls the air supply even if the air hose is ruptured. The shutoff valve should be a ball valve because it can be closed quickly.**

Note: Do not use an oiler system with this tool. The oil will mix with the material being propelled, causing poor results.

2. Attach an air hose to the compressor's air outlet. Connect the air hose to the air inlet of the tool. Other components, such as a coupler plug and quick coupler, will make operation more efficient, but are not required.

⚠ WARNING! TO PREVENT SERIOUS INJURY FROM ACCIDENTAL OPERATION:

Do not install a female quick coupler on the tool.

Such a coupler contains an air valve that will allow the air tool to retain pressure and operate accidentally after the air supply is disconnected.

Note: Air flow, and therefore tool performance, can be hindered by undersized air supply components. The air hose must be long enough to reach the work area with enough extra length to allow free movement while working.

3. Turn the tool's throttle or switch to the off position; refer to Operation section for description of controls.
4. Close the in-line shutoff valve between the compressor and the tool.
5. Turn on the air compressor according to the manufacturer's directions and allow it to build up pressure until it cycles off.
6. Adjust the air compressor's output regulator so that the air output is enough to properly power the tool, but the output will not exceed the tool's maximum air pressure at any time. Adjust the pressure gradually, while checking the air output gauge to set the right pressure range.

Note: For best results, use high-flow fittings. Minimize number of fittings and air hose length.

7. Inspect the air connections for leaks. Repair any leaks found.
8. If the tool will not be used at this time, turn off and detach the air supply, safely discharge any residual air pressure, and release the throttle and/or turn the switch to its off position to prevent accidental operation.
9. Residual air pressure should not be present after the tool is disconnected from the air supply. However, it is a good safety measure to attempt to discharge the tool in a safe fashion after disconnecting to ensure that the tool is disconnected and not powered.
10. This item requires 11 CFM at 90 PSI. Follow runtime chart. Do not use for extended periods to avoid excess wear of compressor pump.

USAGE TIMES PER COMPRESSOR			
COMPRESSOR SIZE (Gallons)	COMPRESSOR RATING (PSI) (SCFM)		Estimated Run Time at 90PSI (Seconds)
3	110	0.6	Not Recommended
10	175	4.3	45
20	135	4.0	30
27	200	5.1	170
80	175	15.6	Continuous
<ul style="list-style-type: none"> • Table accounts for compressor pump running while using tool. • Operating the tool at lower pressures will extend run time, but may reduce performance. • Compressors with increased pressure, flow or tank size will increase run time. • Improperly sized fittings and hoses may reduce air pressure and run time. 			



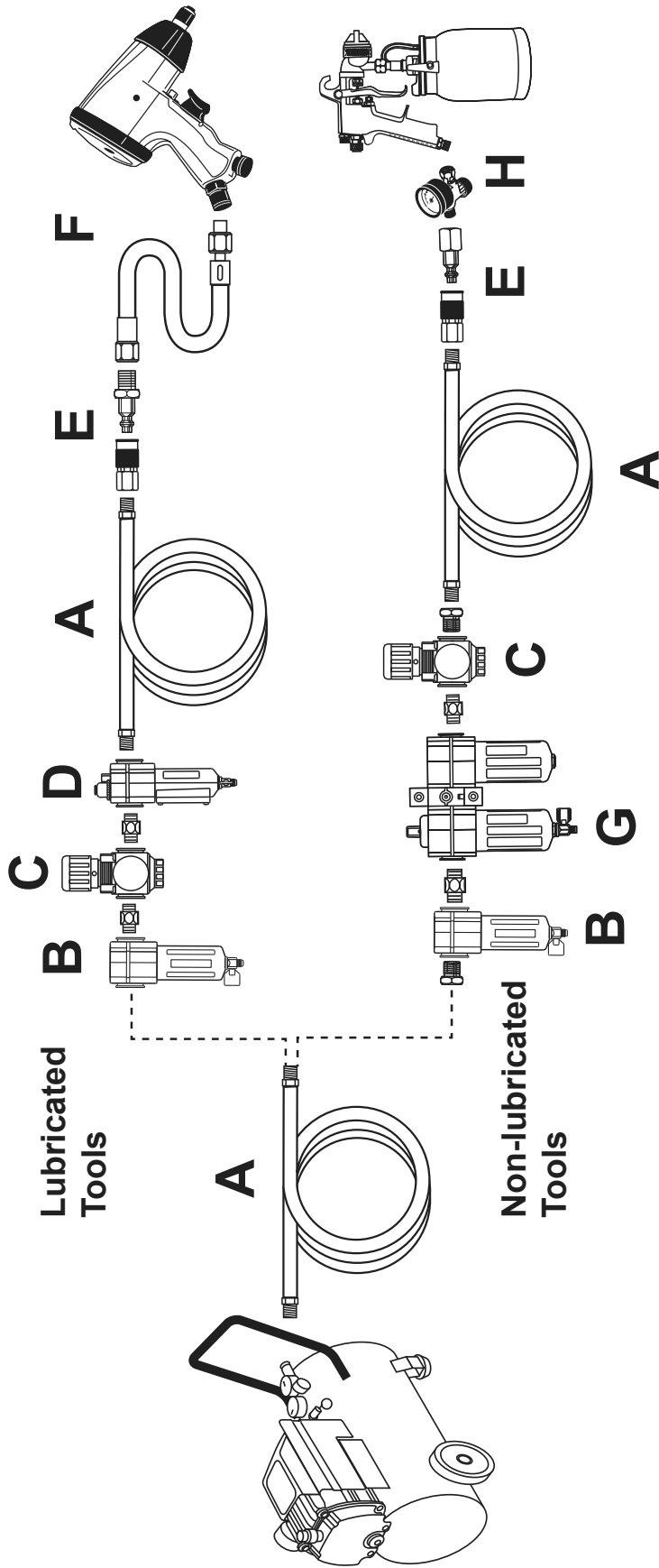
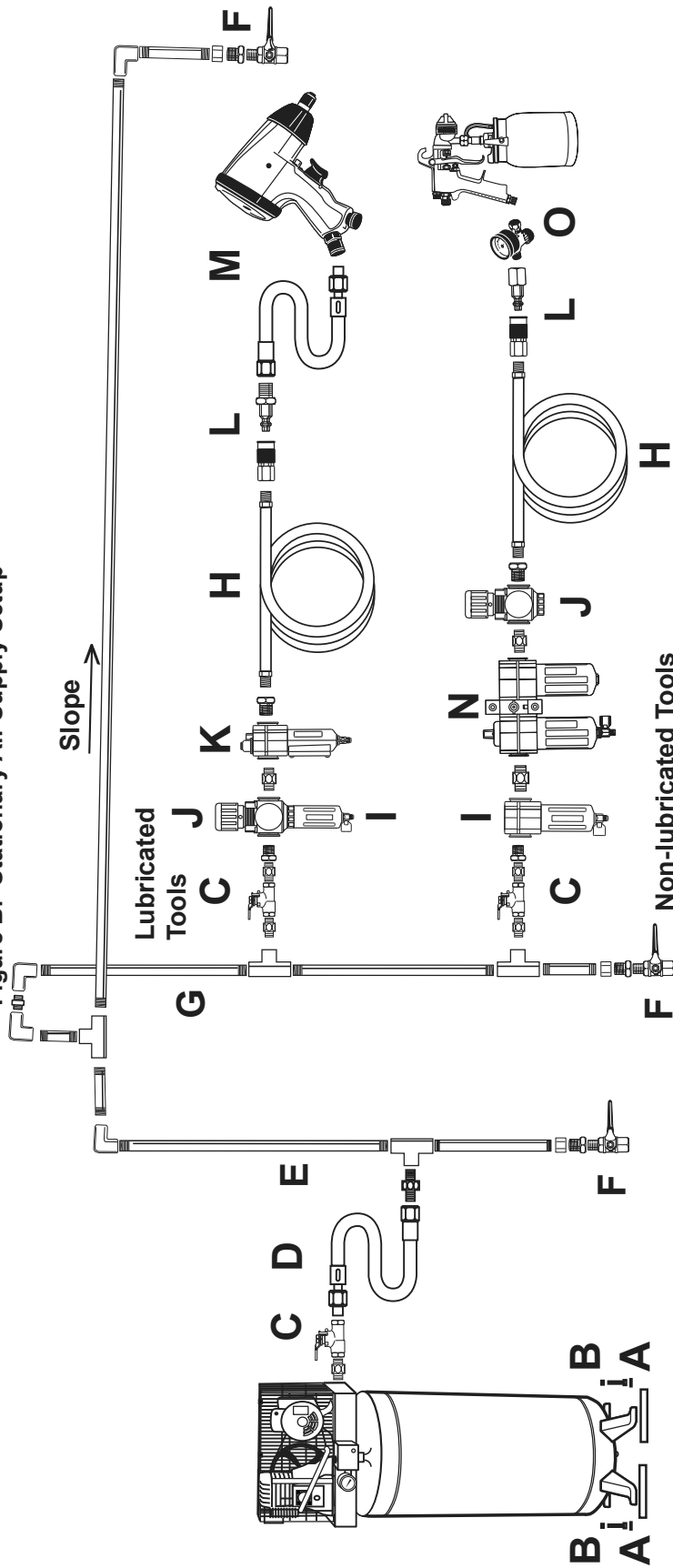

Figure A: Portable Air Supply Setup

Description	Function
A Air Hose	Connects air to tool
B Filter	Prevents dirt and condensation from damaging tool or workpiece
C Regulator	Adjusts air pressure to tool
D Lubricator (optional)	For air tool lubrication
E Coupler and Plug	Provides quick connection and release
F Leader Hose (optional)	Increases coupler life
G Air Cleaner / Dryer (optional)	Prevents water vapor from damaging workpiece
H Air Adjusting Valve (optional)	For fine tuning airflow at tool

Figure B: Stationary Air Supply Setup



	Description	Function
A	Vibration Pads	For noise and vibration reduction
B	Anchor Bolts	Secures air compressor in place
C	Ball Valve	Isolates sections of system for maintenance
D	Isolation Hose	For vibration reduction
E	Main Air Line - 3/4" minimum recommended	Distributes air to branch lines
F	Ball Valve	To drain moisture from system
G	Branch Air Line - 1/2" minimum recommended	Brings air to point of use
H	Air Hose	Connects air to tool
I	Filter	Prevents dirt and condensation from damaging tool or workpiece
J	Regulator	Adjusts air pressure to tool
K	Lubricator (optional)	For air tool lubrication
L	Coupler and Plug	Provides quick connection and release
M	Leader Hose (optional)	Increases coupler life
N	Air Cleaner / Dryer (optional)	Prevents water vapor from damaging workpiece
O	Air Adjusting Valve (optional)	For fine tuning airflow at tool

Operating Instructions



Read the **ENTIRE IMPORTANT SAFETY INFORMATION** section at the beginning of this manual including all text under subheadings therein before set up or use of this product.

Inspect tool before use, looking for damaged, loose, and missing parts.
If any problems are found, do not use tool until repaired.

Tool Set Up

WARNING

TO PREVENT SERIOUS INJURY FROM ACCIDENTAL OPERATION:

Turn off the tool, detach the air supply, safely discharge any residual air pressure in the tool, and release the throttle and/or turn the switch to its off position before performing any inspection, maintenance, or cleaning procedures.

TO PREVENT SERIOUS INJURY:

Do not adjust or tamper with any control or component in a way not specifically explained within this manual. Improper adjustment can result in tool failure or other serious hazards.

1. **Wear protective gear including a NIOSH-approved respirator.**
2. Close the Air Supply Valve, Abrasive Valve, then the Throttle Valve.
3. Pull the ring on the Safety Valve out to make sure its Tank is not pressurized, then release it. Check the Air Pressure Gauge to make sure it reads "0" PSI.
6. Insert the Siphon Tube through the corner opening of the Grate (10) so that it is resting in the Hopper (11).
7. It is recommended that you set up a vacuum dust collector (sold separately) to remove media dust while blasting. Remove cover on left side of Cabinet and attach the vacuum hose through the Dust Collection Outlet.

WARNING! TO PREVENT SERIOUS INJURY: Do not use sand or other blasting materials that contain crystalline silica.

CAUTION! Exposure to aluminum oxide (an abrasive media) can result in eye, skin and breathing irritation.

Note: Use only dry and clean abrasives to avoid clogging the Blaster.

Note: Change the Nozzle as needed to suit the abrasive grit. Refer to Nozzle Replacement on page 18. The included nozzles are not designed for use with steel shot.

4. To install or change the Nozzle, loosen the Nozzle Lock (1A). Slide the desired Nozzle in place and tighten the Nozzle Lock.

Note: By changing to the next larger size of Nozzle, production can increase significantly. Larger size Nozzles produce a larger cleaning pattern. This also requires a higher air pressure and greater air flow.

5. Slide one end of the Siphon Hose (13) onto the Siphon Tube (12) and the other end onto the Blast Gun (14).

When using a vacuum dust collector, clean the filter periodically to maintain good suction and effectiveness of the vacuum. Use the appropriate vacuum for the job.

Note: If dust collector is not used, the round cover must be in place on side of Cabinet.

8. Open the Cabinet door and fill the Hopper with approximately 5 pounds of an appropriate abrasive, such as glass beads or walnut shells, checking to ensure that the abrasives are dry and clean. Do not use harsh abrasives such as steel shot or aluminum oxide. Do not overload the hopper with media as it can inhibit media flow to the gun.
9. Set the compressor's pressure regulator to 90 PSI. Do not set it over 100 PSI.
10. Route the compressor hose from the outside of the Cabinet to the inside through the Air Hose Inlet in the back of the Cabinet, then connect it to the Air Hose Connector (12A) on the Blast Gun inside the Cabinet.
11. Holding the Blast Gun so that it is pointing away from you, open the shut-off valve. If leaking is detected, disconnect the air hose and repair before use.

Workpiece and Work Area Set Up

1. Designate a work area that is clean and well-lit. The work area must not allow access by children or pets to prevent distraction and injury.
2. Route the air hose along a safe route to reach the work area without creating a tripping hazard or exposing the hose to possible damage. The hose must be long enough to reach the work area with enough extra length to allow free movement while working.
3. Place the Blast Cabinet on a sturdy level work surface, positioning the Cabinet at a level so that you can comfortably access the Glove openings and easily see into the Blast Cabinet through the Window. The work surface needs to be able to support the weight of the Blast Cabinet and the abrasive which will fill the Hopper, the work piece and any additional material required to be close at hand.
4. Secure loose workpieces using a vise or clamps (not included) to prevent movement while working.
5. There must not be hazardous objects (such as utility lines or foreign objects) nearby that will present a hazard while working.

CENTRAL[®]
MACHINERY

General Operating Instructions

SAFETY

WARNING! TO PREVENT SERIOUS INJURY: Wear ANSI-approved safety goggles and NIOSH-approved respirator under Blast Hood, and heavy-duty blast gloves, when operating the Blaster.

1. To protect the compressor and its engine or motor from damage by abrasive or dust from abrasive blasting, keep the compressor upwind of the Blaster or in a separate room.
2. **Close the Air Supply Valve, Abrasive Valve, and Throttle Valve, then connect and turn on the air supply.**
3. Place the workpiece to be blasted on the Grate inside the Blast Cabinet.
4. If needed, turn on LED lamp.
5. Close the Door (15) and hook the Door Latch (9) over the door flange and lock in place. Check to make sure the Latch is secured.
6. Place your hands into the Blast Gloves (7), making sure your fingers are in the proper positions and that you can easily move your hands and grip objects.

NOTICE: Do not attempt to regulate the air/blast media mixture discharge rate with the Trigger Valve. Doing so will ruin it.

7. Grip the gun with one hand. Point the nozzle at the bottom of the Cabinet and operate the Gun for a moment to ensure everything is working correctly. If leaking is detected, or blasting material dust is escaping the side door seals, disconnect the air hose and have it repaired before using.
8. Hold the object you are working with in your other hand. Position your fingers so the Blast Glove is not in the way of the area you are blasting. You may have to re-position your fingers many times during the blasting to ensure that you reach every area of your object.
9. Squeeze the Trigger on the Blast Gun to begin operation. Release the Trigger to stop.

Aim the nozzle directly at the surface of the workpiece. Bring the nozzle to within 2 inches of the workpiece if necessary. Move the Gun in a side-to-side or circular motion, always making sure that your fingers are not in the way.

Use even passes of the Gun to remove rust, body filler, or other soft materials.

SETUP

OPERATION

MAINTENANCE

10. To check on the progress of your blasting, remove your hand from the gun first and pull your hand from the Glove. Remove your other hand. Turn off compressor and dust collection system (if equipped). Wait for the air inside the cabinet to clear. Once the gun is off, open the door and inspect the workpiece. If additional blasting is required, follow steps 1 through 8 as needed.

Note: Use caution when sandblasting unfamiliar material. Test the tool on a small area before proceeding. This will ensure you will not damage or pit the material you wish to sandblast.

Note: The flow rate of the abrasive may be irregular when the unit is first started. If the abrasive is dry, the flow rate will stabilize in approximately one minute.

11. If the tool requires more force to accomplish the task, verify that the tool receives sufficient, unobstructed airflow (CFM) and increase the pressure (PSI) output of the regulator up to the maximum air pressure rating of this tool.

CAUTION! TO PREVENT INJURY FROM TOOL OR ACCESSORY FAILURE:

Do not exceed the tool's maximum air pressure rating.

If the tool still does not have sufficient force at maximum pressure and sufficient airflow, then a larger tool may be required.

12. Once completed, remove your hands from the Gloves and shut off the compressor. Open the Door and remove the workpiece from the Blast Cabinet.
13. To prevent accidents, turn off the tool, detach the air supply, safely discharge any residual air pressure in the tool, and release the throttle and/or turn the switch to its off position after use. Clean external surfaces of the tool with clean, dry cloth. Then store the tool indoors out of children's reach.

User-Maintenance Instructions



Procedures not specifically explained in this manual must be performed only by a qualified technician.

!WARNING

TO PREVENT SERIOUS INJURY FROM ACCIDENTAL OPERATION:

Turn off the tool, detach the air supply, safely discharge any residual air pressure in the tool, and release the throttle and/or turn the switch to its off position before performing any inspection, maintenance, or cleaning procedures.

TO PREVENT SERIOUS INJURY FROM TOOL FAILURE:

Do not use damaged equipment. If abnormal noise, vibration, or leaking air occurs, have the problem corrected before further use.

Cleaning, Maintenance, and Lubrication

Note: These procedures are in addition to the regular checks and maintenance explained as part of the regular operation of the air-operated tool.

1. **BEFORE EACH USE**, inspect the general condition of the tool. Check for:

- loose hardware or housing,
- misalignment or binding of moving parts,
- cracked or broken parts, and
- any other condition that may affect its safe operation.

2. **Daily - Air Supply Maintenance:**

Every day, maintain the air supply according to the component manufacturers' instructions. Drain the moisture filter regularly. Performing routine air supply maintenance will allow the tool to operate more safely and will also reduce wear on the tool.

3. **Quarterly (every 3 months) –**

Tool Disassembly, Cleaning, and Inspection:

Have the internal mechanism cleaned, inspected, and lubricated by a qualified technician.

- a. Disconnect the dust collection system from the Blast Cabinet.
- b. Disconnect Air Hose and Syphon Hoses from the Gun.

Cleaning the Hopper

It is not necessary to remove the blasting medium from the Hopper after every use. However, clean out the Hopper when a different blasting medium is to be used or when the medium gets worn down. To clean the Hopper:

WARNING: Wear ANSI-approved safety goggles, full face shield and a NIOSH-approved protective dust mask or respirator when replacing the abrasive medium in the Blast Cabinet.

1. Remove the Gun from the Cabinet.
2. Pull the Gloves through the glove holes so that they are out of the way of the inside of the Blast Cabinet.
3. Remove the Grate from the Blast Cabinet.
4. Straddle the Blast Cabinet over two saw horses (sold separately) with an open container below which is large enough to hold the abrasive material in the hopper.
5. Unthread the Cap (38) at the bottom of the Hopper and allow the abrasive medium to flow into the container.
6. Use your compressor set at 10 PSI to help blow any excess abrasive out of the hopper and into the container. Also, use the compressor to clean abrasive out of the Blast Gun and the Syphon Hose and Syphon Tube.
7. Replace the Cap and the Grate once the Hopper is empty.
8. Push the Gloves back into the Blast Cabinet.
9. Reassemble the Syphon Hose, Syphon Tube and Blast Gun and fill the Hopper with new blasting medium.

Blast Gun Maintenance

After every use, clean out the Blast Gun. To clean the gun:

1. Remove the Siphon Hose from the Blast Gun.
2. Operate the Gun for a few seconds to clear the passages.
3. Turn off the shut-off valve.
4. Disconnect the air compressor.
5. Discharge any residual air from the line and the Gun.
6. When re-using abrasive, sharp edges of abrasive particles eventually become rounded and lose cutting ability. At this point, replace the abrasive.
7. The parts of the tool that require frequent wear inspection and occasional replacement are those that carry the air/abrasive mixture. Pay particular attention to the Abrasive Hose, O-Rings, Abrasive Valve, and Blast Gun components (Trigger Valve, Nozzle), as they will wear out much more quickly than the other pieces.

Sandblasting is a damaging operation. In time, the internal parts of the Blast Gun will become worn. When performance of the Blast Gun decreases, take it to a qualified service technician for repair.

CAUTION! Air leaks in any of the above mentioned parts need to be repaired before use.

Abrasive Hose inspection:

When new, the Abrasive Hose has 1/2" ID. The Abrasive Hose will need to be replaced when its side wall develops leaks or shows blisters on the surface.

WARNING! TO PREVENT SERIOUS INJURY: The Abrasive Hose could have residual abrasive or suddenly burst. Point the Blast Gun in a safe direction and wear all safety gear when doing this test.

1. **Close the Air Supply Valve, Abrasive Valve, and Throttle Valve, then release the Trigger Valve. Then connect and turn on the air supply.**
2. Adjust the air pressure to 60-125 PSI.
3. Open the Air Supply Valve.
4. Open the Throttle Valve.
5. Then, run your fingers along the length of the Abrasive Hose. An enlarged spot (or bubble) indicates a weakened section of the Abrasive Hose. **Do not use the Blaster if this problem is present - replace the entire Abrasive Hose first.**

Nozzle Replacement

To change Blast Gun Nozzle size to suit the blast media being used or to replace a worn Nozzle, use the following procedure:

1. Unscrew and remove the Nozzle Cap Nut.
2. Remove the old Nozzle.
3. Position the Nozzle Gasket against the Adapter.
4. Position the replacement Nozzle against the Nozzle Gasket.
5. Screw the Nozzle Cap Nut back onto the Adapter to secure the Nozzle Gasket and Nozzle in place.

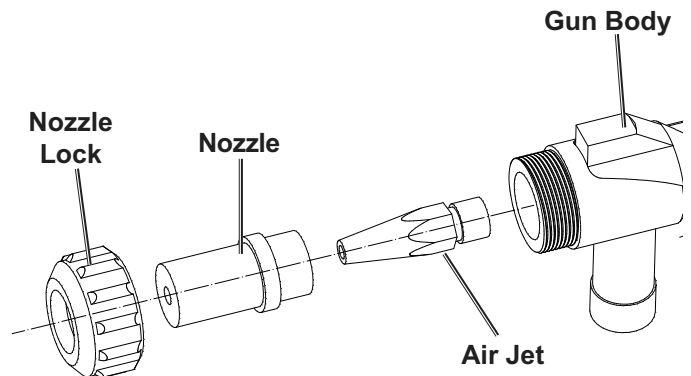

Troubleshooting

1. Excess moisture will cause the blast media to slow or stop flowing through the Abrasive Outlet Manifolds. To correct, check the blast media by pouring a 6" cone of blast media on dry newspaper. After several minutes, remove the blast media from the newspaper. Do not use the blast media if the newspaper is moist.
2. Poor or irregular flow of the blast media may also be due to low air pressure or a worn Blast Gun Nozzle. To correct, increase the air pressure (to no more than 125 PSI) and/or replace the worn Nozzle.

Problem	Possible Causes	Likely Solutions
Decreased output.	<ol style="list-style-type: none"> 1. Not enough air pressure and/or air flow. 2. Obstructed trigger. 3. Blocked air inlet screen (if equipped). 4. Air leaking from loose housing. 5. Mechanism contaminated. 	<ol style="list-style-type: none"> 1. Check for loose connections and make sure that air supply is providing enough air flow (CFM) at required pressure (PSI) to the tool's air inlet. Do not exceed maximum air pressure. 2. Clean around trigger to ensure free movement. 3. Clean air inlet screen of buildup. 4. Make sure housing is properly assembled and tight. 5. Have qualified technician clean and lubricate mechanism. Install in-line filter in air supply as stated in Setup: Air Supply.
Severe air leakage. (Slight air leakage is normal, especially on older tools.)	<ol style="list-style-type: none"> 1. Cross-threaded housing components. 2. Loose housing. 3. Damaged valve or housing. 4. Dirty, worn or damaged valve. 	<ol style="list-style-type: none"> 1. Check for incorrect alignment and uneven gaps. If cross-threaded, disassemble and replace damaged parts before use. 2. Tighten housing assembly. If housing cannot tighten properly, internal parts may be misaligned. Technician needs to disassemble tool, align parts and reassemble. 3. Replace damaged components. 4. Clean or replace valve assembly.
Housing heats during use.	Worn parts.	Have qualified technician inspect internal mechanism and replace parts as needed.



**Follow all safety precautions whenever diagnosing or servicing the tool.
Disconnect air supply before service.**

PLEASE READ THE FOLLOWING CAREFULLY

THE MANUFACTURER AND/OR DISTRIBUTOR HAS PROVIDED THE PARTS LIST AND ASSEMBLY DIAGRAM IN THIS MANUAL AS A REFERENCE TOOL ONLY. NEITHER THE MANUFACTURER OR DISTRIBUTOR MAKES ANY REPRESENTATION OR WARRANTY OF ANY KIND TO THE BUYER THAT HE OR SHE IS QUALIFIED TO MAKE ANY REPAIRS TO THE PRODUCT, OR THAT HE OR SHE IS QUALIFIED TO REPLACE ANY PARTS OF THE PRODUCT. IN FACT, THE MANUFACTURER AND/OR DISTRIBUTOR EXPRESSLY STATES THAT ALL REPAIRS AND PARTS REPLACEMENTS SHOULD BE UNDERTAKEN BY CERTIFIED AND LICENSED TECHNICIANS, AND NOT BY THE BUYER. THE BUYER ASSUMES ALL RISK AND LIABILITY ARISING OUT OF HIS OR HER REPAIRS TO THE ORIGINAL PRODUCT OR REPLACEMENT PARTS THERETO, OR ARISING OUT OF HIS OR HER INSTALLATION OF REPLACEMENT PARTS THERETO.

Parts List - Blast Cabinet

Part	Description	Qty
1	Window Frame	1
2	Window	1
3	Window Liner	3
4	Body	1
5	Port Washer	2
6	Glove Port	2
7	Blast Glove	2
8	Glove Clamp	2
9	Door Latch	2
10	Grate	1
11	Siphon Tube	1
12	Siphon Hose	1
13	Blast Gun	1
14	Door	1
15	Sealing Strip	1
16	Door Edge Trim	1
17	Hinge	1
18	Rubber Ring	1
19	LED Lamp	1
20	Lamp Lock	2

Part	Description	Qty
21	Transformer	1
22	Switch Box	1
23	Flange	1
24	Door Edgings	1
25	Window Frame, M5 x 25 Screw & Nut	12
26	Flange, M5 x 10 Screw & Nut	4
27	Switch Box, M5 x 8 Screw & Nut	2
28	Siphon Tube, M6 x 12 Screw & Nut	2
29	Lamp Lock, M6 x 6 Screw & Nut	2
30	Hopper Cover	1
31	Lamp Line	1
32	4.5/5/6/7mm Ceramic Nozzle	4
33	Air Hose	1
34	Teflon Tape	1
35	Thread Connector	2
36	Rubber Flat Gasket	1
37	Internal Thread Connector	1
38	Clamp Φ16-25	2
39	Clamp Φ8-12	2
40	Silicone Sealant	1

Record Product's Serial Number Here: _____

Note: If product has no serial number, record month and year of purchase instead.

Note: Some parts are listed and shown for illustration purposes only, and are not available individually as replacement parts. Specify UPC 193175471888 when ordering parts.

SAFETY

SETUP

OPERATION

MAINTENANCE

Assembly Diagram - Blast Cabinet

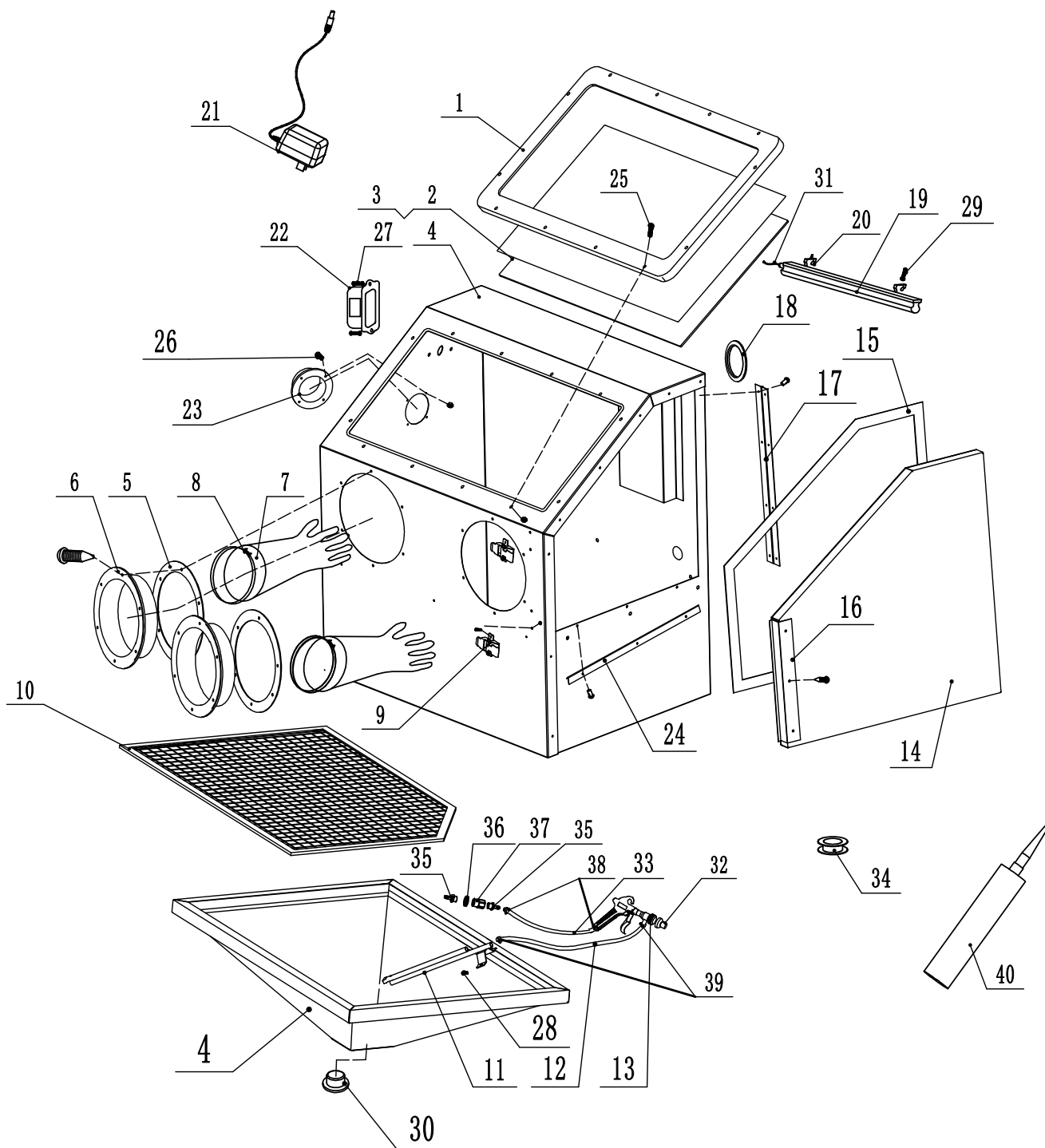

SAFETY

SETUP

OPERATION

MAINTENANCE

Parts List - Blast Gun

SAFETY

Part	Description	Qty
1A	Nozzle Lock	1
2A	Nozzle	4
3A	Air Jet	1
4A	Gun Body	1
5A	Pin	1
6A	O-Ring	1
7A	Round Pin	1
8A	Round Pin Cover	1

Part	Description	Qty
9A	Spring	1
10A	O-Ring	1
11A	Air Vent	1
12A	Air Hose Connector	1
13A	E-Type Rib	1
14A	Handle	1
15A	O-Ring	1
16A	Screw	2

Note: When ordering replacement parts from this list, the "A" suffix must be included in order to get the correct part.

SETUP

OPERATION

MAINTENANCE

CENTRAL[®]
MACHINERY

Assembly Diagram - Blast Gun

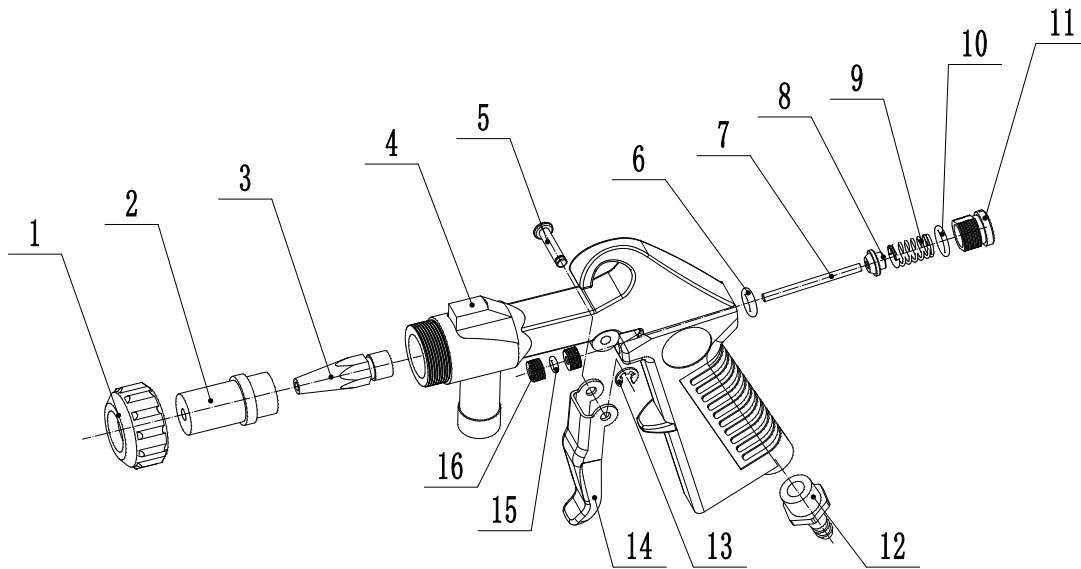

SAFETY

SETUP

OPERATION

MAINTENANCE

CENTRAL[®] MACHINERY

Limited 90 Day Warranty

Harbor Freight Tools Co. makes every effort to assure that its products meet high quality and durability standards, and warrants to the original purchaser that this product is free from defects in materials and workmanship for the period of 90 days from the date of purchase. This warranty does not apply to damage due directly or indirectly, to misuse, abuse, negligence or accidents, repairs or alterations outside our facilities, criminal activity, improper installation, normal wear and tear, or to lack of maintenance. We shall in no event be liable for death, injuries to persons or property, or for incidental, contingent, special or consequential damages arising from the use of our product. Some states do not allow the exclusion or limitation of incidental or consequential damages, so the above limitation of exclusion may not apply to you. THIS WARRANTY IS EXPRESSLY IN LIEU OF ALL OTHER WARRANTIES, EXPRESS OR IMPLIED, INCLUDING THE WARRANTIES OF MERCHANTABILITY AND FITNESS.

To take advantage of this warranty, the product or part must be returned to us with transportation charges prepaid. Proof of purchase date and an explanation of the complaint must accompany the merchandise. If our inspection verifies the defect, we will either repair or replace the product at our election or we may elect to refund the purchase price if we cannot readily and quickly provide you with a replacement. We will return repaired products at our expense, but if we determine there is no defect, or that the defect resulted from causes not within the scope of our warranty, then you must bear the cost of returning the product.

This warranty gives you specific legal rights and you may also have other rights which vary from state to state.

CENTRAL[®]
MACHINERY

26677 Agoura Road • Calabasas, CA 91302 • 1-888-866-5797