

Owner's Manual & Safety Instructions

Save This Manual Keep this manual for the safety warnings and precautions, assembly, operating, inspection, maintenance and cleaning procedures. Write the product's serial number in the back of the manual near the assembly diagram (or month and year of purchase if product has no number). Keep this manual and the receipt in a safe and dry place for future reference.

23a

PITTSBURGH®

CROSS BAR DENT REPAIR KIT



Visit our website at: <http://www.harborfreight.com>
Email our technical support at: productsupport@harborfreight.com

When unpacking, make sure that the product is intact and undamaged. If any parts are missing or broken, please call 1-888-866-5797 as soon as possible.

Copyright© 2022 by Harbor Freight Tools®. All rights reserved.
No portion of this manual or any artwork contained herein may be reproduced in any shape or form without the express written consent of Harbor Freight Tools. Diagrams within this manual may not be drawn proportionally. Due to continuing improvements, actual product may differ slightly from the product described herein.
Tools required for assembly and service may not be included.

⚠WARNING

Read this material before using this product.
Failure to do so can result in serious injury.
SAVE THIS MANUAL.

Specifications

Glue Gun	120VAC / 60Hz / 40W
Crossbar Adjustment	3" to 5"





Important Safety Information

⚠ WARNING

Read all safety warnings and instructions.
Save all warnings and instructions for future reference.

- TO PREVENT ELECTRIC SHOCK: Keep glue gun dry, do not use in rain.**
- Avoid skin contact with tip and melted hot glue.**
- Work in a well ventilated area.**
- Wear ANSI-approved safety goggles and heavy-duty work gloves during use.
- This product is not a toy. Do not allow children to play with or near this tool.
- Use as intended only.
- Inspect before every use; do not use if parts are loose or damaged.
- Maintain product labels and nameplates. These carry important safety information. If unreadable or missing, contact Harbor Freight Tools for a replacement.

WARNING SYMBOLS AND DEFINITIONS

	This is the safety alert symbol. It is used to alert you to potential personal injury hazards. Obey all safety messages that follow this symbol to avoid possible injury or death.
	Indicates a hazardous situation which, if not avoided, will result in death or serious injury.
	Indicates a hazardous situation which, if not avoided, could result in death or serious injury.
	Indicates a hazardous situation which, if not avoided, could result in minor or moderate injury.
	Addresses practices not related to personal injury.

Record Serial Number Here: _____

Note: If product has no serial number, record month and year of purchase instead.

Note: Some parts are listed and shown for illustration purposes only, and are not available individually as replacement parts. Specify UPC 193175483461 when ordering parts.

Instructions

Note: This Kit will not repair ALL dents, regardless of size. **It will not work on aluminum surfaces.**

- Insert Glue Stick into Glue Gun. Plug Glue Gun into grounded 120VAC outlet. Allow to warm up for ten to fifteen minutes before use.

Note: Do not use crafting glue sticks.

- Using clean cloth (not included), clean dent area with Release Agent.

- Choose Pull Tab the same size as dent.
- Apply glue to Pull Tab then quickly place Pull Tab on center of dent and hold there for ten seconds.
- Wait two to three minutes for glue to set before applying puller.

Note: Allow glue to harden completely before attempting to pull, this may take several minutes depending on the quantity of glue used.

Crossbar

1. Place Crossbar over end of Pull Tab, adjust Feet until they are flat against vehicle's surface, then tighten Wing Nuts. Thread Knob onto end of Pull Tab. Continue to turn Knob until dent is raised.
2. Remove Crossbar and Pull Tab. If necessary, apply Release Agent around Pull Tab to soften glue and use Scraper to remove glue.
3. Clean area thoroughly to remove Release Agent residue.

Repairing High Spots

Use a hammer (not included) and lightly tap Shape Stick against raised spot until desired smoothness is reached.

PLEASE READ THE FOLLOWING CAREFULLY

THE MANUFACTURER AND/OR DISTRIBUTOR HAS PROVIDED THE PARTS LIST AND ASSEMBLY DIAGRAM IN THIS DOCUMENT AS A REFERENCE TOOL ONLY. NEITHER THE MANUFACTURER OR DISTRIBUTOR MAKES ANY REPRESENTATION OR WARRANTY OF ANY KIND TO THE BUYER THAT HE OR SHE IS QUALIFIED TO MAKE ANY REPAIRS TO THE PRODUCT, OR THAT HE OR SHE IS QUALIFIED TO REPLACE ANY PARTS OF THE PRODUCT. IN FACT, THE MANUFACTURER AND/OR DISTRIBUTOR EXPRESSLY STATES THAT ALL REPAIRS AND PARTS REPLACEMENTS SHOULD BE UNDERTAKEN BY CERTIFIED AND LICENSED TECHNICIANS, AND NOT BY THE BUYER. THE BUYER ASSUMES ALL RISK AND LIABILITY ARISING OUT OF HIS OR HER REPAIRS TO THE ORIGINAL PRODUCT OR REPLACEMENT PARTS THERETO, OR ARISING OUT OF HIS OR HER INSTALLATION OF REPLACEMENT PARTS THERETO.

Parts List and Assembly Diagram

Parts List

Part	Description	Qty	Part	Description	Qty
1	Glue Gun	1	7	Scraper	1
2	Glue Stick	3	8	Shape Stick	1
3	Release Agent	1	9	Wing Nut	2
4	Oval Pull Tab	1	10	Round Pull Tab	1
5	Cross Bar	1	11	Foot	2
6	Knob	1			

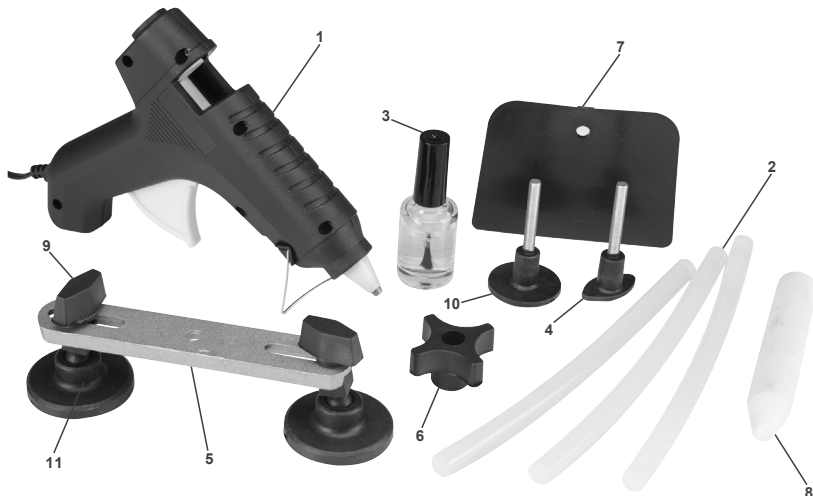

Limited 90 Day Warranty

Harbor Freight Tools Co. makes every effort to assure that its products meet high quality and durability standards, and warrants to the original purchaser that this product is free from defects in materials and workmanship for the period of 90 days from the date of purchase. This warranty does not apply to damage due directly or indirectly, to misuse, abuse, negligence or accidents, repairs or alterations outside our facilities, criminal activity, improper installation, normal wear and tear, or to lack of maintenance. We shall in no event be liable for death, injuries to persons or property, or for incidental, contingent, special or consequential damages arising from the use of our product. Some states do not allow the exclusion or limitation of incidental or consequential damages, so the above limitation of exclusion may not apply to you. THIS WARRANTY IS EXPRESSLY IN LIEU OF ALL OTHER WARRANTIES, EXPRESS OR IMPLIED, INCLUDING THE WARRANTIES OF MERCHANTABILITY AND FITNESS.

To take advantage of this warranty, the product or part must be returned to us with transportation charges prepaid. Proof of purchase date and an explanation of the complaint must accompany the merchandise. If our inspection verifies the defect, we will either repair or replace the product at our election or we may elect to refund the purchase price if we cannot readily and quickly provide you with a replacement. We will return repaired products at our expense, but if we determine there is no defect, or that the defect resulted from causes not within the scope of our warranty, then you must bear the cost of returning the product.

This warranty gives you specific legal rights and you may also have other rights which vary from state to state.

PITTSBURGH[®]

26677 Agoura Road • Calabasas, CA 91302 • 1-888-866-5797