

IMPORTANT SAFETY INFORMATION

Service Cart Safety Warnings

1. Do not ride or climb on cart. Keep away from children.
2. Do not exceed 450 lb. capacity, evenly distributed.
Be aware of dynamic loading!
Sudden load movement may briefly create excess load causing product failure.
3. Use only on a flat, level surface able to support Cart and load.
4. Wear ANSI-approved safety goggles during assembly.
5. Inspect before every use; do not use if parts are loose or damaged.
6. Maintain product labels and nameplates. These carry important safety information. If unreadable or missing, contact Harbor Freight Tools for a replacement.



SAVE THESE INSTRUCTIONS.

Assembly Instructions



Read the **ENTIRE IMPORTANT SAFETY INFORMATION** section at the beginning of this manual including all text under subheadings therein before set up or use of this product.

Note: For additional information regarding the parts listed in the following pages, refer to the Assembly Diagram near the end of this manual.

Unwrap and separate all parts on a clear work area.

Attaching Posts to Bottom Tray

Lay the Bottom Tray (2) (the tray with four sets of four holes on the bottom) on the floor and attach the Posts (7) to the outside corners of the tray using sixteen Short Bolt Sets (9) – 1 Short Bolt, 1 Flat Washer, 1 Lock Washer and 1 Nut per set.

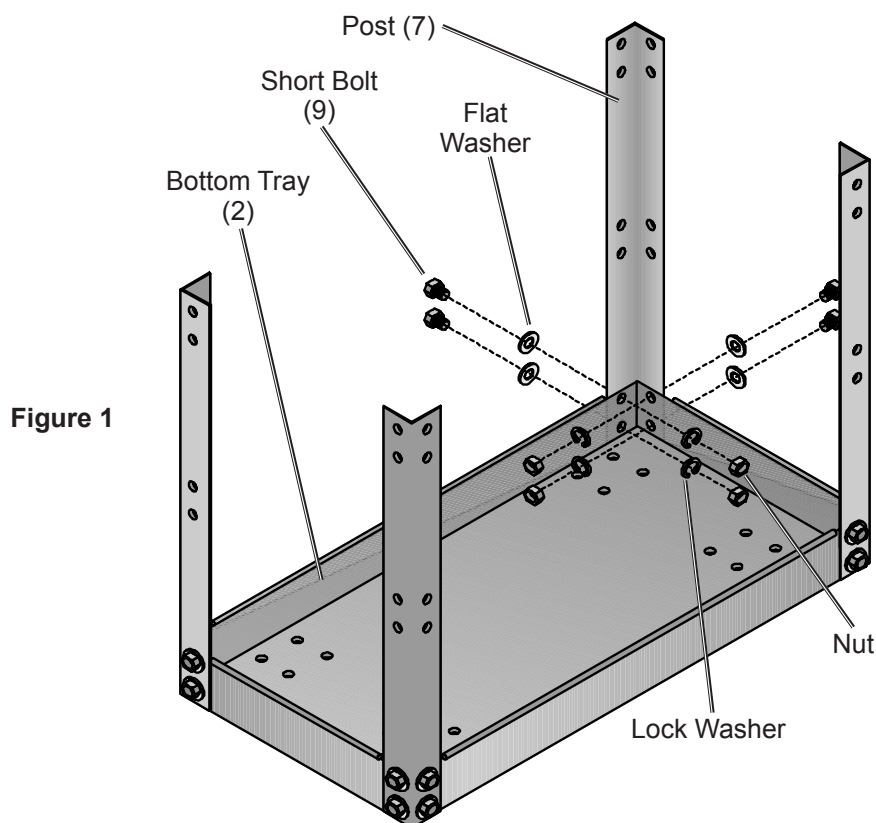

Attaching Middle Tray

Attach Middle Tray (5) to the inside of the posts at all four corners using sixteen Short Bolt Sets (9) – 1 Short Bolt, 1 Flat Washer, 1 Lock Washer and 1 Nut per set.

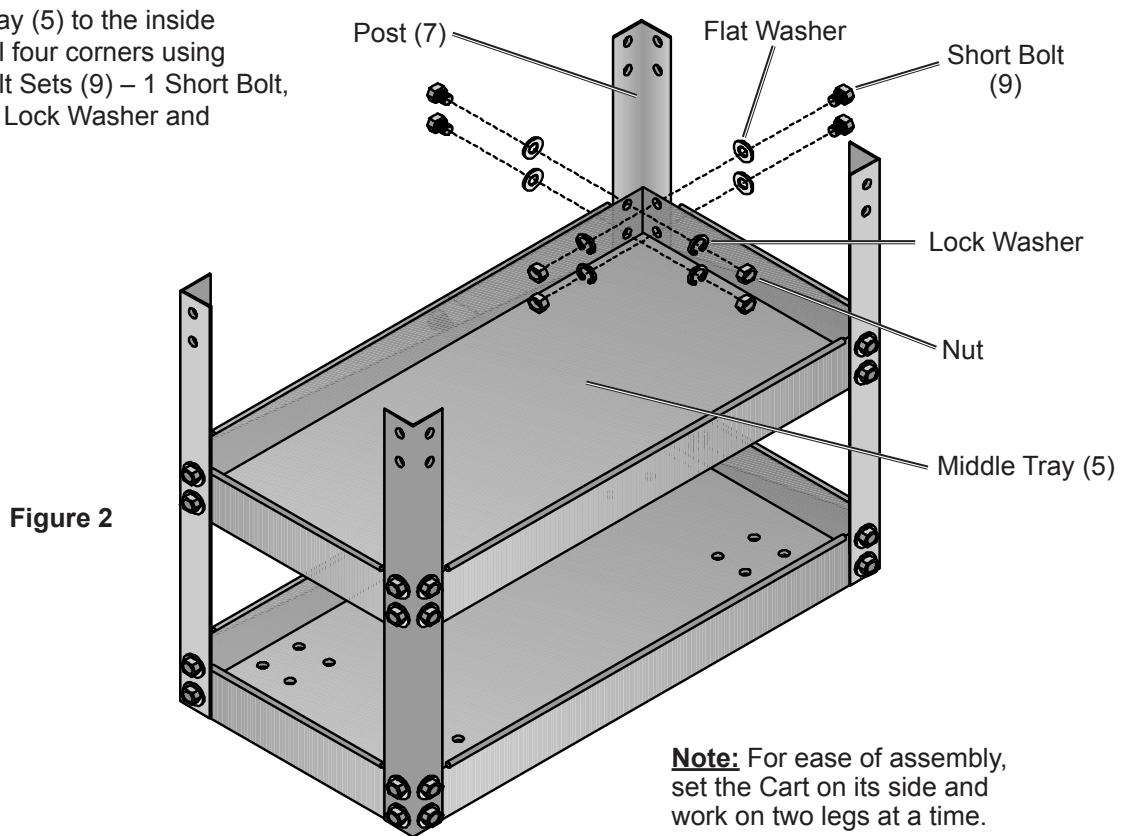

Attaching Top Tray

Attach Top Tray (1) to the inside top of the posts using twelve Short Bolt Sets (9) – 1 Short Bolt, 1 Flat Washer, 1 Lock Washer and 1 Nut per set. (Four holes on one end of the top tray are reserved for attaching the Handle in the next step.)

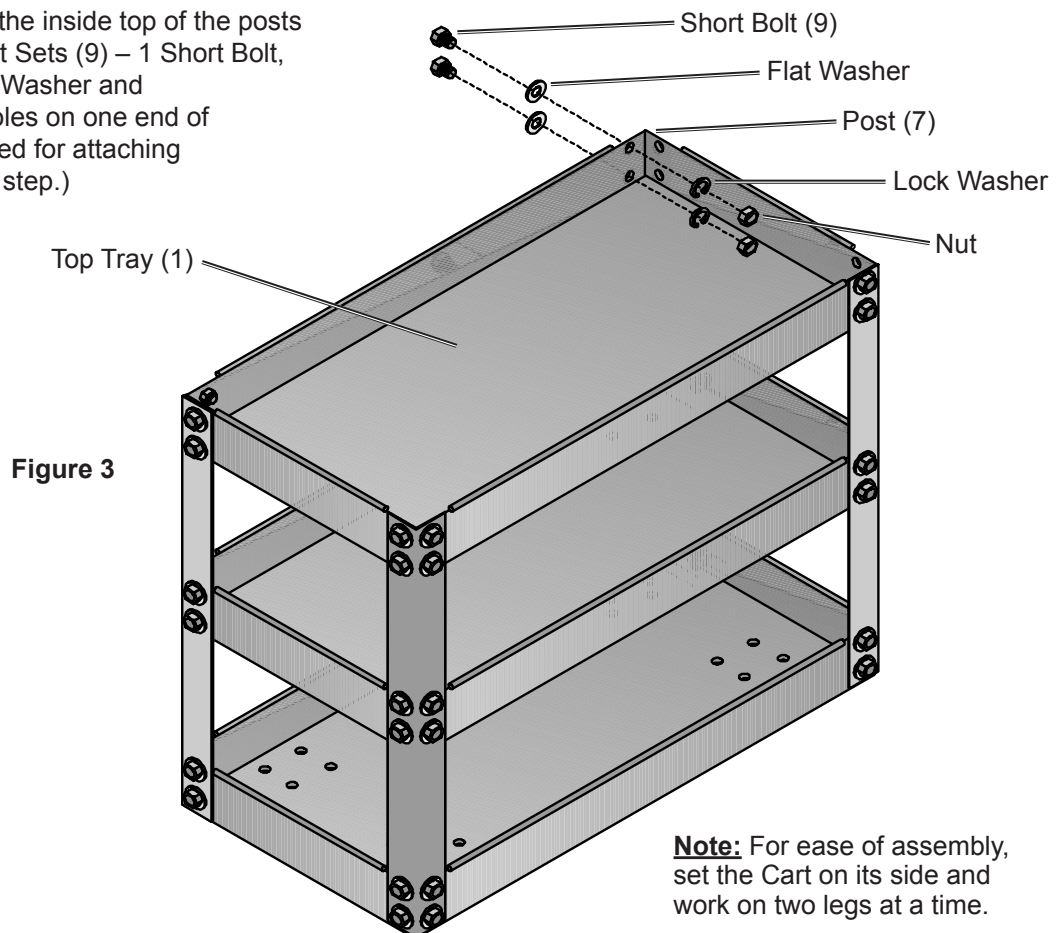

Attaching Handle

Assemble the Handle Brackets (8) onto ends of Handle (4) and attach Handle assembly to end of Posts (7) using four Long Bolt Sets (10) – 1 Long Bolt, 1 Flat Washer, 1 Lock Washer and 1 Nut per set.

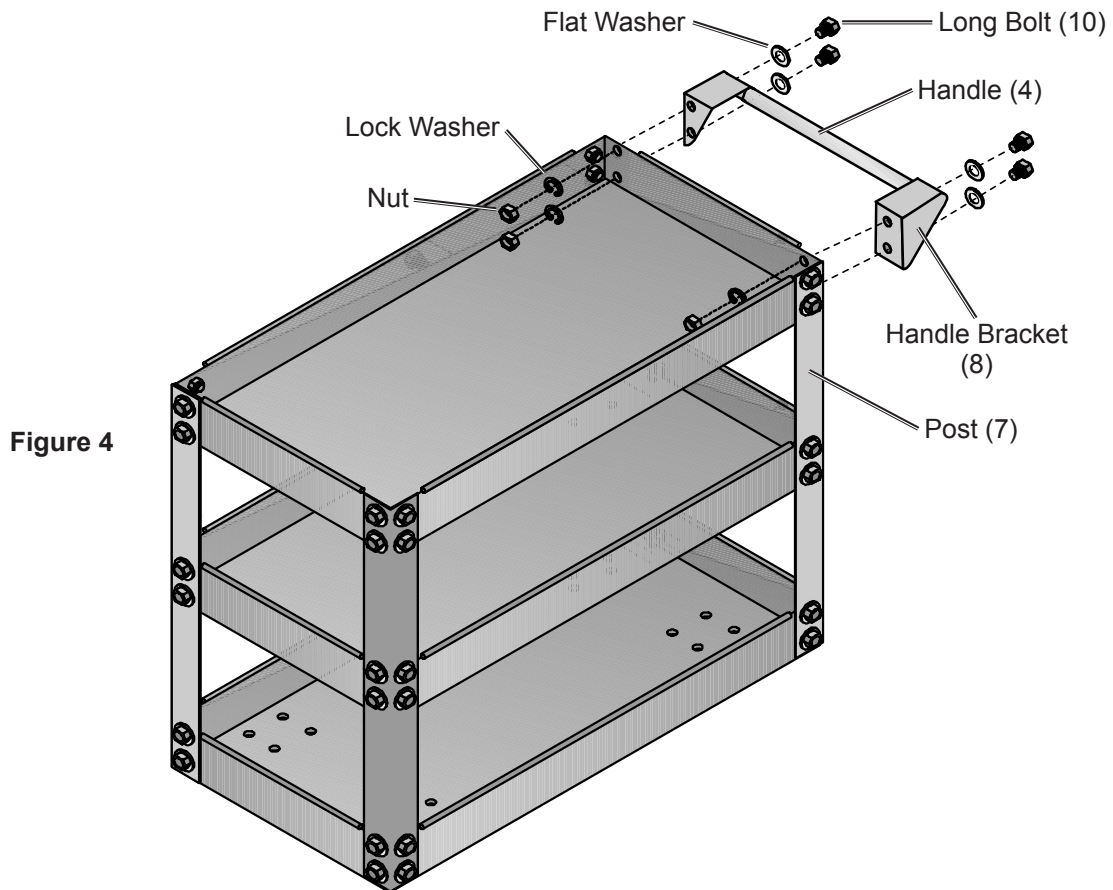

Attaching Wheels

1. Decide on which end of the cart to mount the pair of Rigid Wheels (6) and pair of Swivel Wheels (3). For example, mounting the Fixed Wheels on the Handle end of the Cart will make a push cart like those in a grocery store.
2. Attach each Fixed Wheel to one end of the Bottom Tray using four Wheel Bolt Sets (11) per wheel – 1 Wheel Bolt, 1 Lock Washer and 1 Nut per set.
3. Attach each Swivel Wheel to the remaining end of the Bottom Tray using the remaining Wheel Bolt Sets (11) – 1 Wheel Bolt, 1 Lock Washer and 1 Nut per set.

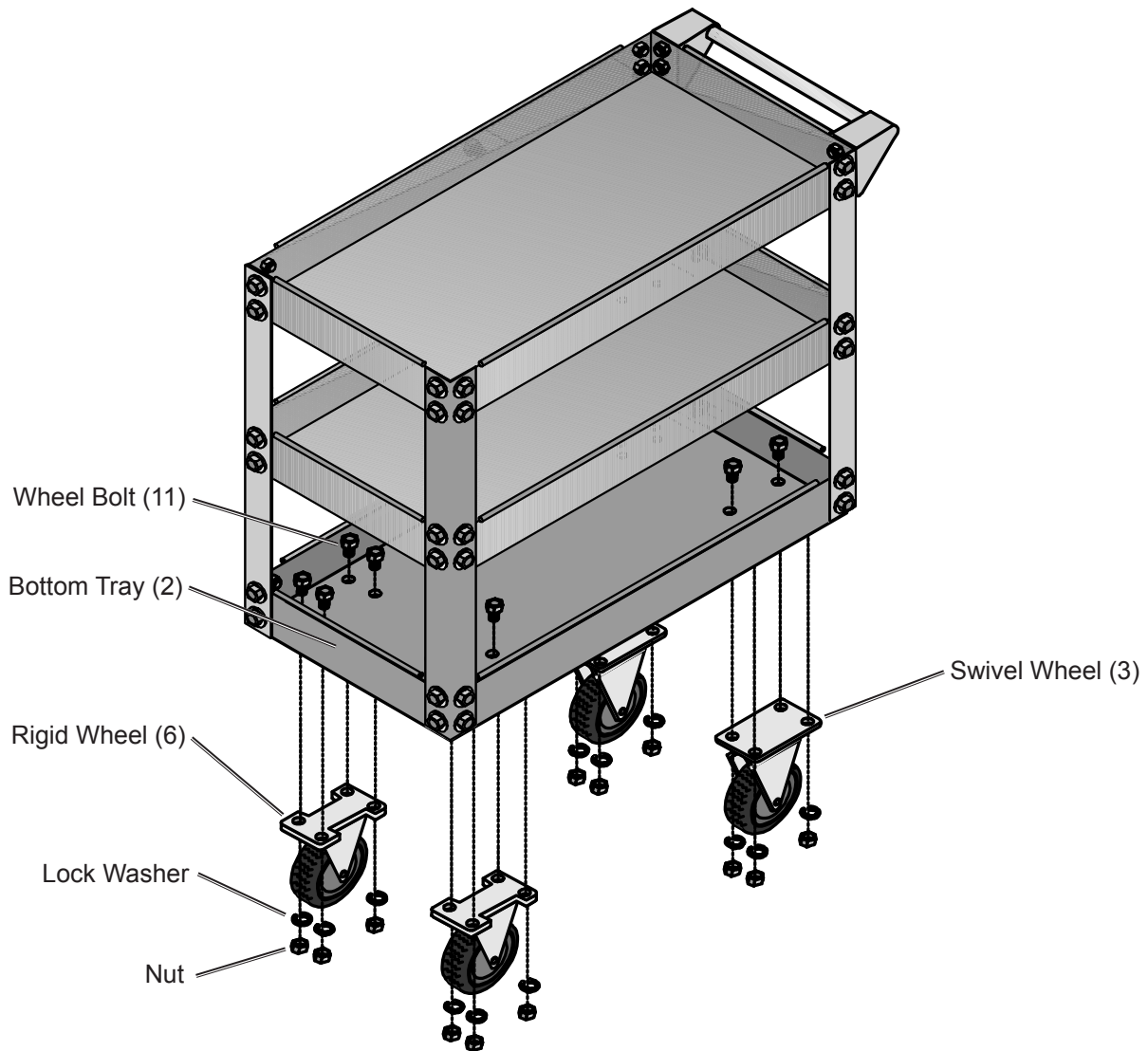

Figure 5

Specifications

Capacity	450 lb.
Tray Depth	3-1/2"
Wheels	5" Rubber Casters
Dimensions	30" L x 16" W x 32-1/2" H

PLEASE READ THE FOLLOWING CAREFULLY

THE MANUFACTURER AND/OR DISTRIBUTOR HAS PROVIDED THE PARTS LIST AND ASSEMBLY DIAGRAM IN THIS DOCUMENT AS A REFERENCE TOOL ONLY. NEITHER THE MANUFACTURER OR DISTRIBUTOR MAKES ANY REPRESENTATION OR WARRANTY OF ANY KIND TO THE BUYER THAT HE OR SHE IS QUALIFIED TO MAKE ANY REPAIRS TO THE PRODUCT, OR THAT HE OR SHE IS QUALIFIED TO REPLACE ANY PARTS OF THE PRODUCT. IN FACT, THE MANUFACTURER AND/OR DISTRIBUTOR EXPRESSLY STATES THAT ALL REPAIRS AND PARTS REPLACEMENTS SHOULD BE UNDERTAKEN BY CERTIFIED AND LICENSED TECHNICIANS, AND NOT BY THE BUYER. THE BUYER ASSUMES ALL RISK AND LIABILITY ARISING OUT OF HIS OR HER REPAIRS TO THE ORIGINAL PRODUCT OR REPLACEMENT PARTS THERETO, OR ARISING OUT OF HIS OR HER INSTALLATION OF REPLACEMENT PARTS THERETO.

Record Product's Serial Number Here: _____

Note: If product has no serial number, record month and year of purchase instead.

Note: Some parts are listed and shown for illustration purposes only, and are not available individually as replacement parts.

Parts List and Assembly Diagram

Part	Description	Qty
1	Top Tray	1
2	Bottom Tray	1
3	Swivel Wheel	2
4	Handle	1
5	Middle Tray	1
6	Rigid Wheel	2

Part	Description	Qty
7	Post	4
8	Handle Bracket	2
9	Short Bolt Set M6x12	44
10	Long Bolt Set M6x14	4
11	Wheel Bolt Set M10x15	16

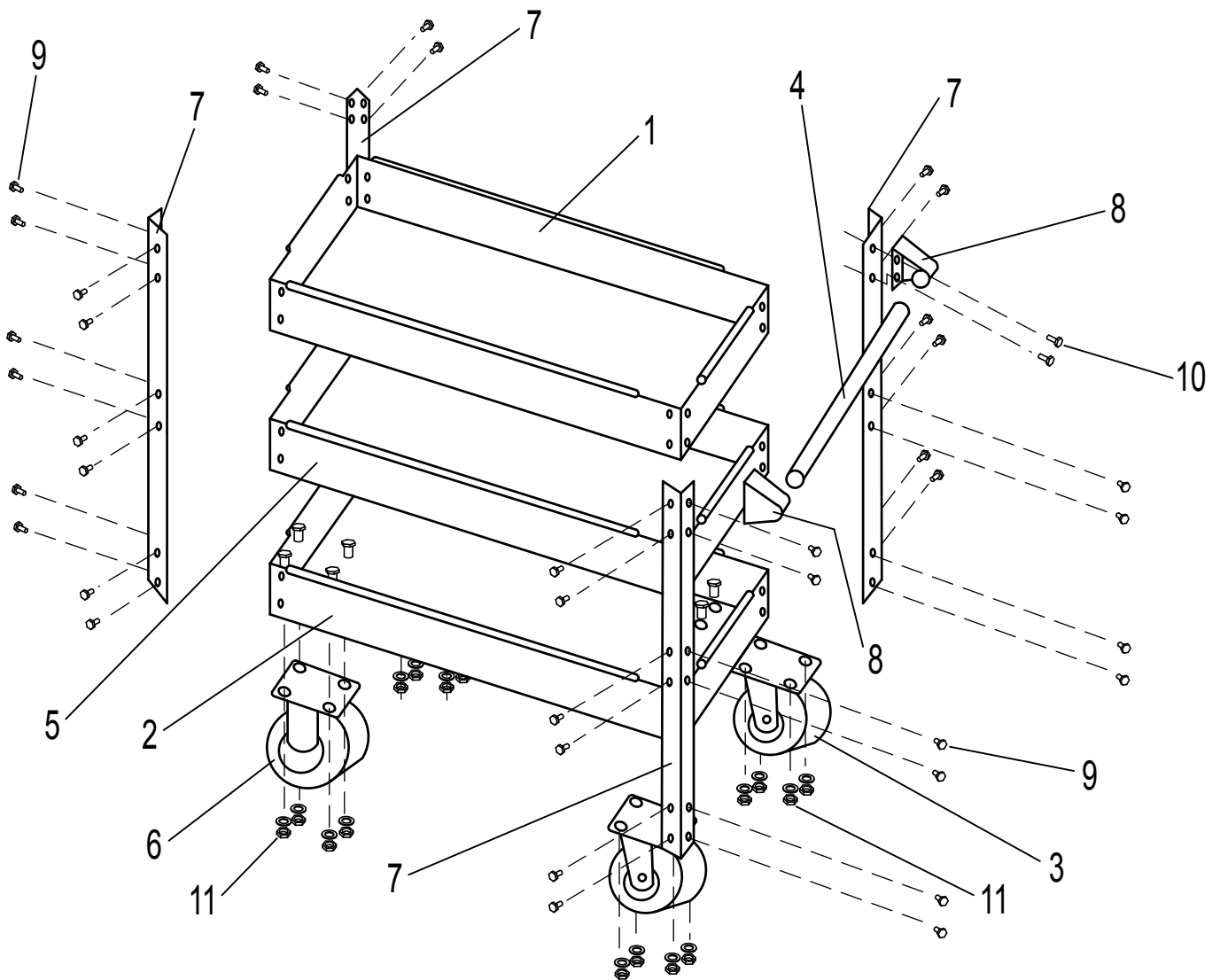

Limited 90 Day Warranty

Harbor Freight Tools Co. makes every effort to assure that its products meet high quality and durability standards, and warrants to the original purchaser that this product is free from defects in materials and workmanship for the period of 90 days from the date of purchase. This warranty does not apply to damage due directly or indirectly, to misuse, abuse, negligence or accidents, repairs or alterations outside our facilities, criminal activity, improper installation, normal wear and tear, or to lack of maintenance. We shall in no event be liable for death, injuries to persons or property, or for incidental, contingent, special or consequential damages arising from the use of our product. Some states do not allow the exclusion or limitation of incidental or consequential damages, so the above limitation of exclusion may not apply to you. THIS WARRANTY IS EXPRESSLY IN LIEU OF ALL OTHER WARRANTIES, EXPRESS OR IMPLIED, INCLUDING THE WARRANTIES OF MERCHANTABILITY AND FITNESS.

To take advantage of this warranty, the product or part must be returned to us with transportation charges prepaid. Proof of purchase date and an explanation of the complaint must accompany the merchandise. If our inspection verifies the defect, we will either repair or replace the product at our election or we may elect to refund the purchase price if we cannot readily and quickly provide you with a replacement. We will return repaired products at our expense, but if we determine there is no defect, or that the defect resulted from causes not within the scope of our warranty, then you must bear the cost of returning the product.

This warranty gives you specific legal rights and you may also have other rights which vary from state to state.



3491 Mission Oaks Blvd. • PO Box 6009 • Camarillo, CA 93011 • (800) 444-3353