

# Owner's Manual & Safety Instructions

**Save This Manual** Keep this manual for the safety warnings and precautions, assembly, operating, inspection, maintenance and cleaning procedures. Write the product's serial number in the back of the manual near the assembly diagram (or month and year of purchase if product has no number). Keep this manual and the receipt in a safe and dry place for future reference.

20h

# **PITTSBURGH<sup>®</sup> AUTOMOTIVE**

**6530**

## **FARM JACK**

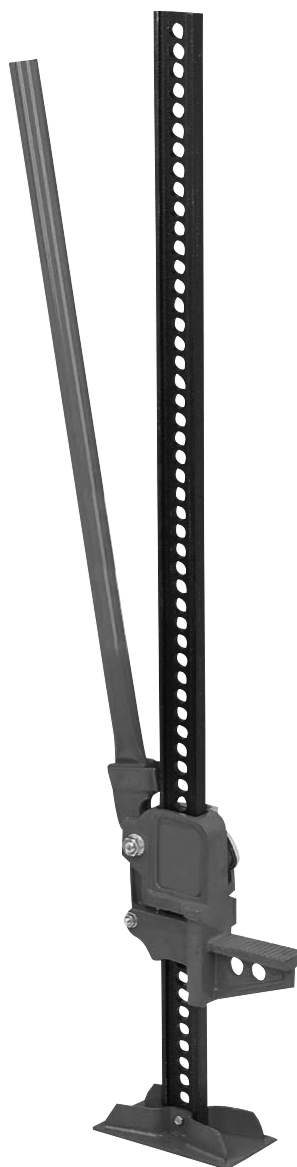

Visit our website at: <http://www.harborfreight.com>  
Email our technical support at: [productsupport@harborfreight.com](mailto:productsupport@harborfreight.com)

When unpacking, make sure that the product is intact and undamaged. If any parts are missing or broken, please call 1-888-866-5797 as soon as possible.

Copyright© 2013 by Harbor Freight Tools®. All rights reserved.  
No portion of this manual or any artwork contained herein may be reproduced in any shape or form without the express written consent of Harbor Freight Tools. Diagrams within this manual may not be drawn proportionally. Due to continuing improvements, actual product may differ slightly from the product described herein.  
Tools required for assembly and service may not be included.

### **⚠ WARNING**





Read this material before using this product.  
Failure to do so can result in serious injury.  
**SAVE THIS MANUAL.**

## Specifications

Weight Capacity	7000 lb.
Lifting Arm	4-1/2" x 1-1/2"
Base Dimensions	7" x 4"

Maximum Lift Height	42"
Minimum Lift Height	5"

### WARNING SYMBOLS AND DEFINITIONS

	This is the safety alert symbol. It is used to alert you to potential personal injury hazards. Obey all safety messages that follow this symbol to avoid possible injury or death.
	Indicates a hazardous situation which, if not avoided, will result in death or serious injury.
	Indicates a hazardous situation which, if not avoided, could result in death or serious injury.
	Indicates a hazardous situation which, if not avoided, could result in minor or moderate injury.
	Addresses practices not related to personal injury.

## IMPORTANT SAFETY INFORMATION

### WARNING

Read all safety warnings and instructions.

Save all warnings and instructions for future reference.

Failure to heed these markings may result in personal injury and/or property damage:

1. Study, understand, and follow all instructions before operating this device.
2. Do not exceed 7000 lb. rated capacity.
3. Use only on hard, flat, level surfaces.
4. Lifting device only. Immediately after lifting, support the vehicle with appropriate means.
5. Wear ANSI-approved safety goggles and heavy-duty work gloves during use.
6. Keep clear of load while lifting and lowering.
7. Lower load slowly in controlled fashion. Do not allow load to drop quickly.
8. Do not use for aircraft purposes.
9. Inspect before every use; do not use if parts loose or damaged.
10. Do not alter the jack or use attachments and/or adapters that are not supplied by the manufacturer. Any alterations or modifications to this tool may result in dangerous conditions.
11. Be aware of dynamic loading! Sudden load movement may briefly create excess load causing product failure.
12. Maintain labels and nameplates on the tool. These carry important safety information. If unreadable or missing, contact Harbor Freight Tools for a replacement.
13. This product is not a toy. Keep it out of reach of children.
14. The warnings, precautions, and instructions discussed in this manual cannot cover all possible conditions and situations that may occur. The operator must understand that common sense and caution are factors, which cannot be built into this product, but must be supplied by the operator.



**SAVE THESE INSTRUCTIONS.**

# Components

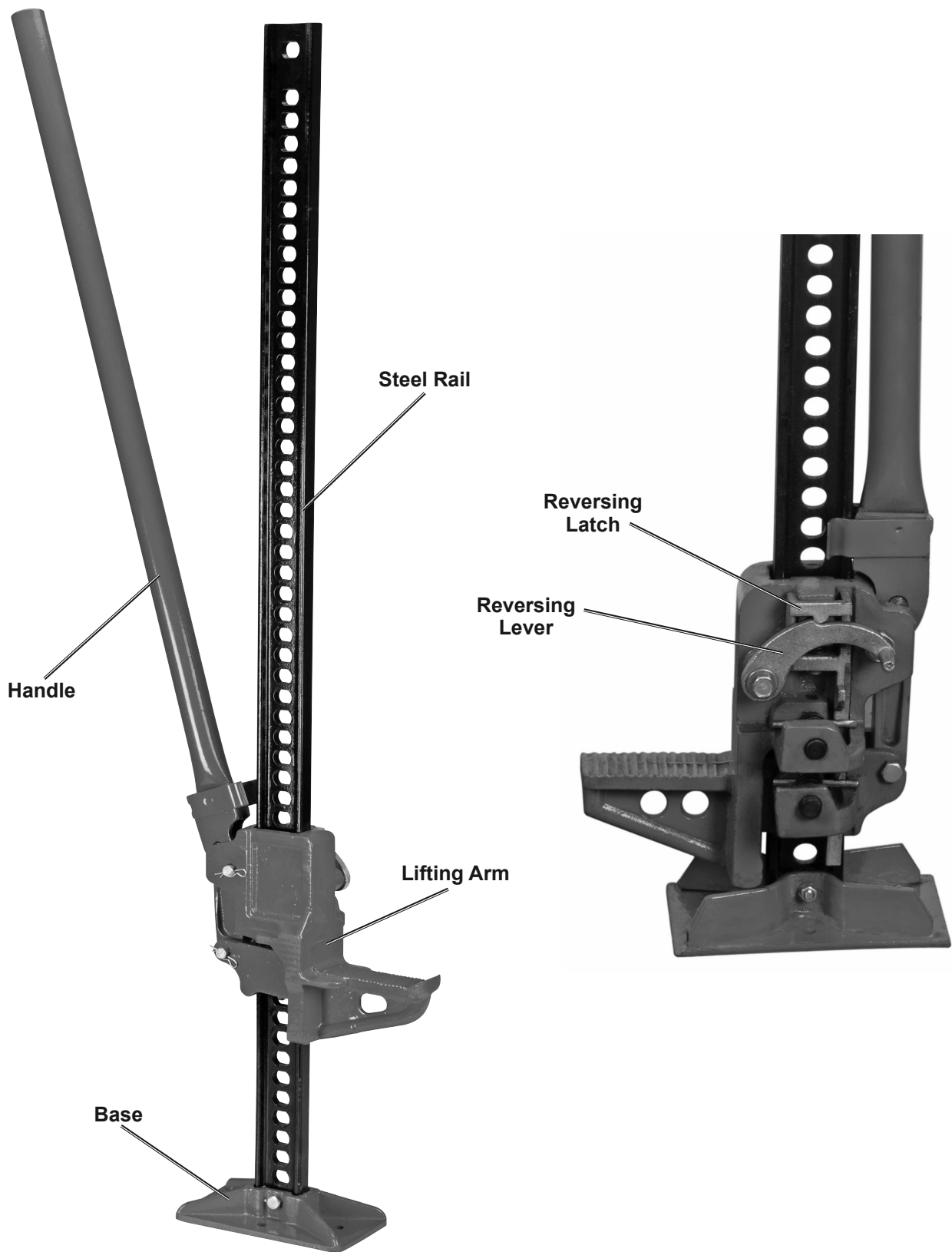

## Operation



Read **ENTIRE IMPORTANT SAFETY INFORMATION** section at beginning of this manual including all text under subheadings therein before set up or use of this product.

**Note:** For additional information regarding the parts listed in the following pages, refer to *Parts List and Diagram* on page 6.

## Lifting a Load

1. Place the Jack on a stable area to prevent shifting or slipping.
2. With the Reversing Lever (10) in the down position, move the Lifting Arm (1) to the desired position on the Steel Rail (2) and place the Lifting Arm completely under the object to be lifted.

**Note:** When the Reversing Lever is in the down position and there is no load on the Jack, the ratcheting mechanism allows the Lifting Arm to move freely up or down on the Steel Rail.

3. To raise the load, pull up on the Reversing Lever until the notch on the Lever engages the protrusion on the Reversing Latch (11), locking it in the up position. See Figure A.
4. Slowly pump the Handle (4) to raise the load. Always keep a firm grip on the Handle while operating the Jack.
5. After the load is raised to the desired height, insert a Grade 5, 1/2" bolt (sold separately) through the hole in the Steel Rail immediately below the lifting mechanism as a safety precaution.

### **WARNING! TO PREVENT SERIOUS INJURY:**

Dynamic loading may under certain circumstances create a situation where the actual weight being held or lifted is far in excess of Jack or bolt capacity. **DO NOT** drop weight onto the Lifting Arm, or allow sudden motion of the Lifting Arm, as this may shear the 1/2" bolt or cause the Jack to fail.

6. Insert additional supports to make sure the load is properly supported at the lift point to prevent shifting.

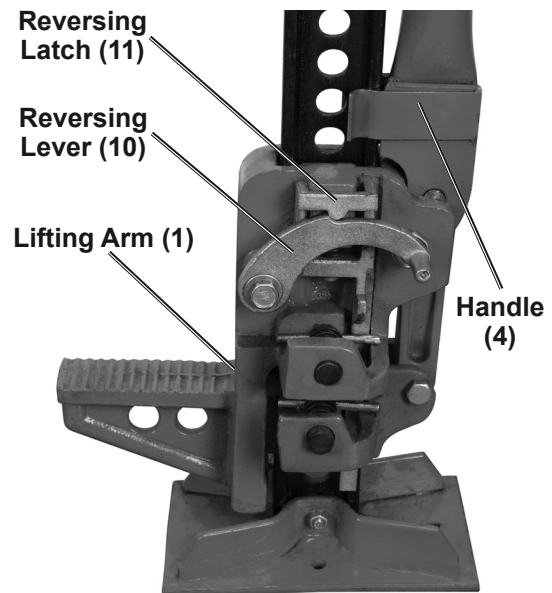

Figure A: Reversing Lever in *Up* Position

**PITTSBURGH** AUTOMOTIVE

## Lowering a Load

1. Place the Handle (4) in the upright position and remove the 1/2" safety bolt placed through the Steel Rail (2) before tripping the Reversing Lever (10) to lower the load.

**Note:** To lower loads one raised level at a time, the Jack must be loaded with 110 lb. (50 kg) or more. Otherwise, the Lifting Arm (1) will drop when the Reversing Lever is placed in the down position.

2. Place the Reversing Lever in the down position. See Figure B.
3. Slowly pump the Handle to lower the load. Continue pumping the Handle until the load rests on the ground.
4. Clean, then store the tool indoors out of children's reach.

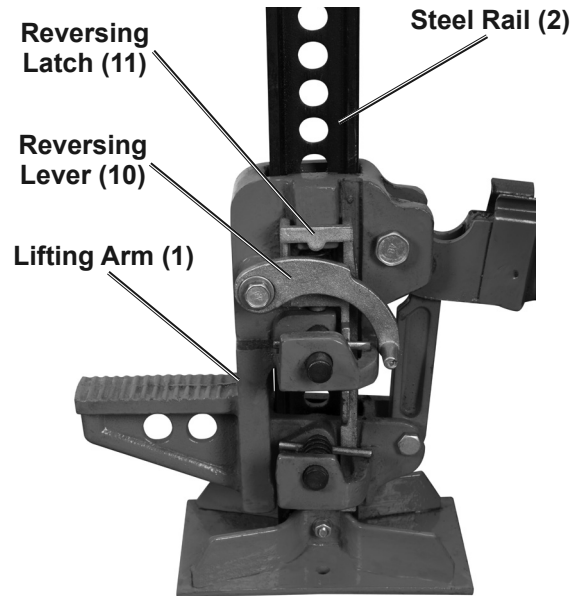

Figure B: Reversing Lever in *Down* Position

## User-Maintenance Instructions



Procedures not specifically explained in this manual must be performed only by a qualified technician.

### **⚠️ WARNING**

#### **TO PREVENT SERIOUS INJURY FROM TOOL FAILURE:**

Do not use damaged equipment. If abnormal noise occurs, have the problem corrected before further use.

#### **TO PREVENT SERIOUS INJURY:**

Remove load from the jack before any procedure on this page.

1. **BEFORE EACH USE**, inspect the general condition of the equipment. Check for:
  - loose hardware
  - misalignment or binding of moving parts
  - cracked or broken parts
  - any other condition that may affect its safe operation.
2. Before each use and after the inspection, thoroughly test the Jack for proper operation prior to its actual use.
3. **PERIODICALLY**, lubricate moving parts of the Jack with lubricating oil. The front and back of the Steel Rail must be kept rust free.
4. **AFTER USE**, clean the tool with clean cloth. Store the Jack in a safe, dry location out of reach of children and other non-authorized people.

**PITTSBURGH** ® **AUTOMOTIVE**

### PLEASE READ THE FOLLOWING CAREFULLY

THE MANUFACTURER AND/OR DISTRIBUTOR HAS PROVIDED THE PARTS LIST AND ASSEMBLY DIAGRAM IN THIS MANUAL AS A REFERENCE TOOL ONLY. NEITHER THE MANUFACTURER OR DISTRIBUTOR MAKES ANY REPRESENTATION OR WARRANTY OF ANY KIND TO THE BUYER THAT HE OR SHE IS QUALIFIED TO MAKE ANY REPAIRS TO THE PRODUCT, OR THAT HE OR SHE IS QUALIFIED TO REPLACE ANY PARTS OF THE PRODUCT. IN FACT, THE MANUFACTURER AND/OR DISTRIBUTOR EXPRESSLY STATES THAT ALL REPAIRS AND PARTS REPLACEMENTS SHOULD BE UNDERTAKEN BY CERTIFIED AND LICENSED TECHNICIANS, AND NOT BY THE BUYER. THE BUYER ASSUMES ALL RISK AND LIABILITY ARISING OUT OF HIS OR HER REPAIRS TO THE ORIGINAL PRODUCT OR REPLACEMENT PARTS THERETO, OR ARISING OUT OF HIS OR HER INSTALLATION OF REPLACEMENT PARTS THERETO.

### Parts List

Part	Description	Qty
1	Lifting Arm	1
2	Steel Rail	1
3	Connecting Rod	1
4	Handle	1
5	Washer	1
6	R-Clip	1
7	Pin	1
8	Screw	1
9	Washer	1
10	Reversing Lever	1
11	Reversing Latch	1
12	Pin	1
13	Nut	1

Part	Description	Qty
14	Washer	1
15	Base	1
16	Bolt	1
17	Pin	1
18	Spring	1
19	Reverse Rod Pin	2
20	Reverse Rod	2
21	Spring	1
22	Spring	1
23	Washer	1
24	R-Clip	1
25	Small Runner	1
26	Spring Washer	1

Record Product's Serial Number Here: \_\_\_\_\_

**Note:** If product has no serial number, record month and year of purchase instead.

**Note:** Some parts are listed and shown for illustration purposes only, and are not available individually as replacement parts. Specify UPC 193175319050 when ordering parts.

**PITTSBURGH** AUTOMOTIVE

# Assembly Diagram

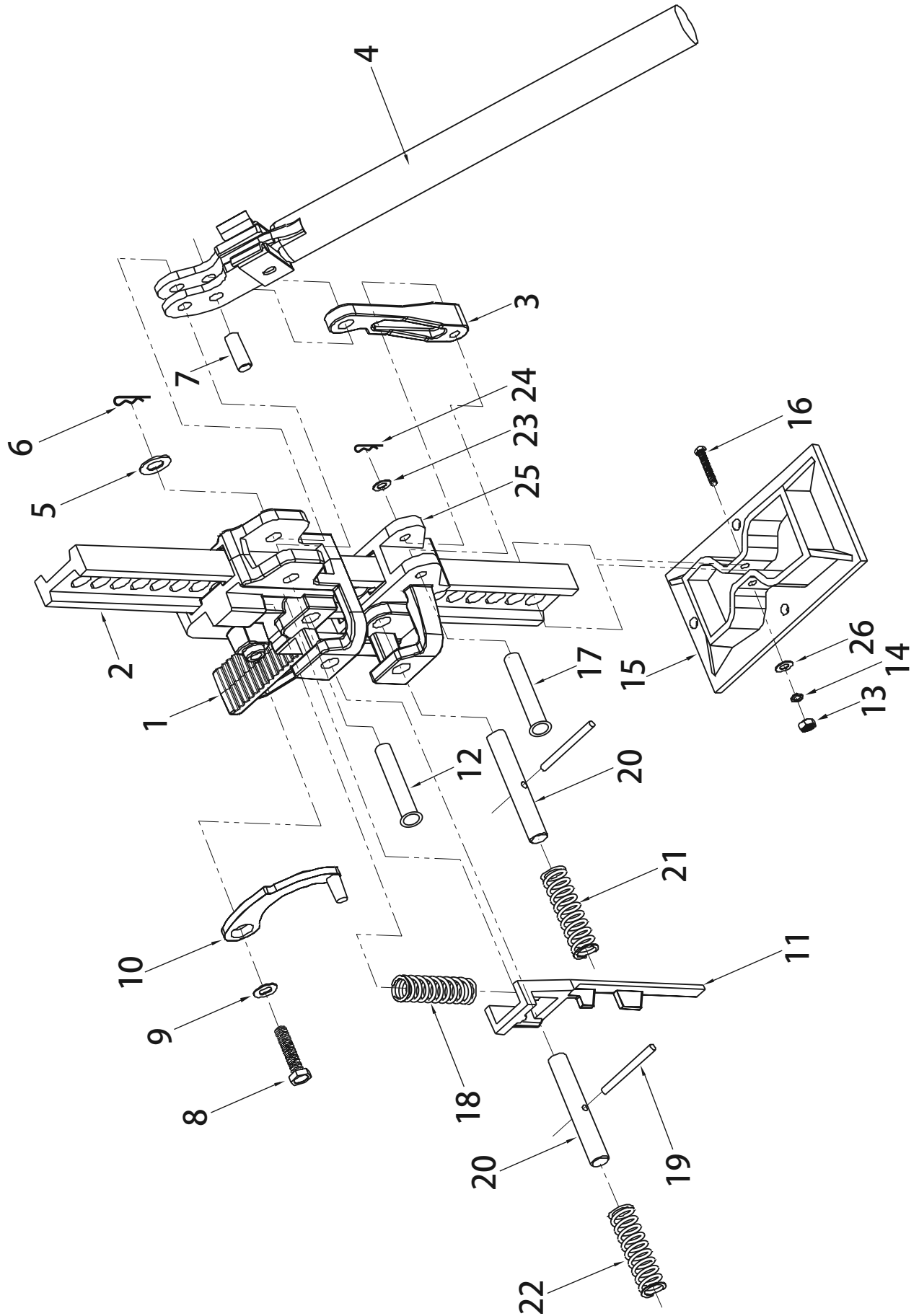

## Limited 90 Day Warranty

Harbor Freight Tools Co. makes every effort to assure that its products meet high quality and durability standards, and warrants to the original purchaser that this product is free from defects in materials and workmanship for the period of 90 days from the date of purchase. This warranty does not apply to damage due directly or indirectly, to misuse, abuse, negligence or accidents, repairs or alterations outside our facilities, criminal activity, improper installation, normal wear and tear, or to lack of maintenance. We shall in no event be liable for death, injuries to persons or property, or for incidental, contingent, special or consequential damages arising from the use of our product. Some states do not allow the exclusion or limitation of incidental or consequential damages, so the above limitation of exclusion may not apply to you. THIS WARRANTY IS EXPRESSLY IN LIEU OF ALL OTHER WARRANTIES, EXPRESS OR IMPLIED, INCLUDING THE WARRANTIES OF MERCHANTABILITY AND FITNESS.

To take advantage of this warranty, the product or part must be returned to us with transportation charges prepaid. Proof of purchase date and an explanation of the complaint must accompany the merchandise. If our inspection verifies the defect, we will either repair or replace the product at our election or we may elect to refund the purchase price if we cannot readily and quickly provide you with a replacement. We will return repaired products at our expense, but if we determine there is no defect, or that the defect resulted from causes not within the scope of our warranty, then you must bear the cost of returning the product.

This warranty gives you specific legal rights and you may also have other rights which vary from state to state.

**PITTSBURGH<sup>®</sup> AUTOMOTIVE**

26541 Agoura Road • Calabasas, CA 91302 • 1-888-866-5797