

# Owner's Manual & Safety Instructions

**Save This Manual** Keep this manual for the safety warnings and precautions, assembly, operating, inspection, maintenance and cleaning procedures. Write the product's serial number in the back of the manual near the assembly diagram (or month and year of purchase if product has no number). Keep this manual and the receipt in a safe and dry place for future reference.

20e



## Steel Mesh Deck Wagon

4 Ft. X 2 Ft. Deck



60359

Visit our website at: <http://www.harborfreight.com>  
Email our technical support at: [productsupport@harborfreight.com](mailto:productsupport@harborfreight.com)

When unpacking, make sure that the product is intact and undamaged. If any parts are missing or broken, please call 1-888-866-5797 as soon as possible.

Copyright© 2019 by Harbor Freight Tools®. All rights reserved.  
No portion of this manual or any artwork contained herein may be reproduced in any shape or form without the express written consent of Harbor Freight Tools. Diagrams within this manual may not be drawn proportionally. Due to continuing improvements, actual product may differ slightly from the product described herein. Tools required for assembly and service may not be included.

### ⚠ WARNING

Read this material before using this product. Failure to do so can result in serious injury. SAVE THIS MANUAL.

## Specifications

|          |                     |
|----------|---------------------|
| Capacity | 1000 lb             |
| Wheels   | 10" Pneumatic Tires |

## IMPORTANT SAFETY INFORMATION



### **WARNING** Read all safety warnings and instructions.

*Failure to follow the warnings and instructions may result in serious injury.*

**Save all warnings and instructions for future reference.**

1. **DO NOT ALLOW CHILDREN TO PLAY WITH OR AROUND THE WAGON. NOT A TOY.**
2. **Do not ride on this wagon.**
3. Do not exceed 1000 lb. weight capacity, evenly distributed.
4. When loading and unloading the wagon, be careful of the balance of the wagon.
5. Be careful of the Handle which can tip and fall from the upright position.
6. Chock the four wheels before loading or unloading the wagon.
7. Wear ANSI-approved safety goggles during assembly.
8. Inspect before every use; do not use if parts are loose or damaged.
9. Maintain product labels and nameplates. These carry important safety information. If unreadable or missing, contact Harbor Freight Tools for a replacement.



**SAVE THESE INSTRUCTIONS.**

## Assembly

1. Turn the Bed Assembly (1) upside down. Use the cardboard from the carton to keep from scratching or damaging the finish.
2. Attach the Handle (3) to the Steering Bracket using one each Bolt (4), Flat Washer M8 (5), and Lock Nut (6). Tighten securely.

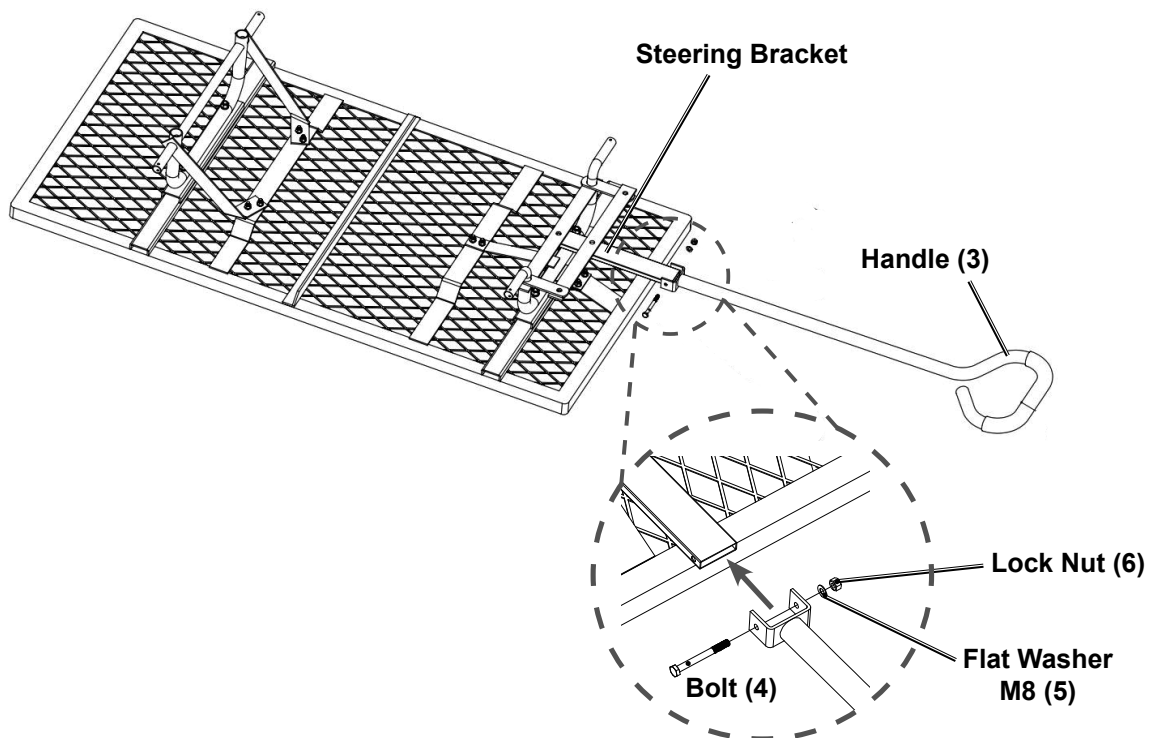

3. Connect the Wheels (2) by sliding two onto the Front Axle and two onto the Rear Axel. Secure each wheel with a Flat Washer M16 (7) and Cotter Pin (8).
4. To attach Cotter Pin, insert it through hole at the end of the Axle and bend each end of pin in opposite directions to secure Wheel. Repeat for all wheels.

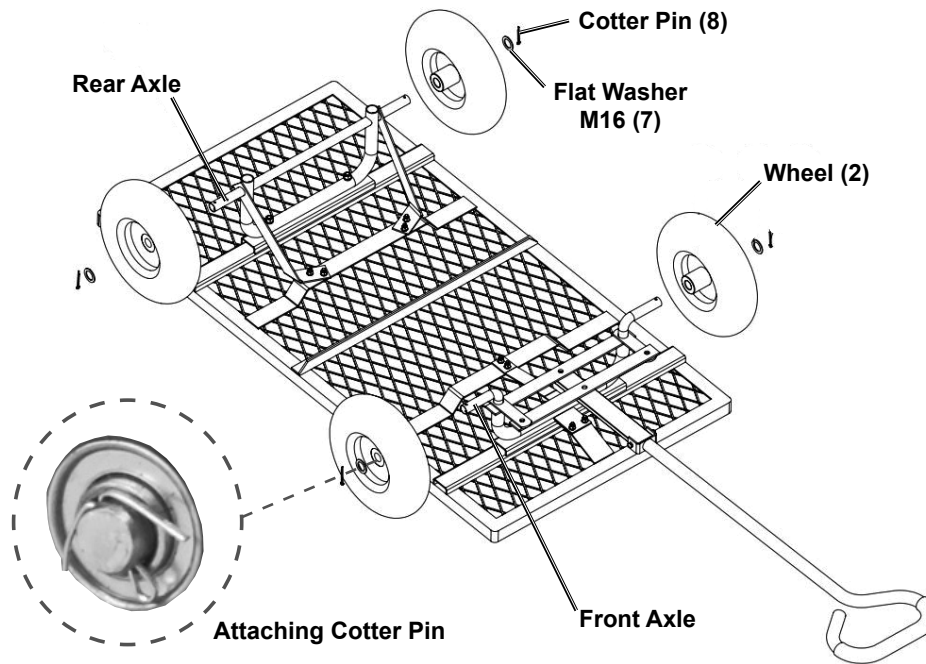

## Operation

1. Test all hardware for tightness before turning the Wagon over on its wheels.
2. Roll the Wagon to check for proper wheel operation.
3. Make sure the combined weight of all items loaded on Wagon does not exceed the weight capacity.
4. Make sure the Wagon's load is well balanced and secure.

## Maintenance



Procedures not specifically explained in this manual must be performed only by a qualified technician.

### **WARNING**

**TO PREVENT SERIOUS INJURY FROM TOOL FAILURE:**

**Do not use damaged equipment. If any part becomes damaged, have the problem corrected before further use.**

1. **PERIODICALLY**, inspect the general condition of the Wagon. Check for:
  - loose hardware,
  - misalignment or binding of moving parts,
  - cracked or broken parts,
  - any other condition that may affect its safe operation.
2. Periodically check tire inflation (maximum tire inflation is 30 PSI).
3. Periodically lubricate wheel axles.

## PLEASE READ THE FOLLOWING CAREFULLY

THE MANUFACTURER AND/OR DISTRIBUTOR HAS PROVIDED THE PARTS LIST AND ASSEMBLY DIAGRAM IN THIS MANUAL AS A REFERENCE TOOL ONLY. NEITHER THE MANUFACTURER OR DISTRIBUTOR MAKES ANY REPRESENTATION OR WARRANTY OF ANY KIND TO THE BUYER THAT HE OR SHE IS QUALIFIED TO MAKE ANY REPAIRS TO THE PRODUCT, OR THAT HE OR SHE IS QUALIFIED TO REPLACE ANY PARTS OF THE PRODUCT. IN FACT, THE MANUFACTURER AND/OR DISTRIBUTOR EXPRESSLY STATES THAT ALL REPAIRS AND PARTS REPLACEMENTS SHOULD BE UNDERTAKEN BY CERTIFIED AND LICENSED TECHNICIANS, AND NOT BY THE BUYER. THE BUYER ASSUMES ALL RISK AND LIABILITY ARISING OUT OF HIS OR HER REPAIRS TO THE ORIGINAL PRODUCT OR REPLACEMENT PARTS THERETO, OR ARISING OUT OF HIS OR HER INSTALLATION OF REPLACEMENT PARTS THERETO.

## Parts List and Assembly Diagram

| Part | Description   | Qty |
|------|---------------|-----|
| 1    | Bed Assembly  | 1   |
| 2    | Wheel         | 4   |
| 3    | Handle        | 1   |
| 4    | Bolt, M8 x 60 | 1   |

| Part | Description        | Qty |
|------|--------------------|-----|
| 5    | Flat Washer, M8    | 1   |
| 6    | Lock Nut, M8       | 1   |
| 7    | Flat Washer, M16   | 4   |
| 8    | Cotter Pin, 3 x 30 | 4   |

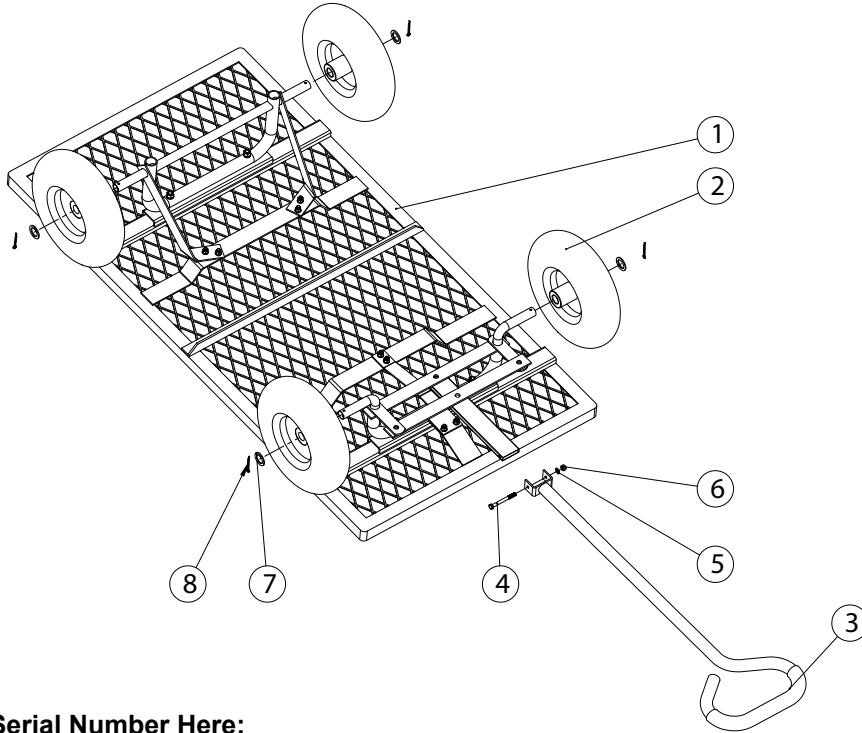

Record Product's Serial Number Here:

**Note:** If product has no serial number, record month and year of purchase instead.

**Note:** Some parts are listed and shown for illustration purposes only, and are not available individually as replacement parts. Specify UPC 193175364340 when ordering parts.

### Limited 90 Day Warranty

Harbor Freight Tools Co. makes every effort to assure that its products meet high quality and durability standards, and warrants to the original purchaser that this product is free from defects in materials and workmanship for the period of 90 days from the date of purchase. This warranty does not apply to damage due directly or indirectly, to misuse, abuse, negligence or accidents, repairs or alterations outside our facilities, criminal activity, improper installation, normal wear and tear, or to lack of maintenance. We shall in no event be liable for death, injuries to persons or property, or for incidental, contingent, special or consequential damages arising from the use of our product. Some states do not allow the exclusion or limitation of incidental or consequential damages, so the above limitation of exclusion may not apply to you. THIS WARRANTY IS EXPRESSLY IN LIEU OF ALL OTHER WARRANTIES, EXPRESS OR IMPLIED, INCLUDING THE WARRANTIES OF MERCHANTABILITY AND FITNESS.

To take advantage of this warranty, the product or part must be returned to us with transportation charges prepaid. Proof of purchase date and an explanation of the complaint must accompany the merchandise. If our inspection verifies the defect, we will either repair or replace the product at our election or we may elect to refund the purchase price if we cannot readily and quickly provide you with a replacement. We will return repaired products at our expense, but if we determine there is no defect, or that the defect resulted from causes not within the scope of our warranty, then you must bear the cost of returning the product.

This warranty gives you specific legal rights and you may also have other rights which vary from state to state.

