

Owner's Manual & Safety Instructions

Save This Manual Keep this manual for the safety warnings and precautions, assembly, operating, inspection, maintenance and cleaning procedures. Write the product's serial number in the back of the manual near the assembly diagram (or month and year of purchase if product has no number). Keep this manual and the receipt in a safe and dry place for future reference.

ITEM 60390

US★GENERAL®

16" x 30" Two Shelf 220 lb. Capacity Steel Service Cart



Visit our website at: <http://www.harborfreight.com>
Email our technical support at: tech@harborfreight.com

When unpacking, make sure that the product is intact and undamaged. If any parts are missing or broken, please call 1-800-444-3353 as soon as possible.

Copyright© 2012 by Harbor Freight Tools®. All rights reserved.
No portion of this manual or any artwork contained herein may be reproduced in any shape or form without the express written consent of Harbor Freight Tools. Diagrams within this manual may not be drawn proportionally. Due to continuing improvements, actual product may differ slightly from the product described herein. Tools required for assembly and service may not be included.

⚠ WARNING

**Read this material before using this product.
Failure to do so can result in serious injury.
SAVE THIS MANUAL.**

IMPORTANT SAFETY INFORMATION

Service Cart Safety Warnings

1. Do not ride or climb on cart. Keep away from children.
2. Do not exceed 220 lb. capacity, evenly distributed.
Be aware of dynamic loading!
Sudden load movement may briefly create excess load causing product failure.
3. Use only on a flat, level surface able to support Cart and load.
4. Wear ANSI-approved safety goggles during assembly.
5. Inspect before every use; do not use if parts are loose or damaged.
6. Maintain product labels and nameplates. These carry important safety information. If unreadable or missing, contact Harbor Freight Tools for a replacement.



SAVE THESE INSTRUCTIONS.

Assembly Instructions



Read the **ENTIRE IMPORTANT SAFETY INFORMATION** section at the beginning of this manual including all text under subheadings therein before set up or use of this product.

Note: For additional information regarding the parts listed in the following pages, refer to the Assembly Diagram near the end of this manual. 10mm, 14mm and 17mm sockets and/or wrenches are required for assembly.

Unwrap and separate all parts on a clear work area.

Attaching Posts to Bottom Tray

Lay the Bottom Tray (2) (the tray with four sets of four holes on the bottom) on the floor and attach the Posts (7) to the outside corners of the tray using sixteen Bolts (9), Washers (11), Lock Washers (10), and Nuts (8).

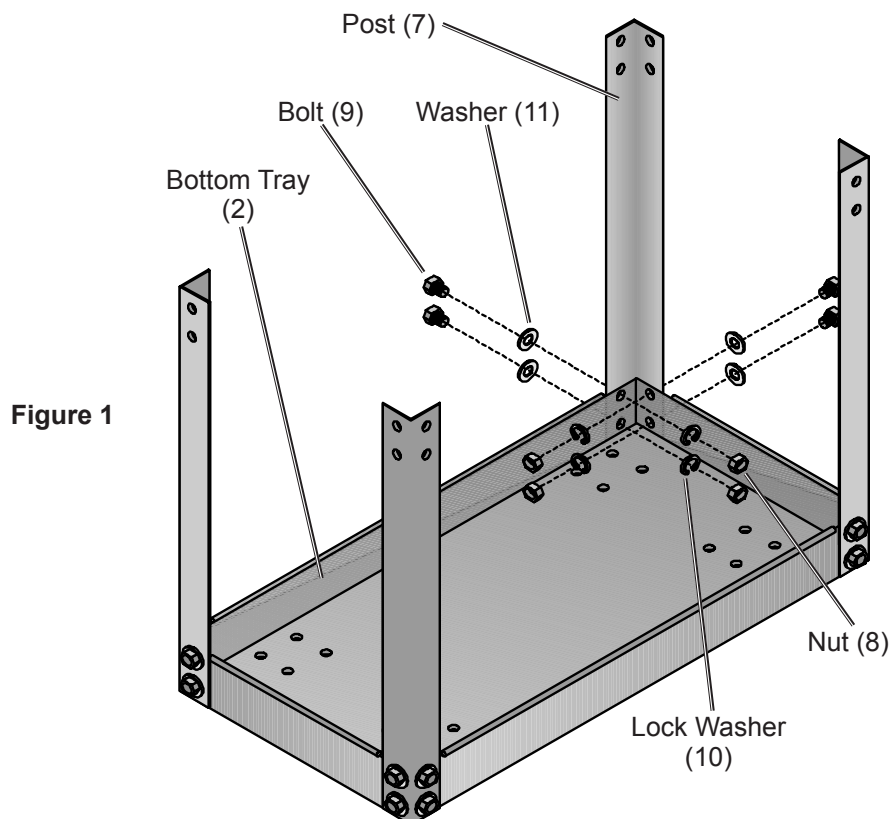

Attaching Top Tray

Attach Top Tray (1) to the other end of the legs using twelve Bolts (9), Washers (11), Lock Washers (10), and Nuts (8). (Four holes on one end of the top tray are reserved for attaching the Handle in the next step.)

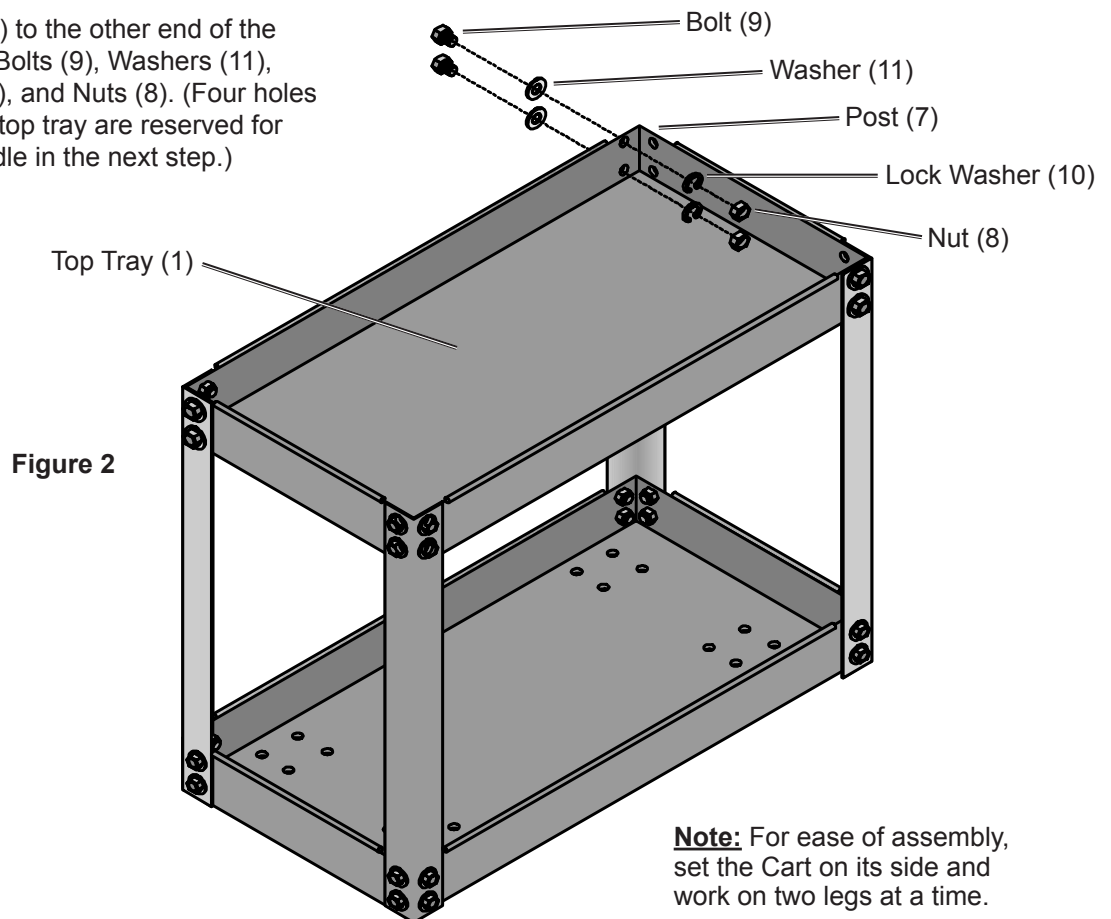

Attaching Handle

Assemble the Handle Brackets (6) onto ends of Handle (4) and attach Handle to end of Posts (7) using four Bolts (12), Washers (11), Lock Washers (10), and Nuts (8).

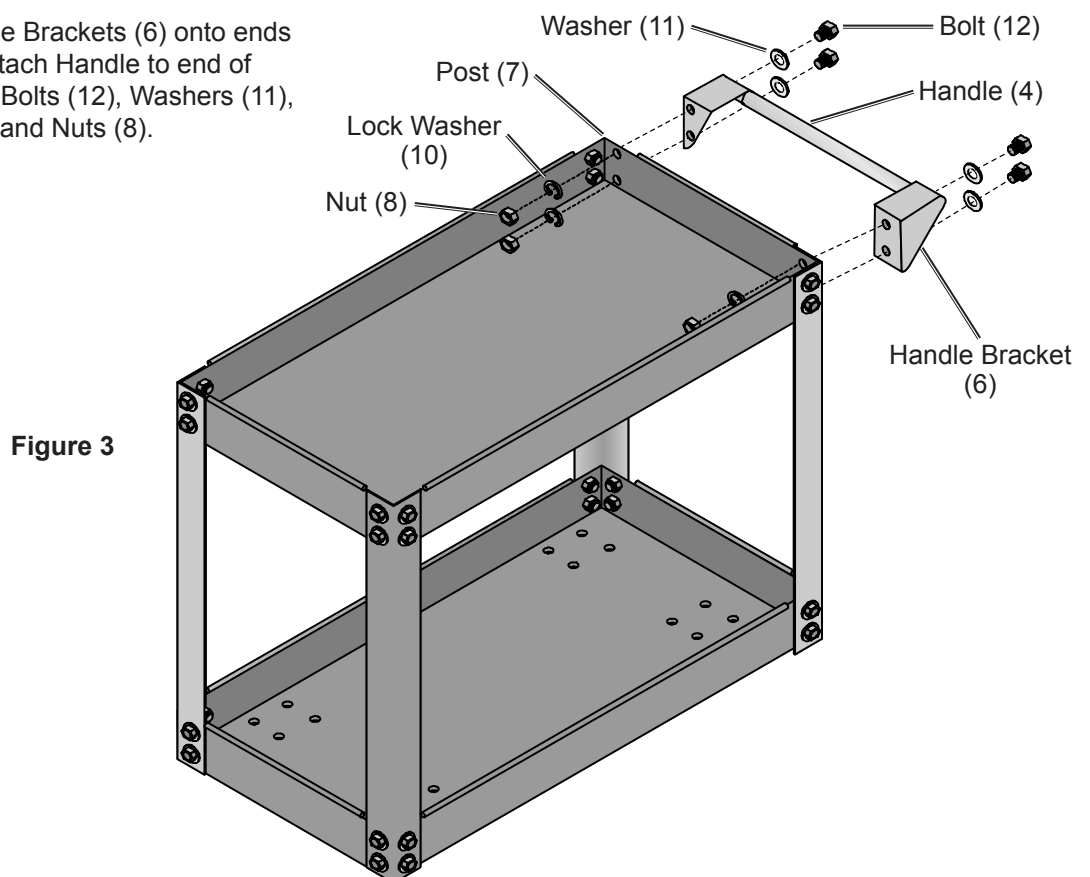

Attaching Wheels

1. Decide on which end of the cart to mount the pair of Rigid Wheels (5) and pair of Swivel Wheels (3). For example, mounting the Fixed Wheels on the Handle end of the Cart will make a push cart like those in a grocery store.
2. Attach each Fixed Wheel to one end of the Bottom Tray using four Bolts (13), Lock Washers (14) and Nuts (15).
3. Attach each Swivel Wheel to the remaining end of the Bottom Tray using the remaining Bolts (13), Lock Washers (14) and Nuts (15).

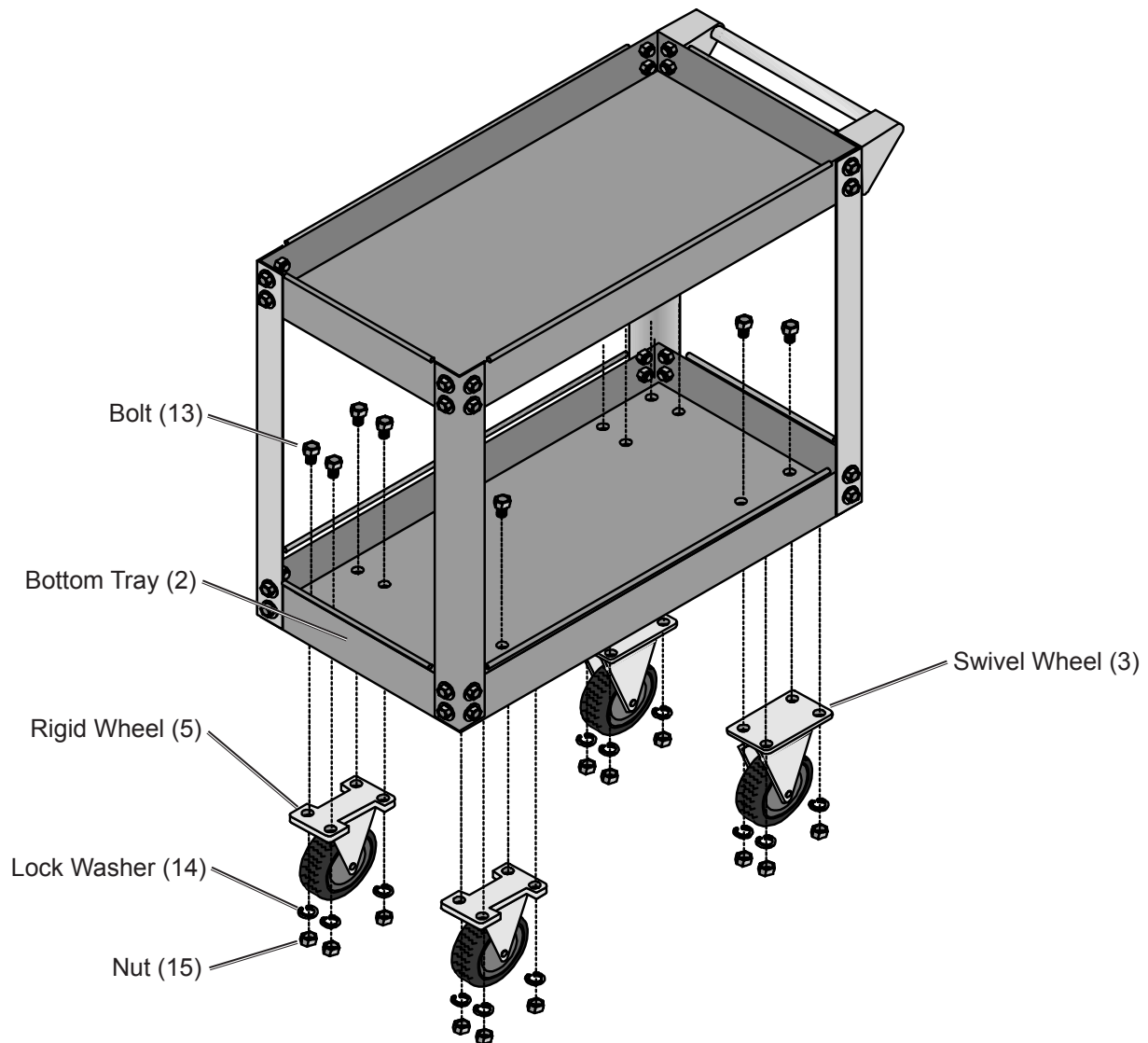

Figure 4

Specifications

| | |
|------------|---------------------------|
| Capacity | 220 lb. |
| Tray Depth | 3-1/2" |
| Wheels | 4" Rubber Casters |
| Dimensions | 33-1/4" L x 16" W x 31" H |

US ★ **GENERAL**®

PLEASE READ THE FOLLOWING CAREFULLY

THE MANUFACTURER AND/OR DISTRIBUTOR HAS PROVIDED THE PARTS LIST AND ASSEMBLY DIAGRAM IN THIS DOCUMENT AS A REFERENCE TOOL ONLY. NEITHER THE MANUFACTURER OR DISTRIBUTOR MAKES ANY REPRESENTATION OR WARRANTY OF ANY KIND TO THE BUYER THAT HE OR SHE IS QUALIFIED TO MAKE ANY REPAIRS TO THE PRODUCT, OR THAT HE OR SHE IS QUALIFIED TO REPLACE ANY PARTS OF THE PRODUCT. IN FACT, THE MANUFACTURER AND/OR DISTRIBUTOR EXPRESSLY STATES THAT ALL REPAIRS AND PARTS REPLACEMENTS SHOULD BE UNDERTAKEN BY CERTIFIED AND LICENSED TECHNICIANS, AND NOT BY THE BUYER. THE BUYER ASSUMES ALL RISK AND LIABILITY ARISING OUT OF HIS OR HER REPAIRS TO THE ORIGINAL PRODUCT OR REPLACEMENT PARTS THERETO, OR ARISING OUT OF HIS OR HER INSTALLATION OF REPLACEMENT PARTS THERETO.

Record Product's Serial Number Here: _____

Note: If product has no serial number, record month and year of purchase instead.

Note: Some parts are listed and shown for illustration purposes only, and are not available individually as replacement parts.

Parts List and Assembly Diagram

| Part | Description | Qty |
|------|----------------|-----|
| 1 | Top Tray | 1 |
| 2 | Bottom Tray | 1 |
| 3 | Swivel Wheel | 2 |
| 4 | Handle | 1 |
| 5 | Rigid Wheel | 2 |
| 6 | Handle Bracket | 2 |
| 7 | Post | 4 |
| 8 | Nut M6 | 32 |

| Part | Description | Qty |
|------|-------------|-----|
| 9 | Bolt M6x12 | 28 |
| 10 | Lock Washer | 32 |
| 11 | Washer | 32 |
| 12 | Bolt M6x15 | 4 |
| 13 | Bolt M8x12 | 16 |
| 14 | Lock Washer | 16 |
| 15 | Nut M8 | 16 |

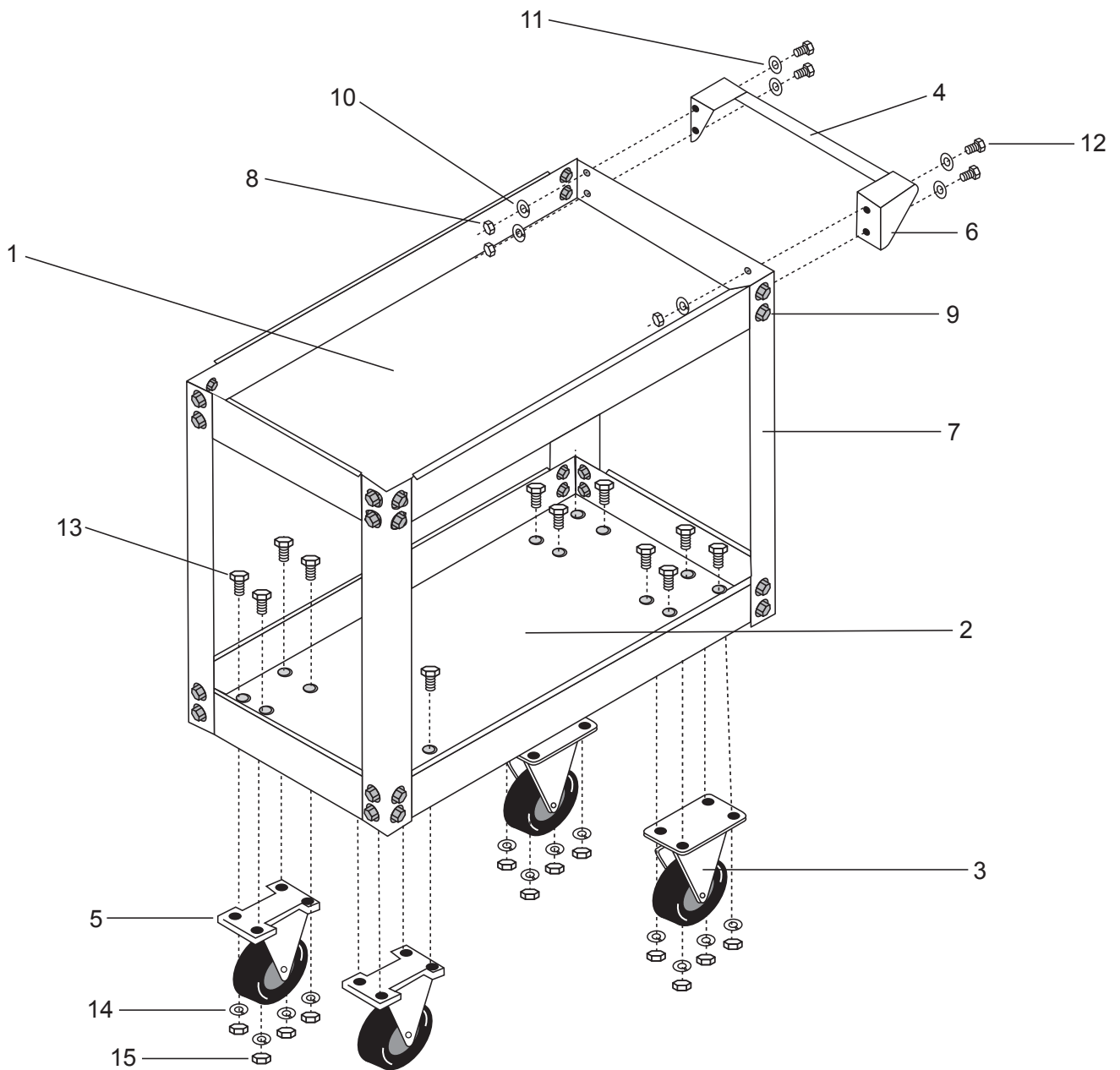

Limited 90 Day Warranty

Harbor Freight Tools Co. makes every effort to assure that its products meet high quality and durability standards, and warrants to the original purchaser that this product is free from defects in materials and workmanship for the period of 90 days from the date of purchase. This warranty does not apply to damage due directly or indirectly, to misuse, abuse, negligence or accidents, repairs or alterations outside our facilities, criminal activity, improper installation, normal wear and tear, or to lack of maintenance. We shall in no event be liable for death, injuries to persons or property, or for incidental, contingent, special or consequential damages arising from the use of our product. Some states do not allow the exclusion or limitation of incidental or consequential damages, so the above limitation of exclusion may not apply to you. THIS WARRANTY IS EXPRESSLY IN LIEU OF ALL OTHER WARRANTIES, EXPRESS OR IMPLIED, INCLUDING THE WARRANTIES OF MERCHANTABILITY AND FITNESS.

To take advantage of this warranty, the product or part must be returned to us with transportation charges prepaid. Proof of purchase date and an explanation of the complaint must accompany the merchandise. If our inspection verifies the defect, we will either repair or replace the product at our election or we may elect to refund the purchase price if we cannot readily and quickly provide you with a replacement. We will return repaired products at our expense, but if we determine there is no defect, or that the defect resulted from causes not within the scope of our warranty, then you must bear the cost of returning the product.

This warranty gives you specific legal rights and you may also have other rights which vary from state to state.



3491 Mission Oaks Blvd. • PO Box 6009 • Camarillo, CA 93011 • (800) 444-3353