

Owner's Manual & Safety Instructions

Save This Manual Keep this manual for the safety warnings and precautions, assembly, operating, inspection, maintenance and cleaning procedures. Write the product's serial number in the back of the manual near the assembly diagram (or month and year of purchase if product has no number). Keep this manual and the receipt in a safe and dry place for future reference.

CHICAGO ELECTRIC  **WELDING**

80W PLASTIC WELDING KIT WITH IRON

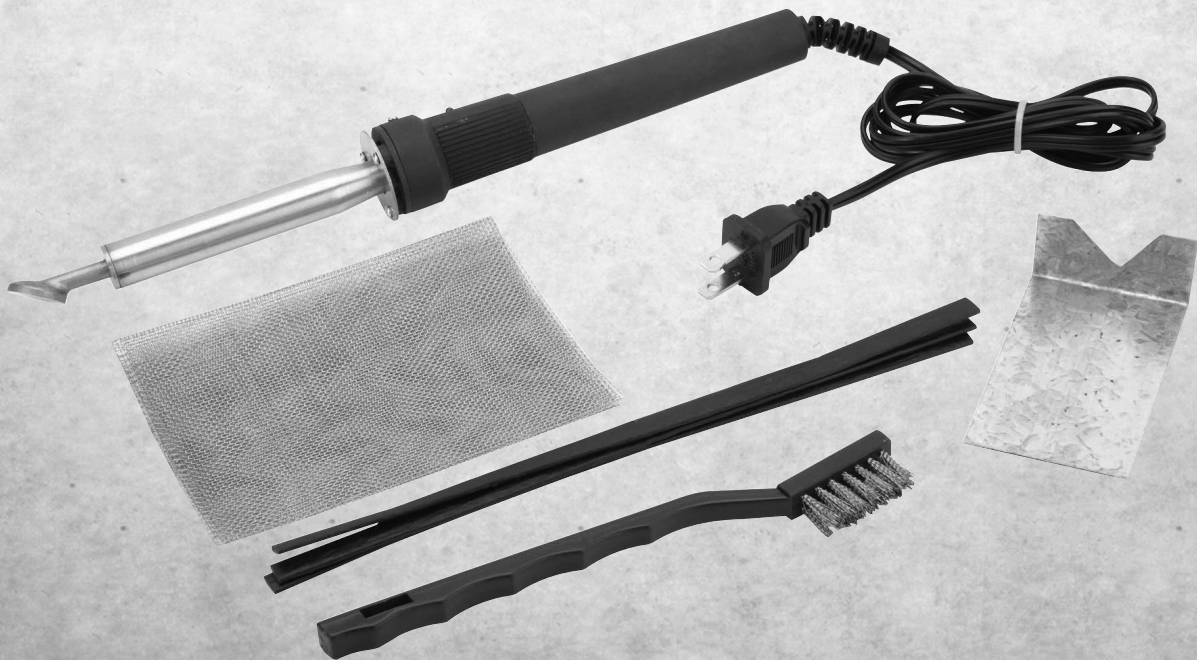

REV 12j

Visit our website at: <http://www.harborfreight.com>
Email our technical support at: tech@harborfreight.com

ITEM 60662

When unpacking, make sure that the product is intact and undamaged. If any parts are missing or broken, please call 1-800-444-3353 as soon as possible.

Copyright© 2008 by Harbor Freight Tools®. All rights reserved.
No portion of this manual or any artwork contained herein may be reproduced in any shape or form without the express written consent of Harbor Freight Tools. Diagrams within this manual may not be drawn proportionally. Due to continuing improvements, actual product may differ slightly from the product described herein. Tools required for assembly and service may not be included.

WARNING

**Read this material before using this product.
Failure to do so can result in serious injury.
SAVE THIS MANUAL.**

SAVE THIS MANUAL

Keep this manual for the safety warnings and precautions, assembly, operating, inspection, maintenance and cleaning procedures. Write the product's serial number in the back of the manual near the assembly diagram (or month and year of purchase if product has no number). Keep this manual and the receipt in a safe and dry place for future reference.

IMPORTANT SAFETY INFORMATION

In this manual, on the labeling, and all other information provided with this product:



This is the safety alert symbol. It is used to alert you to potential personal injury hazards. Obey all safety messages that follow this symbol to avoid possible injury or death.

DANGER

DANGER indicates a hazardous situation which, if not avoided, will result in death or serious injury.

WARNING

WARNING indicates a hazardous situation which, if not avoided, could result in death or serious injury.

CAUTION

CAUTION, used with the safety alert symbol, indicates a hazardous situation which, if not avoided, could result in minor or moderate injury.

NOTICE

NOTICE is used to address practices not related to personal injury.

CAUTION

CAUTION, without the safety alert symbol, is used to address practices not related to personal injury.

General Power Tool Safety Warnings



WARNING Read all safety warnings and instructions. Failure to follow the warnings and instructions may result in electric shock, fire and/or serious injury. Save all warnings and instructions for future reference. The term "power tool" in the warnings refers to your mains-operated (corded) power tool.

1. **Work area safety**
 - a. **Keep work area clean and well lit.** Cluttered or dark areas invite accidents.
 - b. **Do not operate power tools in explosive atmospheres, such as in the presence of flammable liquids, gases or dust.**
 - c. **Keep children and bystanders away while operating a power tool.** Distractions can cause you to lose control.
2. **Electrical safety**
 - a. **Power tool plugs must match the outlet. Never modify the plug in any way. Do not use any adapter plugs with grounded power tools.** Unmodified plugs and matching outlets will reduce risk of electric shock.

- b. **Avoid body contact with grounded surfaces such as pipes, radiators, ranges and refrigerators.** *There is an increased risk of electric shock if your body is grounded.*
 - c. **Do not expose power tools to rain or wet conditions.** *Water entering a power tool will increase the risk of electric shock.*
 - d. **Do not abuse the cord. Never use the cord for carrying, pulling or unplugging the power tool. Keep cord away from heat, oil, sharp edges or moving parts.** *Damaged or entangled cords increase the risk of electric shock.*
 - e. **When operating a power tool outdoors, use an extension cord suitable for outdoor use.** *Use of a cord suitable for outdoor use reduces the risk of electric shock.*
 - f. **If operating tool in a damp location is unavoidable, use a Ground Fault Circuit Interrupter (GFCI) protected supply.** *Use of a GFCI reduces the risk of electric shock.*
3. **Personal safety**
- a. **Stay alert, watch what you are doing and use common sense when operating a power tool. Do not use a power tool while you are tired or under the influence of drugs, alcohol or medication.** *A moment of inattention while operating power tools may result in serious personal injury.*
 - b. **Use safety equipment.** *Always wear ANSI-approved safety goggles, heavy-duty work gloves and face shield during use.*
 - c. **Do not overreach. Keep proper footing and balance at all times.** *This enables better control of the power tool in unexpected situations.*
4. **Power tool use and care**
- a. **Do not force tool. Use the correct tool for your application.** *The correct tool will do the job better and safer at the rate for which it was designed.*
 - b. **Disconnect the plug from the power source and/or the battery pack from the tool before making any adjustments, changing accessories, or storing power tools.** *Such preventive safety measures reduce the risk of starting the power tool accidentally.*
 - c. **Store idle tools out of the reach of children and do not allow persons unfamiliar with the tool or these instructions to operate the power tool.** *Welding tools are dangerous in the hands of untrained users.*
 - d. **Maintain welding tools. Check for misalignment or binding of moving parts, breakage of parts and any other condition that may affect the tool's operation. If damaged, have the tool repaired before use.** *Many accidents are caused by poorly maintained tools.*
 - e. **Keep cutting tools sharp and clean.** *Properly maintained cutting tools with sharp cutting edges are less likely to bind and are easier to control.*
 - f. **Use the tool and accessories in accordance with these instructions, taking into account the working conditions and the work to be performed.** *Use of the tool for operations different from those intended could result in a hazardous situation.*

5. **Service**

- a. **Have your tool serviced by a qualified repair person using only identical replacement parts.** *This will ensure that the safety of the tool is maintained.*

Welding Kit Safety Warnings

1. Do not use this Plastic Welding Kit near flammable materials.
2. Handle hot tip with care. Do not touch any metal parts on the Welder until they have completely cooled.
3. Use in well-ventilated areas only.
4. Do not place the Welder in a vise to change heating elements.
5. Always use Wire Brush (5) to clean the tip on the Welder.
6. Avoid electrical shock. Do not use in a damp or wet environment.
7. Never rest the Welder on a flammable surface.
8. Avoid unintentional starting. Prepare to begin work before plugging in tool.
9. Do not leave the tool unattended when it is plugged into an electrical outlet. Unplug it from its electrical outlet and allow it to cool before leaving.
10. Use clamps (not included) or other practical ways to secure and support the workpiece to a stable platform. Holding the work by hand or against your body is unstable and may lead to loss of control.
11. This product is not a toy. Keep it out of reach of children.
12. This product is designed for use only for **plastic** welding. This product is designed to be used only to weld plastic items.
13. When working with plastics, varnish, or similar materials, gases develop that are easily flammable and can lead to explosions. Be prepared for flames to develop and keep suitable fire extinguishing means at hand.
14. Do not point Welder at people or animals. The intense heat can injure them.
15. Maintain labels and nameplates on the tool. These carry important safety information. If unreadable or missing, contact Harbor Freight Tools for a replacement.
16. People with pacemakers should consult their physician(s) before use. Electromagnetic fields in close proximity to heart pacemaker could cause pacemaker interference or pacemaker failure. In addition, people with pacemakers should:
 - Avoid operating alone.
 - Properly maintain and inspect to avoid electrical shock.
 - Any power cord must be properly grounded. Ground Fault Circuit Interrupter (GFCI) should also be implemented – it prevents sustained electrical shock.
17. Some dust created by power sanding, sawing, grinding, drilling, and other construction activities, contains chemicals known [to the State of California] to cause cancer, birth defects or other reproductive harm. Some examples of these chemicals are:
 - Lead from lead-based paints
 - Crystalline silica from bricks and cement or other masonry products
 - Arsenic and chromium from chemically treated lumber

Your risk from these exposures varies, depending on how often you do this type of work. To reduce your exposure to these chemicals: work in a well ventilated area, and work with approved safety equipment, such as those dust masks that are specially designed to filter out microscopic particles. (California Health & Safety Code § 25249.5, *et seq.*)

- The warnings, precautions, and instructions discussed in this instruction manual cannot cover all possible conditions and situations that may occur. It must be understood by the operator that common sense and caution are factors which cannot be built into this product, but must be supplied by the operator.



SAVE THESE INSTRUCTIONS.

GROUNDING

WARNING

TO PREVENT ELECTRIC SHOCK



AND DEATH FROM INCORRECT GROUNDING WIRE CONNECTION: Check with a qualified electrician if you are in doubt as to whether the outlet is properly grounded. Do not modify plug provided with tool. Never remove grounding prong from plug. Do not use tool if power cord or plug is damaged. If damaged, have it repaired by a service facility before use. If plug will not fit outlet, have a proper outlet installed by a qualified electrician.

Double Insulated Tools: Tools with Two Prong Plugs

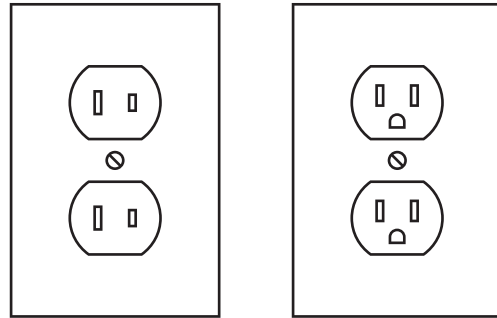

Outlets for 2-Prong Plug





- Tools marked “Double Insulated” do not require grounding. They have a special double insulation system which satisfies OSHA requirements and complies with the applicable standards of Underwriters Laboratories, Inc., the Canadian Standard Association, and the National Electrical Code.
- Double insulated tools may be used in either of the 120 volt outlets shown in the preceding illustration. (See “Outlets for 2-Prong Plug”.)

Extension Cords

- Grounded** tools require a three wire extension cord. **Double Insulated** tools can use either a two or three wire extension cord.
- As distance from supply outlet increases, use a heavier gauge extension cord. Using extension cords with inadequately sized wire causes a drop in voltage, resulting in loss of power and possible tool damage. The smaller the gauge number of wire, the greater capacity of cord. For example, a 14 gauge cord can carry a higher current than a 16 gauge cord. (See Table A.)

3. When using more than one extension cord to make up the total length, make sure each cord contains at least the minimum wire size required. **(See Table A.)**
4. If using extension cord for more than one tool, add nameplate amperes and use sum to determine required minimum cord size. **(See Table A.)**
5. If using extension cord outdoors, make sure it is marked with “W-A” (“W” in Canada) to indicate it is acceptable for outdoor use.
6. Make sure extension cord is properly wired and in good electrical condition. Always replace damaged extension cord or have it repaired by a qualified electrician before using it.
7. Protect extension cords from sharp objects, high heat, and wet areas.

Symbology

	Canadian Standards Association
	Underwriters Laboratories, Inc.
	Volts Alternating Current
	Amperes
n_0 xxxx/min.	No Load Revolutions per Minute (RPM)

RECOMMENDED MINIMUM WIRE GAUGE FOR EXTENSION CORDS* (120/240 VOLT)					
NAMEPLATE AMPERES (at full load)	EXTENSION CORD LENGTH				
	25'	50'	75'	100'	150'
0 – 2.0	18	18	18	18	16
2.1 – 3.4	18	18	18	16	14
3.5 – 5.0	18	18	16	14	12
5.1 – 7.0	18	16	14	12	12
7.1 – 12.0	18	14	12	10	-
12.1 – 16.0	14	12	10	-	-
16.1 – 20.0	12	10	-	-	-

TABLE A * Based on limiting the line voltage drop to five volts at 150% of the rated amperes.

Symbology

	Double Insulated
---	------------------

SPECIFICATIONS

Electrical Requirements	120 V~ / 60 Hz
Max. Temperature	525° F
Power Cord	18-AWG x 2C

UNPACKING

When unpacking, check to make sure that the item is intact and undamaged. If any parts are missing or broken, please call Harbor Freight Tools at 1-800-444-3353 as soon as possible.

OPERATING INSTRUCTIONS



Read the **ENTIRE IMPORTANT SAFETY INFORMATION** section at the beginning of this manual including all text under subheadings therein before set up or use of this product.

Tool Set Up



TO PREVENT SERIOUS INJURY

FROM ACCIDENTAL OPERATION: Unplug the tool from its electrical outlet and allow it to cool before performing any inspection, maintenance, or cleaning procedures.

Work Piece and Work Area Set Up

1. Designate a work area that is clean and well-lit. The work area must not allow access by children or pets to prevent distraction and injury.
2. Route the power cord along a safe path to reach the work area without creating a tripping hazard or exposing

the power cord to possible damage. The power cord must reach the work area with enough extra length to allow free movement while working.

3. Secure loose workpieces using a vise or clamps (not included) to prevent movement while working.
4. There must not be hazardous objects, such as utility lines or foreign objects, nearby that will present a hazard while working.

General Operating Instructions

1. **Note:** It is recommended that you first practice this procedure on scrap material.
2. Plug the Power Cord (6) of the tool into a 120 volt, grounded, electrical outlet.
3. Allow Welder (1) to pre-heat for 5 to 10 minutes before use. Prep the surface by sanding off excess paint, or, if necessary, grinding surface to add texture.
4. To connect sections of non-flexible plastic or to repair or fill-in cracks, apply the Welder's tip to the end of a Repair Stick (2) and melt the Stick onto the work surface.
5. Melt and spread the Repair Stick over cracked or damaged area. Use edge of welding tip to melt off any excess plastic.
6. **WARNING!** Be careful to not melt base material area during use.
7. Once the melted area cools (apply cold water to speed up cooling), sand surface with 80-grit sandpaper (not included).

8. To repair flexible plastic tabs or any plastic that requires elasticity, sand area with 25-40 grit sandpaper.
9. Cut an appropriate-sized piece of the Reinforcing Mesh (3). Once the Welder is heated, fit mesh piece into corner of tab. Applying the mesh will reinforce the plastic tab.
10. Lightly scuff melted mesh with sandpaper.
11. Melt appropriate-sized piece of Plastic Stick into Mesh and use Welder to spread plastic into cracks and damaged area. Doing so will help strengthen plastic.
12. To repair damaged plastic bolt hole or slot, use sandpaper to taper and smooth broken edges. Apply aluminum tape (not included) to surrounding surface if desired.
13. Melt Mesh into plastic gap, refilling edge around hole or slot. Apply melted plastic to Mesh and allow to cool.
14. Remove aluminum tape from hole and, if necessary, re-drill hole and smooth with 80-grit sandpaper.
15. When welding is finished, unplug the Power Cord and set the Welder onto the Welder Stand (4) and allow to cool down.
16. Once cool, clean off welding tip using the Wire Brush (5) and then store Kit indoors out of children's reach.

MAINTENANCE AND SERVICING



Procedures not specifically explained in this manual must be performed only by a qualified technician.

⚠️ WARNING

TO PREVENT SERIOUS INJURY

FROM ACCIDENTAL OPERATION: Unplug the tool from its electrical outlet and allow to cool before performing any inspection, maintenance, or cleaning procedures.

TO PREVENT SERIOUS INJURY FROM TOOL FAILURE: Do not use damaged equipment. If abnormal noise or vibration occurs, have the problem corrected before further use.

Cleaning, Maintenance, and Lubrication

1. **BEFORE EACH USE**, inspect the general condition of the tool. Check for loose screws, cracked or broken parts, damaged electrical wiring, and any other condition that may affect its safe operation.
2. **AFTER USE**, clean external surfaces of the tool with clean cloth.
3. **⚠️ WARNING!** If the supply cord of this power tool is damaged, it must be replaced only by a qualified service technician.
4. Always store Welding Kit in a clean, dry and safe location away from children.

PARTS LIST & DIAGRAM

Part	Description	Qty.
1	Welder	1
2	Repair Sticks	20
3	Reinforcing Mesh	1

Part	Description	Qty.
4	Welder Stand	1
5	Wire Brush	1
6	Power Cord	1

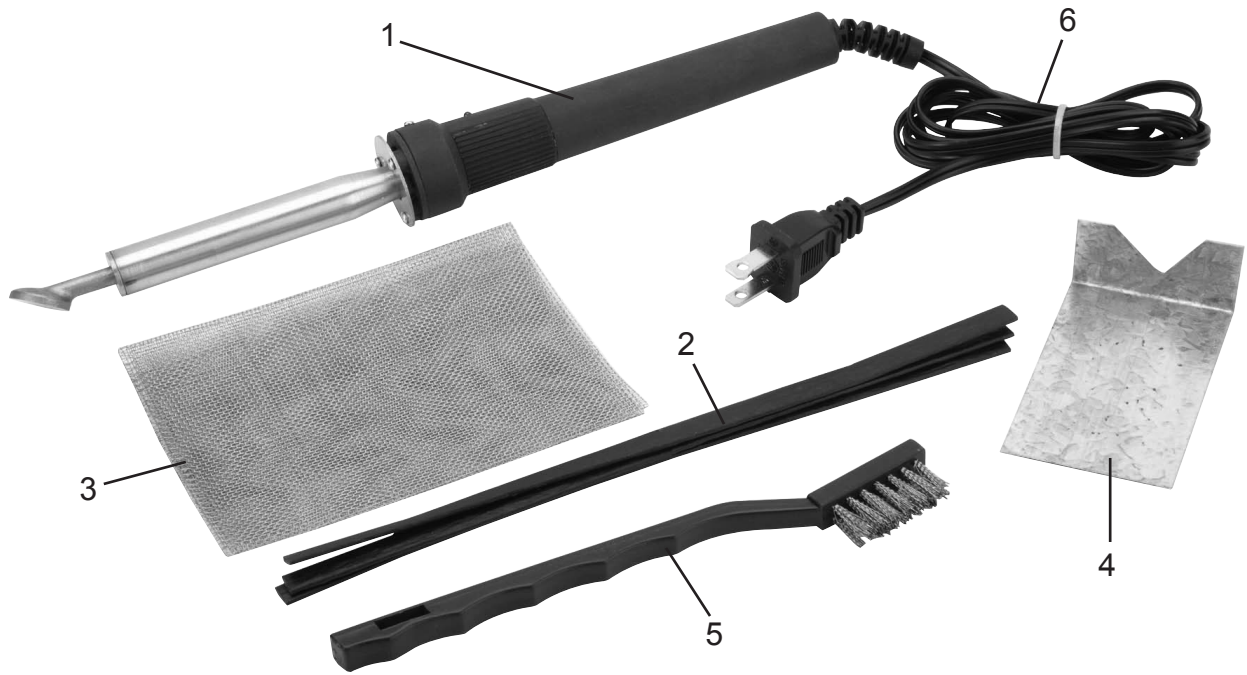

PLEASE READ THE FOLLOWING CAREFULLY

THE MANUFACTURER AND/OR DISTRIBUTOR HAS PROVIDED THE PARTS LIST AND ASSEMBLY DIAGRAM IN THIS MANUAL AS A REFERENCE TOOL ONLY. NEITHER THE MANUFACTURER OR DISTRIBUTOR MAKES ANY REPRESENTATION OR WARRANTY OF ANY KIND TO THE BUYER THAT HE OR SHE IS QUALIFIED TO MAKE ANY REPAIRS TO THE PRODUCT, OR THAT HE OR SHE IS QUALIFIED TO REPLACE ANY PARTS OF THE PRODUCT. IN FACT, THE MANUFACTURER AND/OR DISTRIBUTOR EXPRESSLY STATES THAT ALL REPAIRS AND PARTS REPLACEMENTS SHOULD BE UNDERTAKEN BY CERTIFIED AND LICENSED TECHNICIANS, AND NOT BY THE BUYER. THE BUYER ASSUMES ALL RISK AND LIABILITY ARISING OUT OF HIS OR HER REPAIRS TO THE ORIGINAL PRODUCT OR REPLACEMENT PARTS THERETO, OR ARISING OUT OF HIS OR HER INSTALLATION OF REPLACEMENT PARTS THERETO.

Record Product's Serial Number Here:

Note: If product has no serial number, record month and year of purchase instead.

Note: Some parts are listed and shown for illustration purposes only, and are not available individually as replacement parts.

Limited 90 Day Warranty

Harbor Freight Tools Co. makes every effort to assure that its products meet high quality and durability standards, and warrants to the original purchaser that this product is free from defects in materials and workmanship for the period of 90 days from the date of purchase. This warranty does not apply to damage due directly or indirectly, to misuse, abuse, negligence or accidents, repairs or alterations outside our facilities, criminal activity, improper installation, normal wear and tear, or to lack of maintenance. We shall in no event be liable for death, injuries to persons or property, or for incidental, contingent, special or consequential damages arising from the use of our product. Some states do not allow the exclusion or limitation of incidental or consequential damages, so the above limitation of exclusion may not apply to you. THIS WARRANTY IS EXPRESSLY IN LIEU OF ALL OTHER WARRANTIES, EXPRESS OR IMPLIED, INCLUDING THE WARRANTIES OF MERCHANTABILITY AND FITNESS.

To take advantage of this warranty, the product or part must be returned to us with transportation charges prepaid. Proof of purchase date and an explanation of the complaint must accompany the merchandise. If our inspection verifies the defect, we will either repair or replace the product at our election or we may elect to refund the purchase price if we cannot readily and quickly provide you with a replacement. We will return repaired products at our expense, but if we determine there is no defect, or that the defect resulted from causes not within the scope of our warranty, then you must bear the cost of returning the product.

This warranty gives you specific legal rights and you may also have other rights which vary from state to state.



3491 Mission Oaks Blvd. • PO Box 6009 • Camarillo, CA 93011 • (800) 444-3353