

Owner's Manual & Safety Instructions

Save This Manual Keep this manual for the safety warnings and precautions, assembly, operating, inspection, maintenance and cleaning procedures. Write the product's serial number in the back of the manual near the assembly diagram (or month and year of purchase if product has no number). Keep this manual and the receipt in a safe and dry place for future reference.

24d

HAULMASTER

1/2 TON CAPACITY PICKUP TRUCK CRANE



Vehicle Not Included

Visit our website at: <http://www.harborfreight.com>
Email our technical support at: productsupport@harborfreight.com

60732

When unpacking, make sure that the product is intact and undamaged. If any parts are missing or broken, please call 1-888-866-5797 as soon as possible.

Copyright© 2023 by Harbor Freight Tools®. All rights reserved.
No portion of this manual or any artwork contained herein may be reproduced in any shape or form without the express written consent of Harbor Freight Tools. Diagrams within this manual may not be drawn proportionally. Due to continuing improvements, actual product may differ slightly from the product described herein.
Tools required for assembly and service may not be included.

⚠WARNING

Read this material before using this product.
Failure to do so can result in serious injury.
SAVE THIS MANUAL.

Table of Contents

Safety	2	Maintenance	8
Specifications	3	Parts List and Diagram	10
Assembly	4	Warranty	12
Operation	6		



WARNING SYMBOLS AND DEFINITIONS

	This is the safety alert symbol. It is used to alert you to potential personal injury hazards. Obey all safety messages that follow this symbol to avoid possible injury or death.
	Indicates a hazardous situation which, if not avoided, will result in death or serious injury.
	Indicates a hazardous situation which, if not avoided, could result in death or serious injury.
	Indicates a hazardous situation which, if not avoided, could result in minor or moderate injury.
	Addresses practices not related to personal injury.

IMPORTANT SAFETY INFORMATION

WARNING

Read all safety warnings and instructions.
Failure to follow the warnings and instructions may result in serious injury.
Save all warnings and instructions for future reference.

General Safety Warnings

- Study, understand, and follow all instructions before installing or operating this device.
- Attach to frame of truck bed according to manual instructions only. Verify that installation surface has no hidden components or brake lines before drilling or driving screws.
- Engage parking brake before use. Do not move vehicle with load attached to Crane.
- Do not exceed rated capacity.
- Use only slings or chains with a rated capacity greater than the weight of the load being lifted.
- Do not allow load to swing or drop violently while lowering or moving.
- No alterations shall be made to this product. Do not adjust safety valve.
- Keep clear from underneath suspended load. Do not lift people or lift load over people.
- Capacity decreases as boom lengthens. Follow capacities marked on boom.
- Replacement ram must have same rating, mounting points, and maximum length.
- Wear ANSI-approved safety goggles, heavy-duty work gloves, and steel-toed work boots during installation and use.
- Do not use for aircraft purposes.
- Inspect before every use; do not use if parts loose or damaged.
- Before driving vehicle, lower boom and position over truck's wheel well, then insert Large Lock Pin to prevent boom from swiveling.

15. Attach load to Hook securely by properly rated, suitable means, such as chains, shackles, hooks, lifting slings, etc. Load must be attached to prevent accidental disconnection.
16. Properly seat sling or other device in Hook and fully close Hook's safety clasp. Do not allow Hook hitch to support any part of load. Do not apply load to the point of the Hook.
17. Stay alert. Watch what you are doing, and use common sense when operating Crane.
18. Do not use Crane while tired or under the influence of drugs, alcohol, or medication. A moment of inattention may result in serious personal injury.
19. Keep children and bystanders away while operating the Crane. Distractions can cause you to lose control.
20. Have Crane serviced by a qualified repair person using only identical replacement parts. This will ensure that the safety of the Crane is maintained.
21. Maintain labels and nameplates. These carry important information. If unreadable or missing, contact Harbor Freight Tools for a replacement.
22. The warnings, precautions, and instructions discussed in this manual cannot cover all possible conditions and situations that may occur. The operator must understand that common sense and caution are factors, which cannot be built into this product, but must be supplied by the operator.

Ram Safety Warnings

1. Attach securely to Crane before use.
2. Do not exceed rated capacity.
3. Do not adjust safety valve.
4. Keep clear of load while lifting and lowering.
5. Lower load slowly.
6. Be aware of dynamic loading! Sudden load movement may briefly create excess load causing product failure.



SAVE THESE INSTRUCTIONS.

Specifications

Rated Capacity	1,000 lb.
Boom Length, Max.	53-1/2"
Boom Length, Min.	33-3/8"
Chain	7-1/2" L, 3/8" Diameter
Hook Opening	3/4"

Assembly Instructions



Read **ENTIRE IMPORTANT SAFETY INFORMATION** section at beginning of this manual including all text under subheadings therein before set up or use of this product.

1. Locate a mounting position so the Crane will be near end of truck bed and can be attached to frame.
4. Slide Post (13) onto Base (18) and secure using Large Lock Pin (1). (See Figure B.)

WARNING! The Base must be securely bolted to the **frame** of the truck bed. Bolting the Base to the truck bed will not provide necessary support and could result in product failure and serious bodily injury.

Note: Verify that installation surface has no hidden components or brake lines before drilling or driving screws.

2. Use the Base to mark drilling holes. Drill holes.
3. Mount Base to frame using Nuts (5), Spring Washers (12), Washers (10), Mounting Plates (17) and Bolts (11). (See Figure A.)

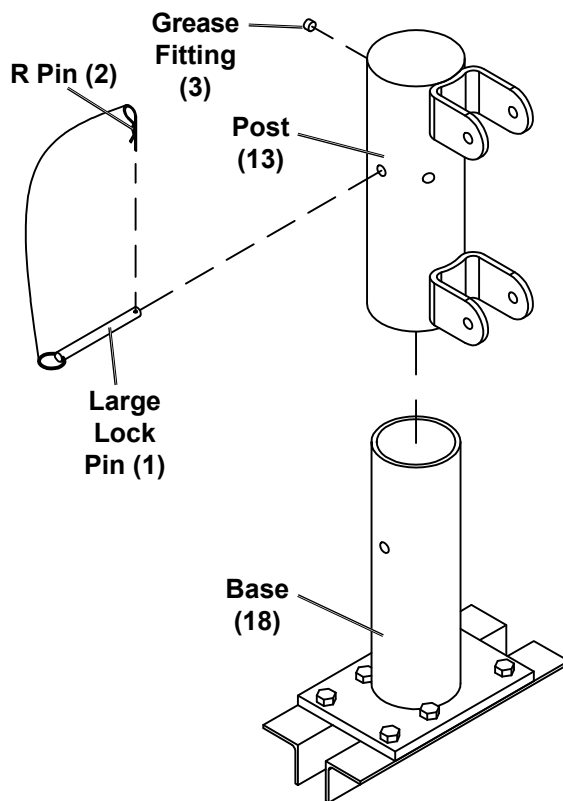
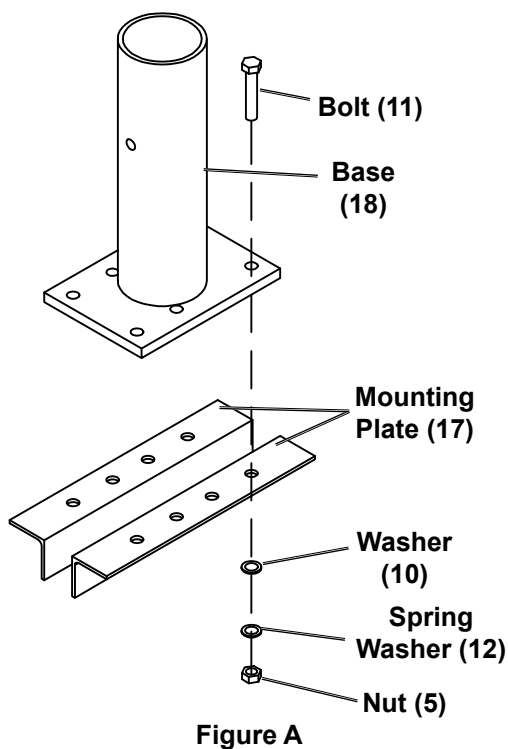

Figure B

5. Attach Ram (19) to Lower Post Bracket using Bolt (20), Washer (10), Spring Washer (12) and Nut (5). (See Figure C.)

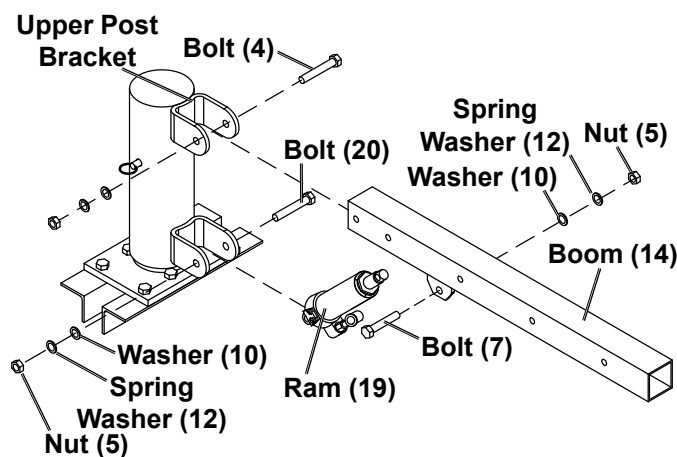

Figure C

6. Attach Boom (14), Bracket facing down, to Upper Post Bracket using Bolt (4), Spring Washer (12) Washer (10) and Nut (5).
7. Connect Boom Bracket to Ram using Bolt (7), Spring Washer (12), Washer, (10), and Nut (5).
8. Slide Boom Extension (15) into Boom so that Oval Hole is facing down. Secure with Small Lock Pin (8). (See Figure D.)
9. Connect Hook and Chain (9) to Boom Extension by putting end link through Oval Hole and securing with Bolt (6), Spring Washer (12), Washer (10) and Nut (5).
10. Thread Grease Fitting (3) into Post.

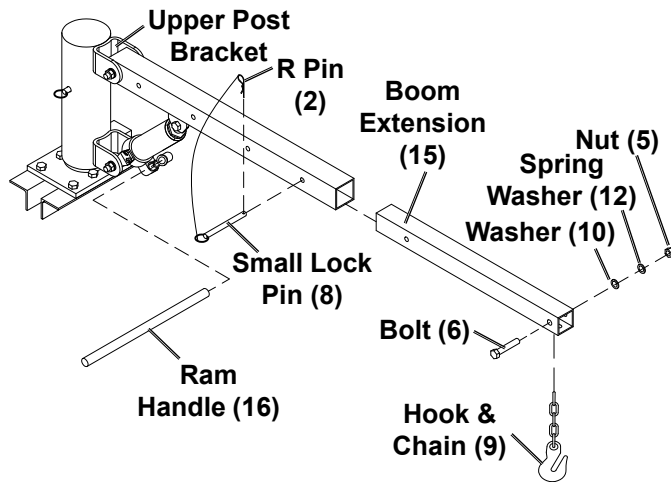

Figure D

Operating Instructions



Read **ENTIRE IMPORTANT SAFETY INFORMATION** section at beginning of this manual including all text under subheadings therein before set up or use of this product.

Note: Once Assembly is complete, tighten ALL Bolts before initial operation.

Bleeding Instructions

IMPORTANT! Before first use, check for proper hydraulic oil level and thoroughly test the Crane. If it does not work properly, bleed air from its hydraulic system as follows:

1. Remove Oil Fill Plug. Fill with hydraulic oil (sold separately) to full level, if necessary.
2. Open Release Valve by turning counterclockwise with Ram Handle.
3. Insert Ram Handle into Fulcrum, apply downward pressure to Boom, then pump Handle quickly several times.
4. Check oil level and, if necessary, top off with hydraulic oil.
5. Close Release Valve and replace Oil Fill Plug.
6. Test Crane several times for proper operation before attempting to lift a load.
7. If, after bleeding, the Crane still does not appear to be working properly, do not use until repaired by a qualified service technician.

Operating the Crane

WARNING! The Boom Extension has four positions. Each position has a weight capacity marked on the Boom. Do not lift more than rated capacity. Be aware of dynamic loading! Sudden load movement may briefly create excess load causing product failure and serious bodily injury.

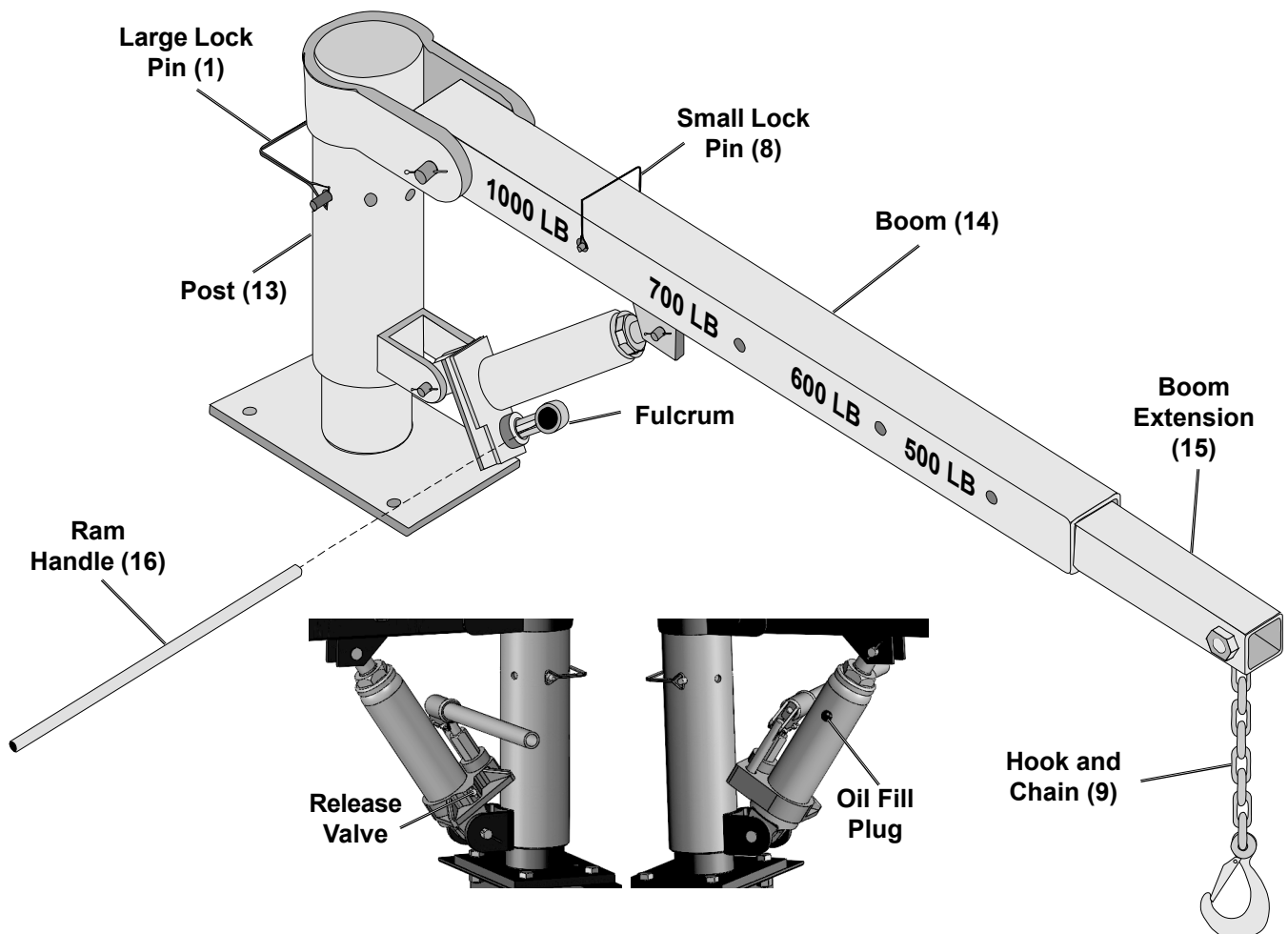

Figure E

Loading

WARNING! TO PREVENT SERIOUS INJURY:

Engage parking brake before use. Do not move vehicle with load attached to Crane.

1. Remove Large Lock Pin and swivel Boom so Hook is over load. If necessary, remove Small Lock Pin, adjust Boom Extension, then replace Small Lock Pin.

WARNING! TO PREVENT SERIOUS INJURY: Do not attempt to extend or retract Boom while load is attached.

2. Make sure Boom will handle load when it is extended. (See Figure F.)

Capacity (lb.)	Boom Length
500	53-1/2"
600	47-1/2"
700	41-1/2"
1,000	33-3/8"

Figure F

3. Lower Boom until Hook can be attached to load.

Unloading

WARNING! TO PREVENT SERIOUS INJURY:

Engage parking brake before use. Do not move vehicle with load attached to Crane.

1. Remove Large Lock Pin.
2. Swivel and lift Boom so Hook is over load. If necessary, remove Small Lock Pin, adjust Boom Extension, then replace Small Lock Pin.

WARNING! TO PREVENT SERIOUS INJURY: Do not attempt to extend or retract Boom while load is attached.

3. Make sure Boom will handle load when it is extended. (See Figure G.)

Capacity (lb.)	Boom Length
500	53-1/2"
600	47-1/2"
700	41-1/2"
1,000	33-3/8"

Figure G

4. Attach Hook to properly secured load, giving specific attention to load balancing.
5. Before lifting load, make sure chain is not kinked or twisted.
6. **To lift load:**
 - a. Make sure Release Valve is closed by turning clockwise with Ram Handle.
 - b. Pump Ram Handle until load has been lifted high enough to clear truck bed.
7. **To move load:** Swivel Boom until the load is directly over the truck bed.
8. **To lower load:** **Slowly** open Release Valve by turning counterclockwise with Ram Handle.
9. Remove Hook only after load has been lowered completely.
10. Before driving vehicle, lower Boom and position over truck's wheel well, then insert Large Lock Pin to prevent Boom from swiveling.

4. Attach Hook to properly secured load, giving specific attention to load balancing.
5. Before lifting load, make sure chain is not kinked or twisted.
6. **To lift load:**
 - a. Make sure Release Valve is closed by turning clockwise with Ram Handle.
 - b. Pump Ram Handle until load has raised high enough to just clear truck bed.
7. **To move load:** Swivel Boom until load is safely away from truck bed and over a level, flat surface.
8. **To lower load:** **Slowly** open Release Valve by turning counterclockwise with Ram Handle.
9. Before driving vehicle, lower Boom and position over truck's wheel well, then insert Large Lock Pin to prevent Boom from swiveling.

Maintenance and Servicing



Procedures not specifically explained in this manual must be performed only by a qualified technician.

WARNING

TO PREVENT SERIOUS INJURY FROM ACCIDENTAL OPERATION:
Do not use damaged equipment. If abnormal noise or vibration occurs, have the problem corrected before further use.

Cleaning, Maintenance, and Lubrication

1. **BEFORE EACH USE**, inspect the general condition of the tool. Check for:
 - loose hardware,
 - misalignment or binding of moving parts,
 - cracked or broken parts,
 - proper Ram operation, and
 - any other condition that may affect its safe operation.
2. Lubricate the Grease Fitting with a grease gun once a month, or when the Boom becomes difficult to swivel on the Post.

Note: If Crane will be exposed to wet conditions, more frequent lubrication may be necessary to prevent buildup of rust.
3. Change the hydraulic oil at least once every year:
 - a. Remove Ram from Crane. Lower ram completely.
 - b. Remove Oil Fill Plug.
 - c. Tip Ram to allow old hydraulic oil to completely drain out.
 - d. Dispose of old hydraulic oil in accordance with local regulations.
 - e. With the Ram upright, fill with hydraulic oil (sold separately) to full level.
 - f. Open Valve Release Screw and pump the Handle to bleed air from the system (see Bleeding Instructions on pg. 6).
 - g. Reinstall Oil Fill Plug.
 - h. Reinstall Ram to Crane.
4. Top assembly may be removed and stored indoors in a dry, safe place out of the reach of children.

Troubleshooting

⚠ WARNING TO PREVENT SERIOUS INJURY: Use caution when troubleshooting malfunctioning Crane. Stay clear of supported load. Completely resolve all problems before use.

If solutions presented in Troubleshooting guide do not solve the problem, have a qualified technician inspect and repair Crane before use. **After Crane is repaired: Test it carefully without a load by raising and lowering it fully, checking for proper operation, BEFORE RETURNING CRANE TO OPERATION.**

DO NOT USE A DAMAGED OR MALFUNCTIONING CRANE!

POSSIBLE SYMPTOMS						PROBABLE SOLUTION (Make certain that the Crane is not supporting a load while attempting a solution.)
Ram will not lift at its weight capacity	Hook lowers under load	Pump stroke feels spongy	Hook will not lift all the way	Handle moves up when Ram is under load	Oil leaking from Fill Plug	
X	X					Check that Release Valve is closed fully. Bleed air from the system.
X	X			X		Valve may be blocked and may not close fully. To flush the valve: 1. Lower the Boom and securely close the Release Valve. 2. Manually lift the Boom several inches. 3. Open the Release Valve and force the Boom down as quickly as possible.
X		X	X			Ram may be low on oil. Check the oil level and refill if needed. Ram may require bleeding - see Bleeding Instructions on page 6.
					X	Unit may have too much hydraulic oil inside; check fluid level and adjust if needed.

PLEASE READ THE FOLLOWING CAREFULLY

THE MANUFACTURER AND/OR DISTRIBUTOR HAS PROVIDED THE PARTS LIST AND ASSEMBLY DIAGRAM IN THIS MANUAL AS A REFERENCE TOOL ONLY. NEITHER THE MANUFACTURER OR DISTRIBUTOR MAKES ANY REPRESENTATION OR WARRANTY OF ANY KIND TO THE BUYER THAT HE OR SHE IS QUALIFIED TO MAKE ANY REPAIRS TO THE PRODUCT, OR THAT HE OR SHE IS QUALIFIED TO REPLACE ANY PARTS OF THE PRODUCT. IN FACT, THE MANUFACTURER AND/OR DISTRIBUTOR EXPRESSLY STATES THAT ALL REPAIRS AND PARTS REPLACEMENTS SHOULD BE UNDERTAKEN BY CERTIFIED AND LICENSED TECHNICIANS, AND NOT BY THE BUYER. THE BUYER ASSUMES ALL RISK AND LIABILITY ARISING OUT OF HIS OR HER REPAIRS TO THE ORIGINAL PRODUCT OR REPLACEMENT PARTS THERETO, OR ARISING OUT OF HIS OR HER INSTALLATION OF REPLACEMENT PARTS THERETO.

Parts List

Part	Description	Qty
1	Large Lock Pin	1
2	R Pin	2
3	Grease Fitting	1
4	Bolt, M12x100	1
5	Nut M12	10
6	Bolt, M12x70	1
7	Bolt, M12x60	1
8	Small Lock Pin	1
9	Hook & Chain	1
10	Washer 12	10

Part	Description	Qty
11	Bolt, M12x50	6
12	Spring Washer 12	10
13	Post	1
14	Boom	1
15	Boom Extension	1
16	Ram Handle	1
17	Mounting Plate	2
18	Base	1
19	Ram	1
20	Bolt, M12x90	1

Record Product's Serial Number Here: _____

Note: If product has no serial number, record month and year of purchase instead.

Note: Some parts are listed and shown for illustration purposes only, and are not available individually as replacement parts. Specify UPC 193175485632 when ordering parts.

Assembly Diagram

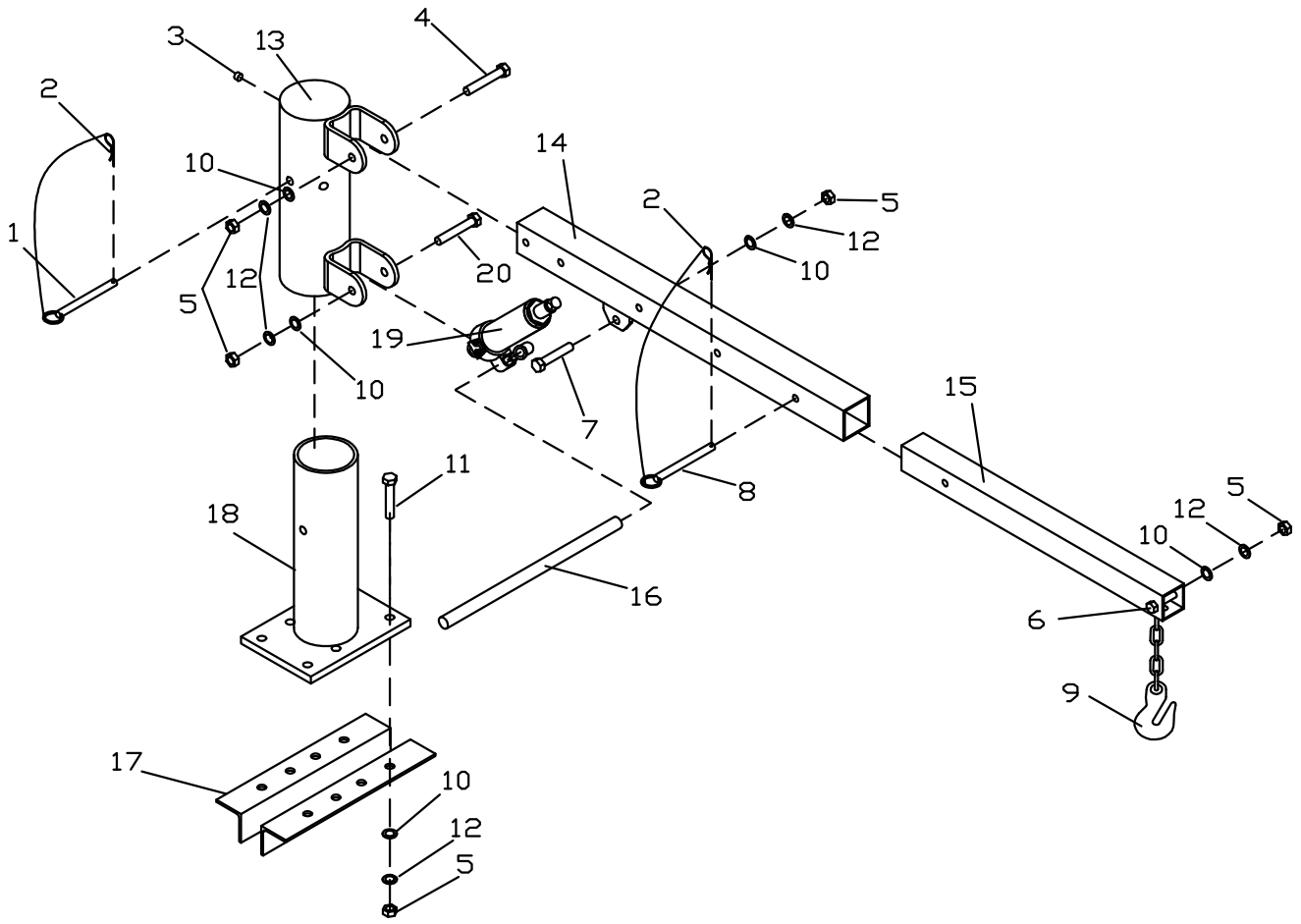

SAFETY

SETUP

OPERATION

MAINTENANCE

Limited 90 Day Warranty

Harbor Freight Tools Co. makes every effort to assure that its products meet high quality and durability standards, and warrants to the original purchaser that this product is free from defects in materials and workmanship for the period of 90 days from the date of purchase. This warranty does not apply to damage due directly or indirectly, to misuse, abuse, negligence or accidents, repairs or alterations outside our facilities, criminal activity, improper installation, normal wear and tear, or to lack of maintenance. We shall in no event be liable for death, injuries to persons or property, or for incidental, contingent, special or consequential damages arising from the use of our product. Some states do not allow the exclusion or limitation of incidental or consequential damages, so the above limitation of exclusion may not apply to you. THIS WARRANTY IS EXPRESSLY IN LIEU OF ALL OTHER WARRANTIES, EXPRESS OR IMPLIED, INCLUDING THE WARRANTIES OF MERCHANTABILITY AND FITNESS.

To take advantage of this warranty, the product or part must be returned to us with transportation charges prepaid. Proof of purchase date and an explanation of the complaint must accompany the merchandise. If our inspection verifies the defect, we will either repair or replace the product at our election or we may elect to refund the purchase price if we cannot readily and quickly provide you with a replacement. We will return repaired products at our expense, but if we determine there is no defect, or that the defect resulted from causes not within the scope of our warranty, then you must bear the cost of returning the product.

This warranty gives you specific legal rights and you may also have other rights which vary from state to state.

The logo for Haulmaster, featuring the word "HAULMASTER" in a bold, italicized, sans-serif font. The letters are white with a thick black outline, and the entire word is set against a black background.

26677 Agoura Road • Calabasas, CA 91302 • 1-888-866-5797