

Owner's Manual & Safety Instructions

Save This Manual Keep this manual for the safety warnings and precautions, assembly, operating, inspection, maintenance and cleaning procedures. Write the product's serial number in the back of the manual near the assembly diagram (or month and year of purchase if product has no number). Keep this manual and the receipt in a safe and dry place for future reference.

22i

PITTSBURGH[®] AUTOMOTIVE

61600

2 TON UNDERHOIST SAFETY STAND



Visit our website at: <http://www.harborfreight.com>
Email our technical support at: productsupport@harborfreight.com

When unpacking, make sure that the product is intact and undamaged. If any parts are missing or broken, please call 1-888-866-5797 as soon as possible.

⚠ WARNING

Read this material before using this product. Failure to do so can result in serious injury. **SAVE THIS MANUAL.**

Copyright© 2022 by Harbor Freight Tools®. All rights reserved.
No portion of this manual or any artwork contained herein may be reproduced in any shape or form without the express written consent of Harbor Freight Tools. Diagrams within this manual may not be drawn proportionally. Due to continuing improvements, actual product may differ slightly from the product described herein. Tools required for assembly and service may not be included.

Specifications

Rated Capacity	4,000 lb.
Height Range	49" to 92-1/2"

IMPORTANT SAFETY INFORMATION

1. Study, understand, and follow all instructions before operating this device.
2. Do not exceed rated capacity.
3. Use only on hard level surface.
4. Do not use the stand to support a vehicle.
5. Center load on saddle.
6. Use stands in pairs to stabilize the vehicle before starting repairs.
7. Failure to heed these markings may result in personal injury and/ or property damage.
8. **NO ALTERATIONS SHALL BE MADE TO THIS PRODUCT.**
9. Wear ANSI-approved safety goggles and heavy-duty work gloves during assembly and use.
10. Use as intended only. This Stand is designed to help prevent the tipping/rocking of a vehicle while the vehicle is engaged on an automotive lift.
11. Do not use for aircraft purposes.
12. Inspect before every use; do not use if parts are loose or damaged.
13. **Be aware of dynamic loading!** Sudden load movement may briefly create excess load causing product failure.
14. Assemble only according to these instructions. Improper assembly can create hazards.
15. Keep assembly area clean and well lit.
16. Keep bystanders out of the area during assembly.
17. Do not assemble when tired or when under the influence of alcohol, drugs or medication.
18. Weight capacity and other product capabilities apply to properly and completely assembled product only.
19. Make sure the vehicle lift is rated to at least vehicle's weight, in good working order, and securely locked into place before using stand.
20. This product is not a toy. Do not allow children to play with or near this item.
21. Maintain product labels and nameplates. These carry important safety information. If unreadable or missing, contact Harbor Freight Tools for a replacement.

Assembly Instructions



Read the **ENTIRE IMPORTANT SAFETY INFORMATION** section at the beginning of this document including all text under subheadings therein before set up or use of this product.

Note: This product is assembled using fifteen 20mm long Bolts (12) and three 25mm long Bolts (6). Set the three longer Bolts aside before assembly for use in step 12 on page 4. Unless otherwise explained, assemble parts using Bolts (12), Washers (14), and Nuts (13).

**** Note:** For Steps 1-11, leave the Bolts (12) and Nuts (13) slightly loose to aid in assembly and alignment of the other Legs (8), Braces (9,16), etc.

1. Turn one Leg (8) so that the closed end with a hole faces up.
2. Attach Upper Braces (16) to the two holes midway up the Leg (8).**
3. Attach Lower Braces (9) to the two lower holes on the Leg (8).**

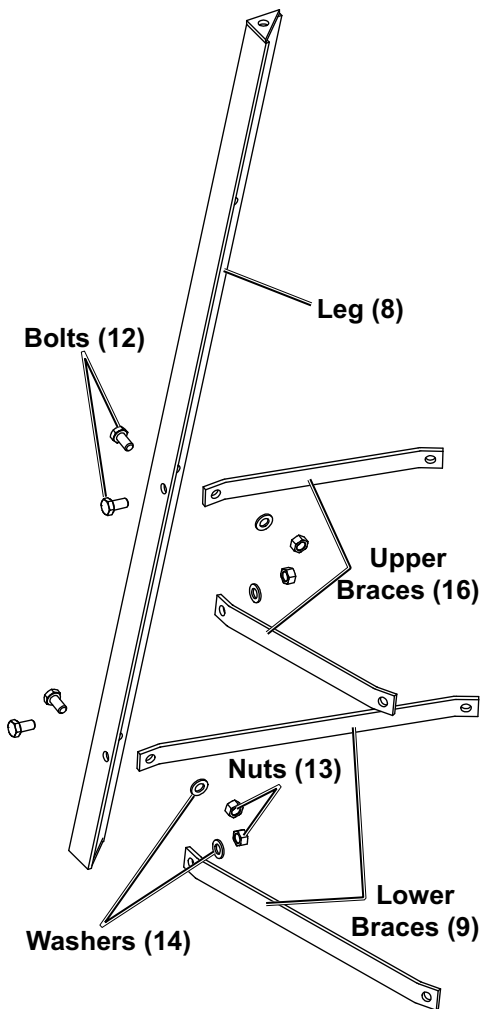

Figure A:

4. Turn the other two Legs (8) so that their closed ends with holes also face up.
5. Connect the Lower Braces (9) to the other two Legs' (8) lower holes.**
6. Use the other Lower Brace (9) to connect those two Legs' (8) other lower holes.**
7. Connect the Upper Braces (16) to the other two Legs' (8) middle holes.**
8. Use the other Upper Brace (16) to connect those two Legs' (8) other middle holes.**
9. Attach a Connector (15) to the upper hole on the side of each Leg (8), as shown. Install the Connectors with their long ends horizontal.**

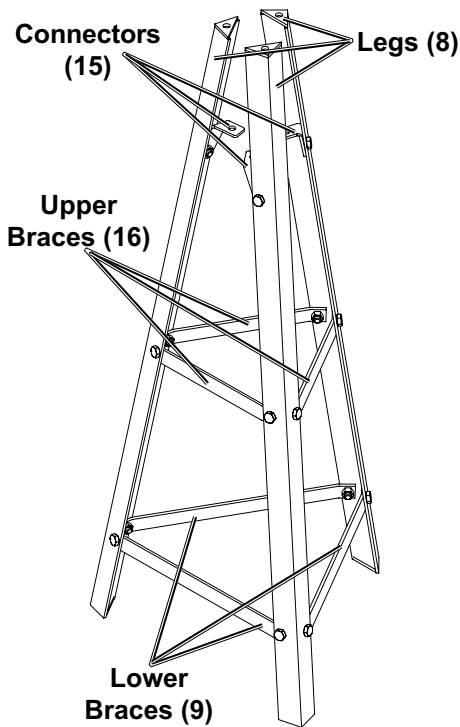

Figure B:

10. Set the Column (7) with its Upper and Lower Flange in place on the assembled base as shown. Make sure it is aligned properly.
11. Secure the Lower Flange of the Column (7) to the tops of the Connectors (15) using three Bolts (12), Washers, and Nuts.**
12. Secure the Upper Flange of the Column (7) to the tops of the Legs (8) using three Bolts (6), Washers, and Nuts. Fully tighten this hardware while holding the Legs (8) or clocking them in position so that they are not twisted relative to the Column (7) Upper Flange when the hardware is tight.

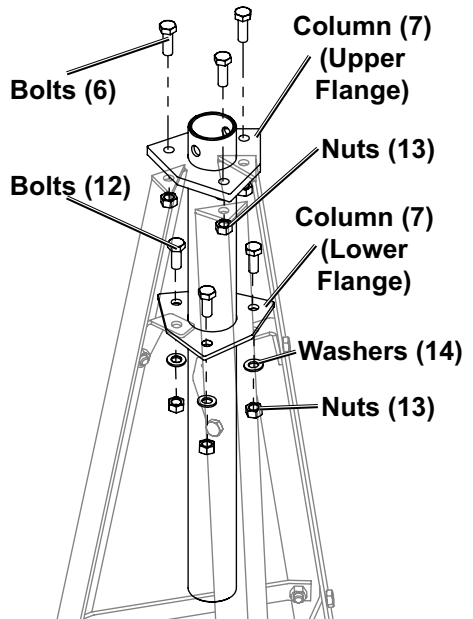

Figure C:

13. Fully tighten Bolts (12) and Nuts (13) securing the Legs (8), Braces (9,16), Connectors (15), and Lower Flange of the Column (7), left slightly loose for assembly purposes in Steps 1-11.
14. Set the Saddle (1) on top of the Screw Rod (2) and attach it securely with a Bolt (12).
15. Screw each Handle (10) securely into the threaded holes on the Handle Bracket (3).
16. Insert the Shaft (5) into the Column (7).
17. Line up one of the holes in the Shaft (5) with the holes in the Column (7) and insert the Lock Pin (11) to set the Shaft's height.

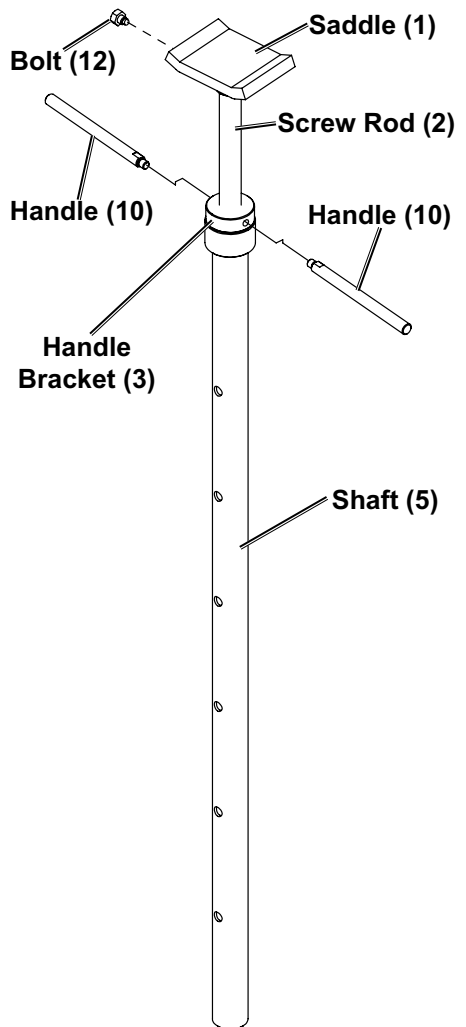

Figure D:

Operation Instructions



Read the **ENTIRE IMPORTANT SAFETY INFORMATION** section at the beginning of this document including all text under subheadings therein before set up or use of this product.

1. Remove the Lock Pin and lower the Shaft completely.
2. Turn the Handles so that the Saddle retracts as far as it will go.
3. Position the Saddle directly underneath the part to be supported.
4. Raise the Shaft so that the Saddle rests under the part needing support.
5. Reinsert the Lock Pin.
6. Turn the Handles to raise the Saddle until it securely supports the part. Make sure there is no wobble. If necessary, tighten Handles.



PLEASE READ THE FOLLOWING CAREFULLY

THE MANUFACTURER AND/OR DISTRIBUTOR HAS PROVIDED THE PARTS LIST AND ASSEMBLY DIAGRAM IN THIS DOCUMENT AS A REFERENCE TOOL ONLY. NEITHER THE MANUFACTURER OR DISTRIBUTOR MAKES ANY REPRESENTATION OR WARRANTY OF ANY KIND TO THE BUYER THAT HE OR SHE IS QUALIFIED TO MAKE ANY REPAIRS TO THE PRODUCT, OR THAT HE OR SHE IS QUALIFIED TO REPLACE ANY PARTS OF THE PRODUCT. IN FACT, THE MANUFACTURER AND/OR DISTRIBUTOR EXPRESSLY STATES THAT ALL REPAIRS AND PARTS REPLACEMENTS SHOULD BE UNDERTAKEN BY CERTIFIED AND LICENSED TECHNICIANS, AND NOT BY THE BUYER. THE BUYER ASSUMES ALL RISK AND LIABILITY ARISING OUT OF HIS OR HER REPAIRS TO THE ORIGINAL PRODUCT OR REPLACEMENT PARTS THERETO, OR ARISING OUT OF HIS OR HER INSTALLATION OF REPLACEMENT PARTS THERETO.

Parts List and Diagram

Part	Description	Qty
1	Saddle	1
2	Screw Rod	1
3	Handle Bracket	1
4	Bearing	1
5	Shaft	1
6	Bolt M10x25	3

Part	Description	Qty
7	Column	1
8	Leg	3
9	Lower Brace	3
10	Handle	2
11	Lock Pin	1
12	Bolt M10X20	19

Part	Description	Qty
13	Nut M10	21
14	Flat Washer	21
15	Connector	3
16	Upper Brace	3
17	Bearing	1

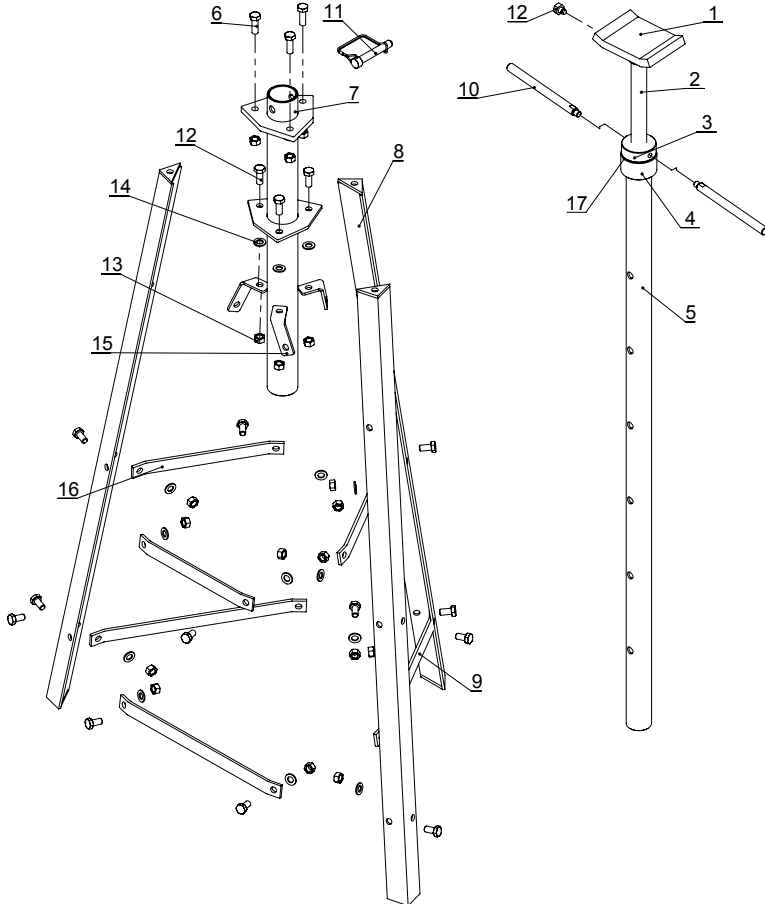

Record Product's Serial Number Here: _____

Note: If product has no serial number, record month and year of purchase instead.

Note: Some parts are listed and shown for illustration purposes only, and are not available individually as replacement parts. Specify UPC 792363616003 when ordering parts.

Limited 90 Day Warranty

Harbor Freight Tools Co. makes every effort to assure that its products meet high quality and durability standards, and warrants to the original purchaser that this product is free from defects in materials and workmanship for the period of 90 days from the date of purchase. This warranty does not apply to damage due directly or indirectly, to misuse, abuse, negligence or accidents, repairs or alterations outside our facilities, criminal activity, improper installation, normal wear and tear, or to lack of maintenance. We shall in no event be liable for death, injuries to persons or property, or for incidental, contingent, special or consequential damages arising from the use of our product. Some states do not allow the exclusion or limitation of incidental or consequential damages, so the above limitation of exclusion may not apply to you. THIS WARRANTY IS EXPRESSLY IN LIEU OF ALL OTHER WARRANTIES, EXPRESS OR IMPLIED, INCLUDING THE WARRANTIES OF MERCHANTABILITY AND FITNESS.

To take advantage of this warranty, the product or part must be returned to us with transportation charges prepaid. Proof of purchase date and an explanation of the complaint must accompany the merchandise. If our inspection verifies the defect, we will either repair or replace the product at our election or we may elect to refund the purchase price if we cannot readily and quickly provide you with a replacement. We will return repaired products at our expense, but if we determine there is no defect, or that the defect resulted from causes not within the scope of our warranty, then you must bear the cost of returning the product.

This warranty gives you specific legal rights and you may also have other rights which vary from state to state.

PITTSBURGH AUTOMOTIVE