

# Owner's Manual & Safety Instructions

**Save This Manual** Keep this manual for the safety warnings and precautions, assembly, operating, inspection, maintenance and cleaning procedures. Write the product's date code in the back of the manual near the assembly diagram (or month and year of purchase if product has no number). Keep this manual and the receipt in a safe and dry place for future reference.

25d

**HOLT**  
INDUSTRIES

## 2.3 GALLON MANUAL FLUID EXTRACTOR



**62643**

Visit our website at: <https://www.harborfreight.com>  
Email our technical support at: [productsupport@harborfreight.com](mailto:productsupport@harborfreight.com)





When unpacking, make sure that the product is intact and undamaged. If any parts are missing or broken, please call 1-800-444-3353 as soon as possible.

Copyright© 2025 by Harbor Freight Tools®. All rights reserved.  
No portion of this manual or any artwork contained herein may be reproduced in any shape or form without the express written consent of Harbor Freight Tools. Diagrams within this manual may not be drawn proportionally. Due to continuing improvements, actual product may differ slightly from the product described herein.  
Tools required for assembly and service may not be included.

### **⚠ WARNING**

**Read this material before using this product.  
Failure to do so can result in serious injury.  
SAVE THIS MANUAL.**

## WARNING SYMBOLS AND DEFINITIONS

	This is the safety alert symbol. It is used to alert you to potential personal injury hazards. Obey all safety messages that follow this symbol to avoid possible injury or death.
	Indicates a hazardous situation which, if not avoided, will result in death or serious injury.
	Indicates a hazardous situation which, if not avoided, could result in death or serious injury.
	Indicates a hazardous situation which, if not avoided, could result in minor or moderate injury.
	Addresses practices not related to personal injury.

## IMPORTANT SAFETY INFORMATION

### **WARNING**



Read all safety warnings and instructions.

*Failure to follow the warnings and instructions may result in serious injury.*

### Work Area

- Keep the work area clean and well lit.**  
Cluttered dark areas invite accidents.
- The work area should have adequate drainage to reduce the possibility of a fall due to slippery surfaces.
- Keep bystanders, children, and visitors away while operating.** Distractions can cause loss of control.

### Personal Safety

-  **Always wear eye protection.**  
Wear ANSI-approved safety goggles.
-  **Use safety equipment.**  
Wear ANSI-approved, heavy-duty, chemical resistant work gloves during set up or use.
- Follow all guidelines regarding materials being extracted, including MSDS instructions and EPA regulations.**
- Stay alert. Watch what you are doing and use common sense when operating. Do not use while tired or under the influence of drugs, alcohol, or medication.** A moment of inattention while operating may result in serious personal injury.
- Dress properly.** Do not wear loose clothing or jewelry. Contain long hair. Keep hair and clothing away from moving parts. Loose clothes, jewelry, or long hair can be caught in moving parts.
- Do not overreach. Keep proper footing and balance at all times.**  
Proper footing and balance enable better control of the tool in unexpected situations.

## Use

---

1. **DO NOT use to extract, siphon, or store dangerous chemicals: including gasoline, poisons, corrosives, solvents, or highly flammable liquids.**
2. **Use only with non-explosive lubricating fluids such as transmission fluid, brake fluid, power steering fluid, coolant, engine oil and gear oil or with water and water-based liquids.**
3. Do not use for more than one application. To prevent cross contamination, use a different Manual Fluid Extractor for each purpose.
4. Do not throw, drop, or mishandle this product.
5. Do not store the Manual Fluid Extractor, Suction Tube, or Extraction Tubes near or in areas of high temperatures, direct sunlight, rain, or snow.
6. Industrial applications must follow OSHA requirements.
7. This product is not a toy. Do not allow children to play with or near this item.
8. Use as intended only.
9. Inspect before every use; do not use if parts are loose or damaged.
10. Maintain product labels and nameplates. These carry important safety information. If unreadable or missing, contact Harbor Freight Tools for a replacement.
11. The warnings and cautions discussed in this manual cannot cover all possible conditions and situations that may occur. The operator must understand that common sense and caution are factors that cannot be built into this product, but must be supplied by the operator.

## Service

---

1. **Have the Manual Fluid Extractor serviced by a qualified repair person using only identical replacement parts.**  
This will ensure that the safety of the tool is maintained.
2. **Check for any condition that affects operation.**  
If damaged, have the Manual Fluid Extractor serviced before using. Many accidents are caused by poorly maintained tools.
3. **Store idle tools and equipment out of reach of children and other untrained people.**  
Tools and equipment are dangerous in the hands of untrained users.
4. **Maintain the tool with care.** Keep this product clean. A properly maintained tool is easier to control.



**SAVE THESE INSTRUCTIONS.**

## Specifications

Reservoir Tank Capacity	2.3 gallons (9.0 Liters)
Reservoir Tank Markings	2, 4, 6 and 8 Liters
Suction Tube Length	60"

**HOLT**  
INDUSTRIES

# Components and Controls



**HOLT**  
INDUSTRIES

## Operating Instructions



Read the **ENTIRE IMPORTANT SAFETY INFORMATION** section at the beginning of this document including all text under subheadings therein before set up or use of this product.

### **WARNING**

#### **TO PREVENT SERIOUS INJURY:**

Do not adjust or tamper with any control or component in a way not specifically explained within this manual. Improper adjustment can result in tool failure or other serious hazards.

Inspect Manual Fluid Extractor before use, looking for damaged, loose, and missing parts. If any problems are found, do not use Extractor until repaired.

Follow all guidelines regarding materials being extracted, including MSDS instructions and EPA regulations.

**Note:** For additional information regarding the parts listed in the following pages, refer to *Parts List and Diagram* on page 10.

## Tool Setup

---

Attach the Tube Holder (11) onto the two hooks located on side of Reservoir Tank (20). Refer to Figure A.

**Note:** The Tube Holder is used to retrieve fluid which drains from the ends of the extraction tubes upon their removal from the source.

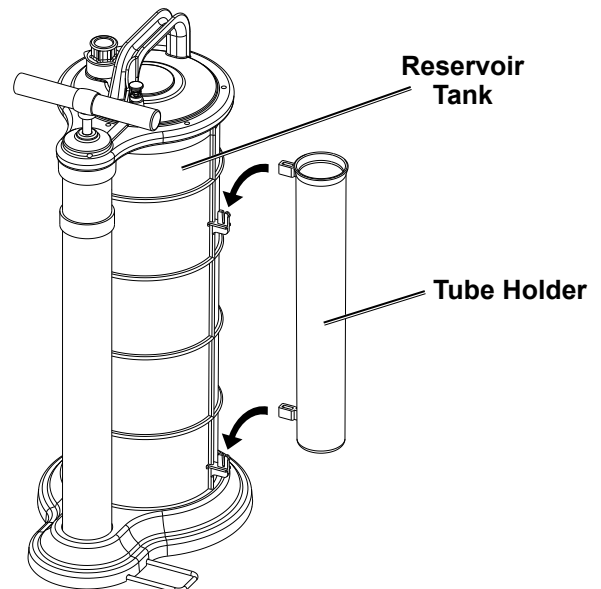

Figure A

**HOLT**  
INDUSTRIES

# General Operating Instructions

---

1. Before using the Manual Fluid Extractor on a vehicle, park the vehicle on a flat, level surface.
2. Shut down the vehicle and chock its tires.
3. Before beginning fluid extraction, disconnect the negative battery cable to prevent accidental starting of the vehicle's engine.

## Engine Oil or Transmission Fluid Extraction

---

1. When removing engine oil, run the engine for at least 5 minutes to warm the oil.
2. Remove the oil dipstick from the engine, or remove the transmission fluid dipstick or fill plug.
3. Insert the end of an Extracting Tube without the adapter into the dipstick opening of the engine until it reaches the bottom of the oil pan or into the dipstick fill hole of the transmission until it reaches the bottom of the transmission pan.
4. Connect the adapter end of the Main Suction Tube to the Fluid Inlet Coupler and insert the free end of the Main Suction Tube into the adapter on the end of the Extracting Tube.
5. Place one foot on the Foot Board. Lift the Pump Handle to the top position, and push it to the bottom position repeatedly to start the fluid extracting operation.
6. As the fluid starts to flow, continue pumping until all fluid has been extracted. When finished, disconnect the Main Suction Tube and remove the Extracting Tube from the dipstick opening.
7. Remove the Fluid Inlet Coupler from the Fluid Outlet Housing, pour the collected fluid into an appropriate container, and dispose of in accordance with all applicable local, state and federal laws.

**NOTE:** Narrower dipstick tubes may prevent insertion of the Extracting Tubes.



## Inspection, Maintenance, and Cleaning



Procedures not specifically explained in this manual must be performed only by a qualified technician.

### **⚠️ WARNING**

#### **TO PREVENT SERIOUS INJURY:**

Do not use damaged equipment. If abnormal noise, vibration, or leaking air occurs, have the problem corrected before further use.

Follow all guidelines regarding materials being extracted, including MSDS instructions and EPA regulations.

1. **BEFORE EACH USE**, inspect the general condition of the Fluid Extractor. Check for:
  - loose hardware
  - misalignment or binding of moving parts
  - cracked or broken parts
  - any other condition that may affect its safe operation.
2. **AFTER EVERY USE**, clean the Reservoir Tank to remove any accumulated debris.
3. **PERIODICALLY**, lubricate all moving parts of the pump assembly with petroleum jelly.
4. Store the Manual Fluid Extractor in a safe, dry, clean location out of reach of children and out of sunlight.

## Troubleshooting

<b>Problem</b>	<b>Possible Causes</b>	<b>Likely Solutions</b>
Unit does not extract fluid	<ol style="list-style-type: none"><li>1. Main Suction Tube detached.</li><li>2. Extracting Tube not positioned properly.</li><li>3. All fluid has been removed.</li></ol>	<ol style="list-style-type: none"><li>1. Reattach Main Suction Tube.</li><li>2. Firmly insert Extracting Tube into correct location.</li><li>3. Verify there is still fluid to be removed.</li></ol>
Decreased suction or tubes leaking fluid	Holes/cracks in tubes.	Check all suction/extraction tubes for cracks. Replace any defective tubes with new tubes. Do not repair old tubes.



Follow all safety precautions whenever diagnosing or servicing the Manual Fluid Extractor.

## **PLEASE READ THE FOLLOWING CAREFULLY**

---

THE MANUFACTURER AND/OR DISTRIBUTOR HAS PROVIDED THE PARTS LIST AND ASSEMBLY DIAGRAM IN THIS DOCUMENT AS A REFERENCE TOOL ONLY. NEITHER THE MANUFACTURER OR DISTRIBUTOR MAKES ANY REPRESENTATION OR WARRANTY OF ANY KIND TO THE BUYER THAT HE OR SHE IS QUALIFIED TO MAKE ANY REPAIRS TO THE PRODUCT, OR THAT HE OR SHE IS QUALIFIED TO REPLACE ANY PARTS OF THE PRODUCT. IN FACT, THE MANUFACTURER AND/OR DISTRIBUTOR EXPRESSLY STATES THAT ALL REPAIRS AND PARTS REPLACEMENTS SHOULD BE UNDERTAKEN BY CERTIFIED AND LICENSED TECHNICIANS, AND NOT BY THE BUYER. THE BUYER ASSUMES ALL RISK AND LIABILITY ARISING OUT OF HIS OR HER REPAIRS TO THE ORIGINAL PRODUCT OR REPLACEMENT PARTS THERETO, OR ARISING OUT OF HIS OR HER INSTALLATION OF REPLACEMENT PARTS THERETO.

## Parts List and Diagram

### Parts List

Part	Description	Qty
1	Release Button	1
2	Spring	1
3	Locking Bushing	1
4	O-Ring	1
5	Screw	1
6	Spring	1
7	Check Valve	1
8	Screw	6
9	Cover Housing	1
10	Bracket	2
11	Tube Holder	1
12	Fluid Inlet Coupler	1
13	O-Ring	1
14	O-Ring	1
15	Fluid Outlet Housing	1
16	O-Ring	1
17	Lock Nut	1
18	Relief Valve	1
19	O-Ring	1
20	Reservoir Tank	1
21	Nut	1
22	Base	1
23	Silencer	1
24	Screw	7
25	Foot Board	1

Part	Description	Qty
26	Bracket	1
27	Steel Ball	1
28	Rubber Washer	2
29	Clamp	1
30	Nut	1
31	Screw	1
32	Aluminum Tube	1
33	Handle Lid	1
34	Screw	1
35	Pump Handle	1
36	O-Ring	2
37	Screw	1
38	Shaft Set	1
38.1	Shaft	1
38.2	Spring	1
38.3	Flat Washer	1
38.4	Piston	1
38.5	Piston Spacer	1
38.6	O-Ring	1
38.7	Flat Washer	1
38.8	Nylon Nut	1
39	Extracting Tube (6mm) w/Adapter	1
40	Extracting Tube (7mm) w/Adapter	1
41	Main Suction Tube (10mm) w/Adapter	1

Record Product's Date Code Here: \_\_\_\_\_

**Note:** If product has no date code, record month and year of purchase instead.

**Note:** Some parts are listed and shown for illustration purposes only, and are not available individually as replacement parts. Specify UPC 193175569448 when ordering parts.

# Assembly Diagram

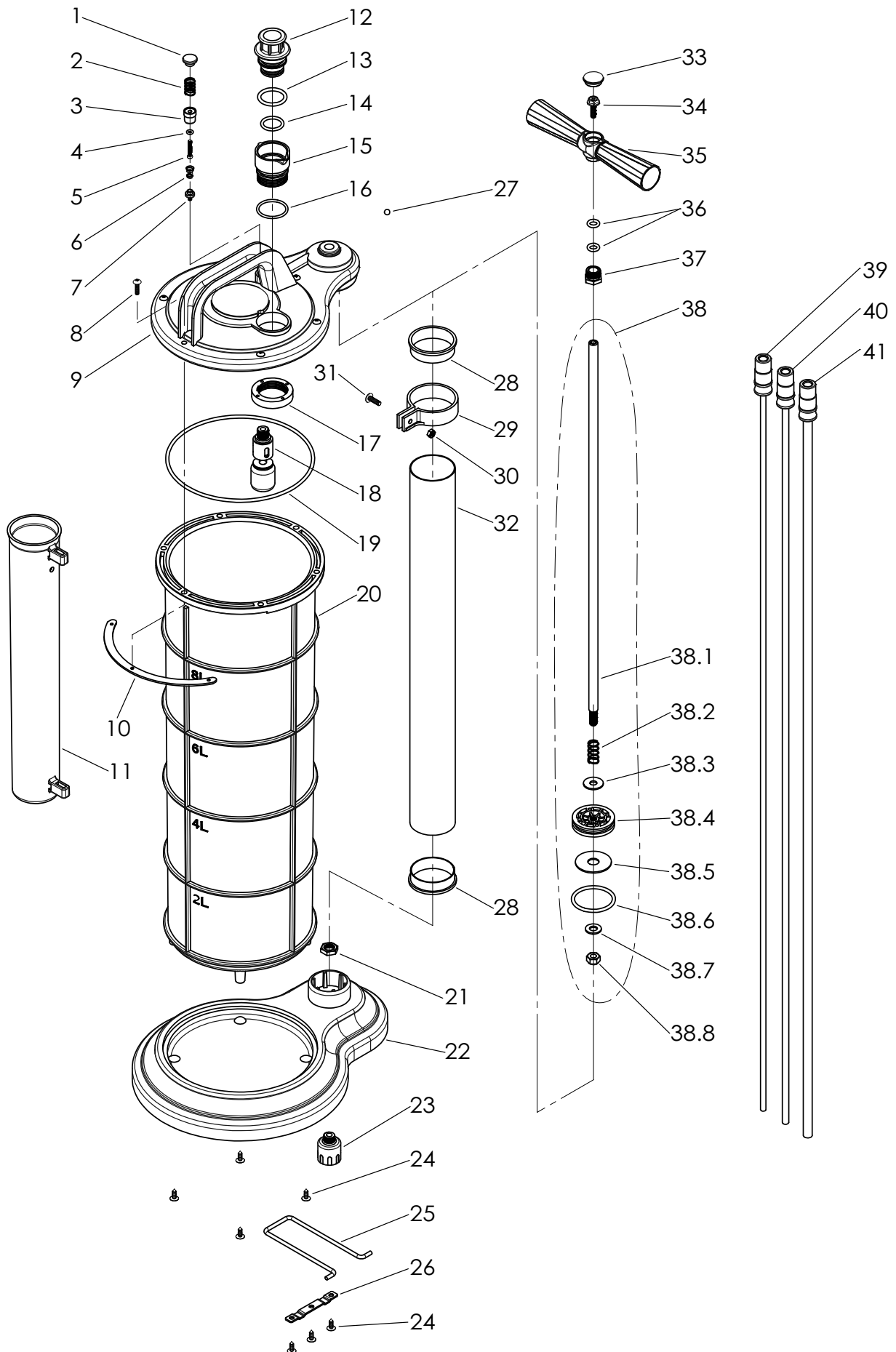

## Limited 90 Day Warranty

Harbor Freight Tools Co. makes every effort to assure that its products meet high quality and durability standards, and warrants to the original purchaser that this product is free from defects in materials and workmanship for the period of 90 days from the date of purchase. This warranty does not apply to damage due directly or indirectly, to misuse, abuse, negligence or accidents, repairs or alterations outside our facilities, criminal activity, improper installation, normal wear and tear, or to lack of maintenance. We shall in no event be liable for death, injuries to persons or property, or for incidental, contingent, special or consequential damages arising from the use of our product. Some states do not allow the exclusion or limitation of incidental or consequential damages, so the above limitation of exclusion may not apply to you. THIS WARRANTY IS EXPRESSLY IN LIEU OF ALL OTHER WARRANTIES, EXPRESS OR IMPLIED, INCLUDING THE WARRANTIES OF MERCHANTABILITY AND FITNESS.

To take advantage of this warranty, the product or part must be returned to us with transportation charges prepaid. Proof of purchase date and an explanation of the complaint must accompany the merchandise. If our inspection verifies the defect, we will either repair or replace the product at our election or we may elect to refund the purchase price if we cannot readily and quickly provide you with a replacement. We will return repaired products at our expense, but if we determine there is no defect, or that the defect resulted from causes not within the scope of our warranty, then you must bear the cost of returning the product.

This warranty gives you specific legal rights and you may also have other rights which vary from state to state.

**HOLT**  
**INDUSTRIES**