

Owner's Manual & Safety Instructions

Save This Manual Keep this manual for the safety warnings and precautions, assembly, operating, inspection, maintenance and cleaning procedures. Write the product's serial number in the back of the manual near the assembly diagram (or month and year of purchase if product has no number). Keep this manual and the receipt in a safe and dry place for future reference.

REV 15d

ITEM 62665

1,090 LB. CAPACITY

HaulMaster®

12" WHEELS

UTILITY TRAILER

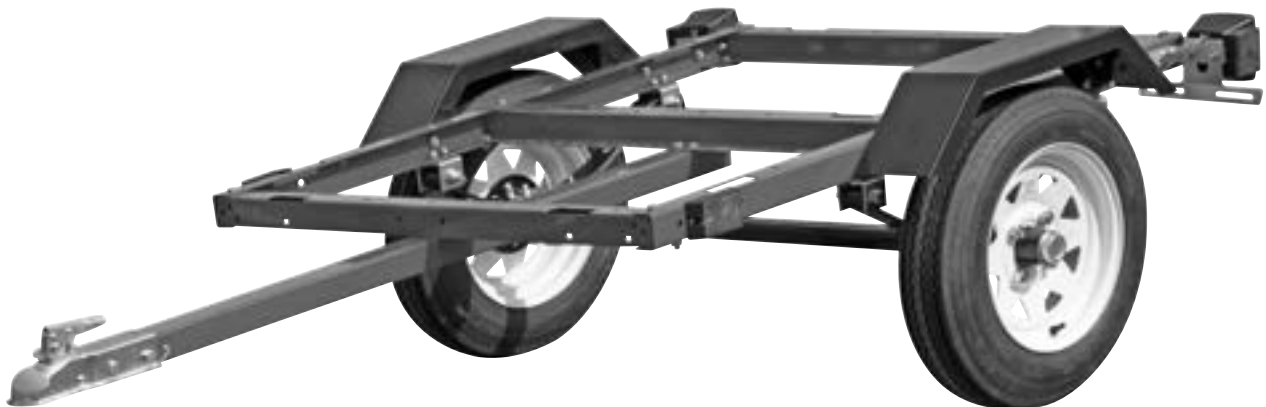

Visit our website at: <http://www.harborfreight.com>
Email our technical support at: productsupport@harborfreight.com

When unpacking, make sure that the product is intact and undamaged. If any parts are missing or broken, please call 1-888-866-5797 as soon as possible.

Copyright© 2015 by Harbor Freight Tools®. All rights reserved.
No portion of this manual or any artwork contained herein may be reproduced in any shape or form without the express written consent of Harbor Freight Tools. Diagrams within this manual may not be drawn proportionally. Due to continuing improvements, actual product may differ slightly from the product described herein.
Tools required for assembly and service may not be included.

⚠ WARNING

**Read this material before using this product.
Failure to do so can result in serious injury.
SAVE THIS MANUAL.**

Table of Contents

Safety	3	Maintenance	24
Assembly	6	Parts List and Diagram	26
Specifications	15	Reporting Safety Defects	28
Operation	16	Warranty	28



WARNING SYMBOLS AND DEFINITIONS

	This is the safety alert symbol. It is used to alert you to potential personal injury hazards. Obey all safety messages that follow this symbol to avoid possible injury or death.
	Indicates a hazardous situation which, if not avoided, will result in death or serious injury.
	Indicates a hazardous situation which, if not avoided, could result in death or serious injury.
	Indicates a hazardous situation which, if not avoided, could result in minor or moderate injury.
	Addresses practices not related to personal injury.

VDC	Volts Direct Current
A	Amperes
	WARNING marking concerning Risk of Eye Injury. Wear ANSI-approved safety goggles with side shields.

	Read the manual before set-up and/or use.
	WARNING marking concerning Risk of Fire. Connect trailer wiring to properly fused circuit only.

IMPORTANT SAFETY INFORMATION

⚠️ WARNING

Read all safety warnings and instructions.
Failure to follow the warnings and instructions may result in serious injury.
Save all warnings and instructions for future reference.

The warnings, precautions, and instructions discussed in this instruction manual cannot cover all possible conditions and situations that may occur. It must be understood by the operator that common sense and caution are factors which cannot be built into this product, but must be supplied by the operator.

Assembly Safety

1. Keep work area clean and dry. Cluttered, damp, or wet work areas invite injuries.
2. Keep children away from work area.
3. Use eye protection. Wear ANSI-approved safety impact eye goggles when assembling this Trailer.
4. Do not modify this Trailer, and do not use this Trailer for a purpose for which it was not intended.
5. **WARNING:** The cord/wiring of this product contains lead and/or di (2-ethylhexyl) phthalate (DEHP), chemicals known to the State of California to cause cancer, and birth defects or other reproductive harm. Wash hands after handling. (California Health & Safety Code § 25249.5, *et seq.*)

Connection Safety

1. Dress safely while connecting/disconnecting. Do not wear loose clothing or jewelry, as they can become caught in moving parts. Wear a protective hair covering to prevent long hair from becoming caught in moving parts. If wearing a long-sleeve shirt, roll sleeves up above elbows. Wearing safety work shoes is recommended.
2. Do not setup or use this Trailer if under the influence of alcohol or drugs. Read warning labels on prescriptions to determine if your judgement or reflexes are impaired while taking drugs. If there is any doubt, do not attempt to use this Trailer.
3. Stay alert. Watch what you are doing at all times. Use common sense. Do not setup or use this Trailer when you are tired or distracted from the job at hand.
4. The tail light bulbs supplied with this Trailer are for a 12 volt DC (negative ground) electrical system only. Do not attempt to power the Light Bulbs with any other type or voltage electrical current.
5. Make sure the Hitch Coupler and the vehicle's ball hitch (not included) are of equal mating size (1-7/8") and are rated equal to or greater than the weight of the Trailer and its payload.
6. Before each use, attach the Trailer's Safety Chain (1) to the towing vehicle. Attach the Safety Chain to the towing vehicle's rear bumper or frame with equal length on each side and chains crossed under the trailer tongue. Allow just enough chain length for unrestricted turning. Do not allow the Safety Chain to drag on the ground.

Loading Safety

1. Do not exceed the Trailer's maximum payload capacity of 1090 lb.
2. Properly and safely secure the payload in the Trailer. Load the Trailer evenly from side to side with 60% of the load forward of the Axle.
3. Make sure the towing vehicle and its hitch are both rated to safely tow the Trailer and its payload. The towing capacity of the hitch is typically stamped on the hitch drawbar.

Operation Safety

Note: Selected recommendations in this section are adapted from *TOWING A TRAILER - Being Equipped for Safety*, published by NHTSA. For full details, see that document.

1. This Trailer is not a toy. Do not allow children to play on or near this item.
2. Take time to practice before driving on main roads.
3. Never allow anyone to ride in or on the trailer.
4. Do not transport animals in this trailer.

Before Each Use

1. Check Tire (13) condition and air pressure.
2. Make sure wheel lug nuts/bolts are properly tightened.
3. Make sure hitch, coupler, draw bar, and other equipment that connect the trailer and the tow vehicle are properly secured and adjusted.
4. Make sure wiring is properly connected — not touching the road, but loose enough to make turns without disconnecting or damaging the wires.
5. Make sure all running lights, brake lights, turn signals, and hazard lights are working.
6. Check that all items are securely fastened on and in the trailer.
7. Be sure the trailer jack, tongue support, and any attached stabilizers are raised and locked in place.
8. Check load distribution to make sure the tow vehicle and trailer are properly balanced front to back and side to side.
9. Check side- and rear-view mirrors to make sure you have good visibility.
10. Check routes and restrictions on bridges and tunnels.
11. Make sure you have wheel chocks and jack stands.
12. Check trailer for loose bolts and nuts, structural cracks and bends, and any other condition that may affect its safe operation. Do not use the Trailer even if minor damage appears.

General Handling

1. Use the driving gear that the towing vehicle manufacturer recommends for towing.
2. Drive at moderate speeds. This will place less strain on your tow vehicle and trailer. Trailer instability (sway) is more likely to occur as speed increases. **Do not exceed 45 miles per hour when towing the Trailer.**
3. Avoid sudden stops and starts that can cause skidding, sliding, or jackknifing.
4. Avoid sudden steering maneuvers that might create sway or undue side force on the trailer.
5. Slow down when traveling over bumpy roads, railroad crossings, and ditches.
6. Make wider turns at curves and corners. Because your trailer's wheels are closer to the inside of a turn than the wheels of your tow vehicle, they are more likely to hit or ride up over curbs.
7. To control swaying caused by air pressure changes and wind buffeting when larger vehicles pass from either direction, release the accelerator pedal to slow down and keep a firm grip on the steering wheel.

Braking

1. Allow considerably more distance for stopping.
2. If you have an electric trailer brake controller and excessive sway occurs, activate the trailer brake controller by hand. Do not attempt to control trailer sway by applying the tow vehicle brakes; this will generally make the sway worse.
3. Always anticipate the need to slow down. To reduce speed, shift to a lower gear and press the brakes lightly.

Acceleration and Passing

1. When passing a slower vehicle or changing lanes, signal well in advance and make sure you allow extra distance to clear the vehicle before you pull back into the lane.
2. Pass on level terrain with plenty of clearance. Avoid passing on steep upgrades or downgrades.
3. If necessary, downshift for improved acceleration or speed maintenance.
4. When passing on narrow roads, be careful not to go onto a soft shoulder. This could cause your trailer to jackknife or go out of control.

Downgrades and Upgrades

1. Downshift to assist with braking on downgrades and to add power for climbing hills.
2. On long downgrades, apply brakes at intervals to keep speed in check. Never leave brakes on for extended periods of time or they may overheat.
3. Some tow vehicles have specifically calibrated transmission tow-modes. Be sure to use the tow-mode recommended by the manufacturer.

Backing Up

1. Put your hand at the bottom of the steering wheel. To turn left, move your hand left. To turn right, move your hand right.
2. Back up slowly.
3. Because mirrors cannot provide all of the visibility you may need when backing up, have someone outside at the rear of the trailer to guide you whenever possible.
4. Use slight movements of the steering wheel to adjust direction. Exaggerated movements will cause greater movement of the trailer.
5. If you have difficulty, pull forward and realign the tow vehicle and trailer and start again.

Parking

1. Try to avoid parking on grades.
 2. If possible, have someone outside to guide you as you park.
 3. **Once stopped, but before shifting into Park:**
 - a. Have someone place blocks on the downhill side of the trailer wheels.
 - b. Apply the parking brake.
 - c. Shift into Park. (first or reverse gear for manual transmissions)
 - d. Then remove your foot from the brake pedal.
 4. **Before uncoupling a trailer:**
 - a. Place blocks at the front and rear of the trailer tires to ensure that the trailer does not roll away when the coupling is released.
 - b. An unbalanced load may cause the tongue to suddenly rotate upward; therefore, before uncoupling, place jack stands under the rear of the trailer to prevent injury.
- Following this parking sequence is important to make sure your vehicle does not become locked in Park because of extra load on the transmission.

TRAILER LICENSING NOTICE

Some states may consider this Trailer a vehicle requiring registration, licensing, and titling. Check with your State Department of Motor Vehicles for information and guidance on registering, licensing, and titling the Trailer.

Maintenance Safety

1. Maintain labels and nameplates on the trailer. These carry important information. If unreadable or missing, contact Harbor Freight Tools for a replacement.
2. Replacement parts and accessories: when servicing, use only identical replacement parts. Only use accessories intended for use with this Trailer. Approved accessories are available from Harbor Freight Tools.
3. Maintain this Trailer with care. Keep this Trailer clean and dry for better and safer performance.
4. For your safety, service and maintenance should be performed regularly by a qualified technician.
5. When not in use, store Trailer in a dry location to inhibit rust. Lock up Trailer, and keep out of reach of children.



SAVE THESE INSTRUCTIONS.

Assembly Instructions



Read the **ENTIRE IMPORTANT SAFETY INFORMATION** section at the beginning of this manual including all text under subheadings therein before set up or use of this Trailer.

Note: For additional information regarding the parts listed in the following pages, refer to *Parts List and Diagram* on page .

1. On a flat, level surface, lay out the Left Side Rail (21), Right Side Rail (23), and three Cross Members (22) upside down. Lay out the four Spring Hangers (20). Assemble the parts, using 20 sets of M10x20 Bolts and M10 Nuts (27). Refer to Figure A.

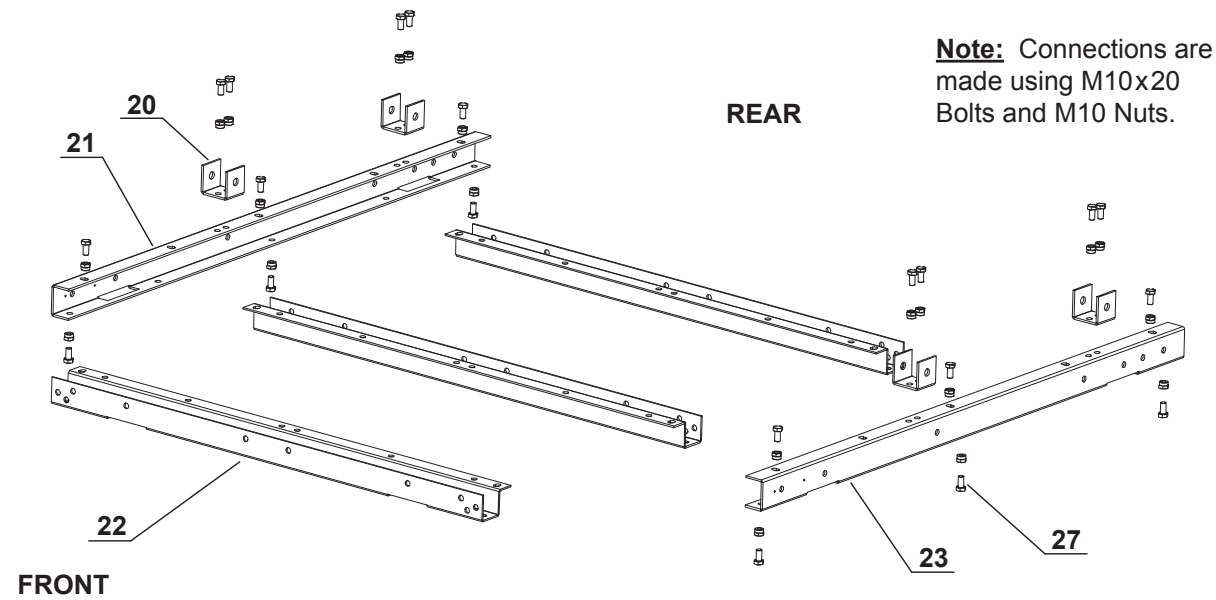

Note: Connections are made using M10x20 Bolts and M10 Nuts.

Figure A: Bed Rail Assembly

2. Attach the Tow Bar (3) to the bed rail assembly at the front and middle Cross Members, using four sets of M10x20 Bolts and M10 Nuts (27). Refer to Figure B.

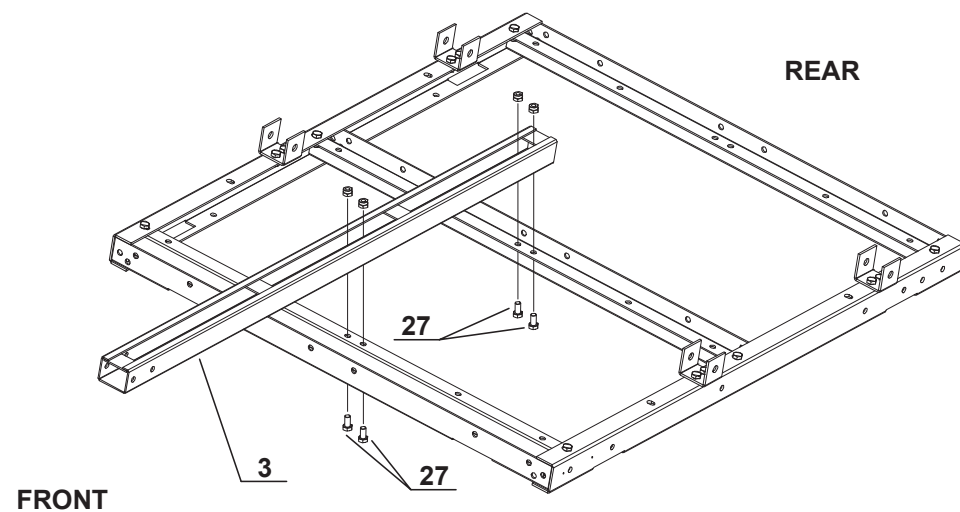

Figure B: Tow Bar Assembly

3. Attach one Fender (18) to the Right Side Rail (23) using two sets of M10x20 Bolts and M10 Nuts (27). Refer to Figure C.

4. Attach remaining Fender (18) to the Left Side Rail (21) using two sets of M10x20 Bolts and M10 Nuts (27).

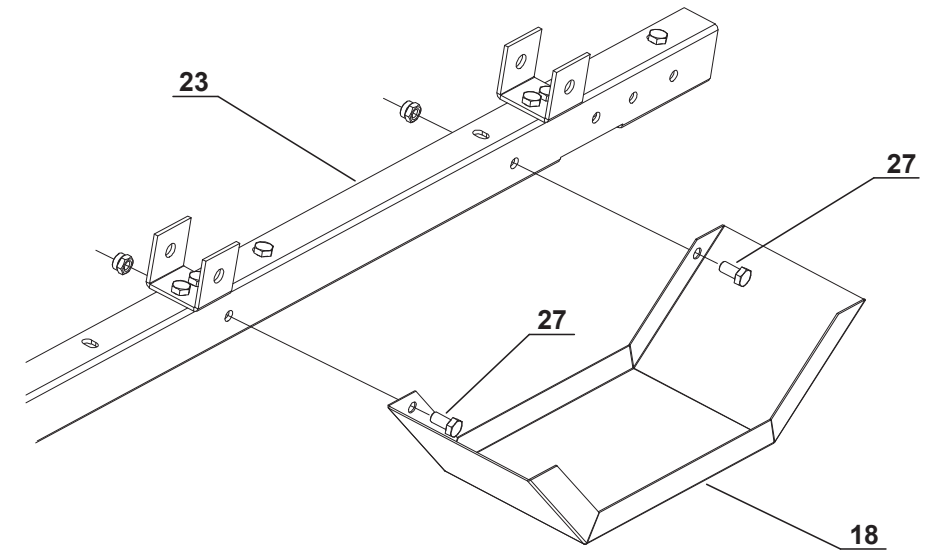

Figure C: Fender Assembly (Right Side View)

5. Attach the two Springs (5) to the Spring Hangers (20) on the Left and Right Side Rails (21, 23) with the spring eyes facing forward, using two sets of M12x80 Bolts and M12 Nuts (6) per Spring. Leave these Bolts loose temporarily to allow proper assembly in the next steps.
6. Place the Axle (4) on top of the Springs. Align depressions on Axle with protrusions on Springs.
7. On each end of the Axle, place Spring Plates (7) under Springs and insert U-Bolts (8) downward over the Axle and through the mounting holes in the Spring Plates. Adjust the Spring Plates slightly to allow the holes to line up.
8. Secure the Axle with M10 Nuts screwed onto the U-Bolts, then tighten the M12x80 Bolts and M12 Nuts left loose in step 5 to secure Spring assemblies.

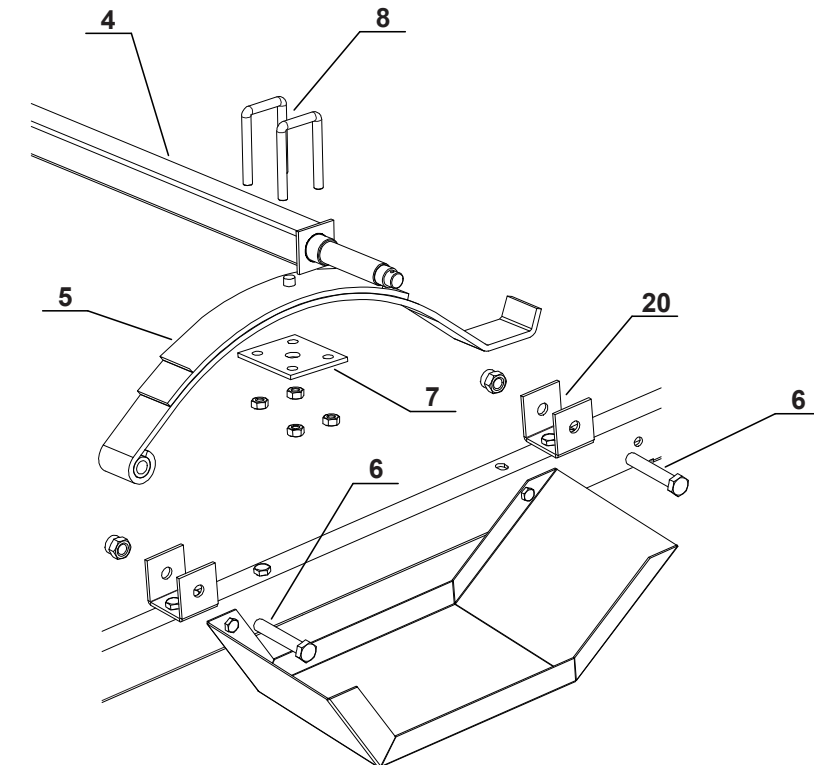

Figure D: Spring/Axle Assembly

Bearing Packing Instructions

WARNING! Whenever a hub is disassembled (if a hub on a new unit requires assembly or a hub is disassembled for maintenance), the following procedure **MUST** be obeyed. Failure to read and obey all of the following instructions completely will void the warranty and can result in damage to the Trailer, property damage, or serious injury.

- Using a suitable solvent, thoroughly clean the bearings and the rest of the parts in the Hub Assembly of all grease, dirt, metal shavings, or any other foreign object. **The parts must be cleaned even if they are new or appear clean.**
- Allow all pieces to dry completely.
- Make sure that your hands are thoroughly clean and the bearing packer (not included) is also thoroughly clean.
- Place fresh, clean bearing grease in the packer.
- With the grease-filled bearing packer in one hand and the bearing in the other, press the bearing into the grease, forcing the grease inside the slots in the bearing. Continue doing this until every slot in the bearing is completely full of grease.
- Continue assembling the hub/wheel assembly beginning with step 9 on page 8, being careful not to get any dirt or debris on any part of the assembly.

- Carefully slide the Hub Assemblies (9) over the spindles at each end of the Axle (4).
- Insert the Bearings (10) and Flat Washers (11) on the spindles. Screw a Castle Nut (12) tightly onto each spindle. Then back the Castle Nut off slightly so that the Hubs can just move freely.
- Insert a Cotter Pin (14) through the Castle Nut and hole at the end of each spindle. Bend the Cotter Pin back, locking it and the Nut in place.
- Fill the Dust Caps (13) with bearing grease. Press a Dust Cap onto each Hub Assembly.
- Grease each grease fitting located on the backside of each Hub Assembly.
- Install a Tire/Wheel Assembly (15) on each Hub Assembly. Secure each Tire/Wheel Assembly using the Lug Nuts (17). **Torque the Lug Nuts to 85–90 ft. lb.**

NOTE: PERIODICALLY, GREASE SEAL (16) ON BACKSIDE OF HUB ASSEMBLY (9).

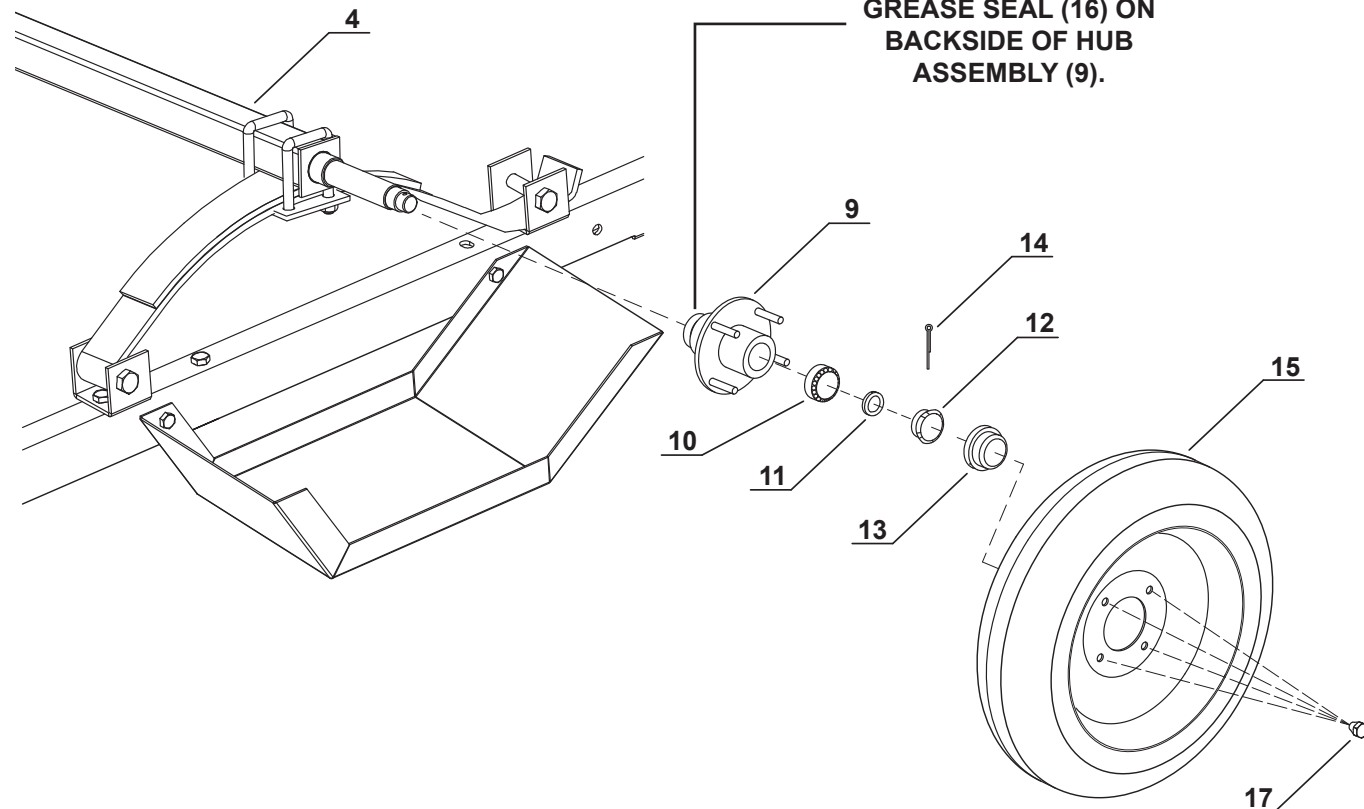

Figure E: Hub/Wheel Assembly

- With assistance, turn the Trailer assembly right side up.
- Attach the Coupler (2) to the Tow Bar (3), using two sets of M10x85 Bolts and M10 Nuts (29). When installing the front Bolt, thread it through the center link of the Safety Chain (1) to secure the Chain to the Coupler.
- Lock the Coupler Trigger, using its Locking Pin and R-Clip (30).
- Attach the Light Brackets (26) to the Left and Right Side Rails using four sets of M10x20 Bolts and M10 Nuts (27).
- Attach the License Plate Bracket (25) with the Left Tail Light (19) to the Light Bracket on the Left Side Rail, using M10 Nuts.
- Attach the Right Tail Light (24) to the Light Bracket on the Right Side Rail, using M10 Nuts.
- Remove the lenses from the Side Running Lights (28). Run the wire lead of one Side Running Light through the center hole located at the front end of the Left Side Rail. Then attach the Side Running Light to the Left Side Rail, using 4mm Self-Tapping Screws from the light package.
- Run the wire lead of the remaining Side Running Light through the center hole located at the front end of the Right Side Rail. Then attach the Side Running Light to the Right Side Rail, using 4mm Self-Tapping Screws.
- Reinstall the lenses on the two Side Running Lights.

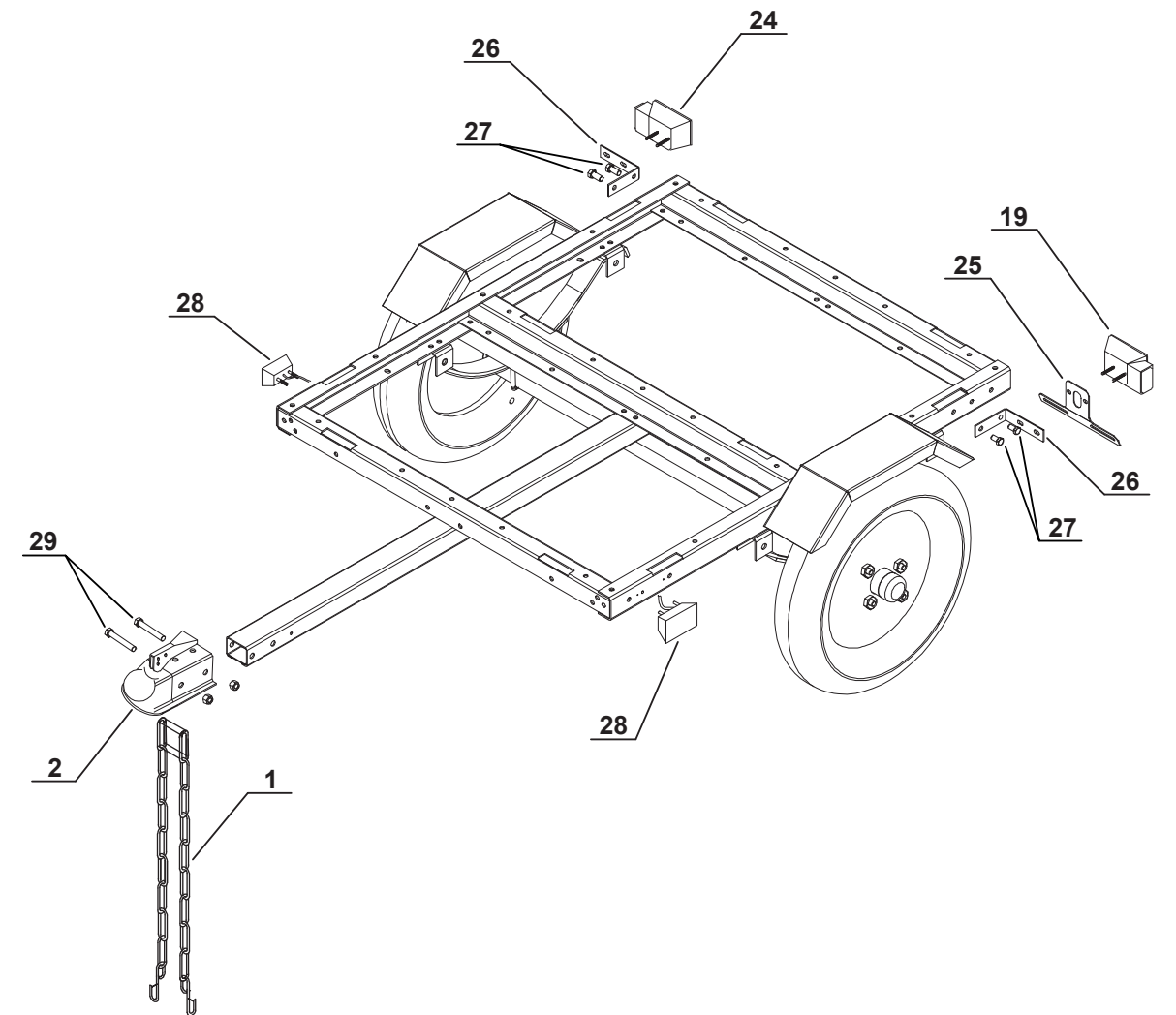

Figure F: Coupling Attachment/Light Installation

Note: Only a qualified technician should perform the electrical service that may be needed to enable your particular make/model vehicle to power the Trailer's 12 volt DC lighting system. This is beyond the scope of this manual.

24. Have a qualified service technician install a 4-wire, 12VDC connector in the trunk area of the towing vehicle.
25. Locate the vehicle's connector plug near the Trailer's Coupler (2) and lay out the Trailer's wiring harness wires.
26. Connect the brown wire to the vehicle's left tail light by stripping, wrapping, and taping the connector plug.
27. Connect the yellow wire to the vehicle's left signal and stop light wire.
28. Connect the green wire to the vehicle's right signal and stop light wire.

Note: Some foreign vehicles may require an adapter to convert their 5-wire system to a 4-wire vehicle connector plug.

29. Attach the white ground wire at the plug end of the wiring harness to the small mounting hole in the Tow Bar (3) with a 1/4" tapping screw (not included).

30. Leave about 18" of wire beyond the Coupler and run the wiring harness along the inside of the Tow Bar to the Right Side Rail (23). Then split the yellow/brown wires from the green/brown wires.
31. Run the yellow/brown wires along the inside of the front Cross Member (22) to the Side Running Light (28) on the Left Side Rail (21). Run the green/brown wires along the inside of the Right Side Rail to the other Side Running Light.
32. Connect the wire lead from the two Side Running Lights to the brown wire on each side of the trailer, using wire connectors. Then insert wire clips along the entire length of the side rails of the Trailer to hold down the wiring harness.
33. Run the yellow/brown wires to the Left Tail Light (19). Strip approximately 3/4" of insulation off the ends of the wires. Connect the yellow wire to the yellow wire of the Left Tail Light. Connect the brown wire to the brown wire of the Left Tail Light.
34. Run the green/brown wires to the Right Tail Light (24). Strip approximately 3/4" of insulation off the ends of the wires. Connect the green wire to the green wire of the Right Tail Light. Connect the brown wire to the brown wire of the Right Tail Light.

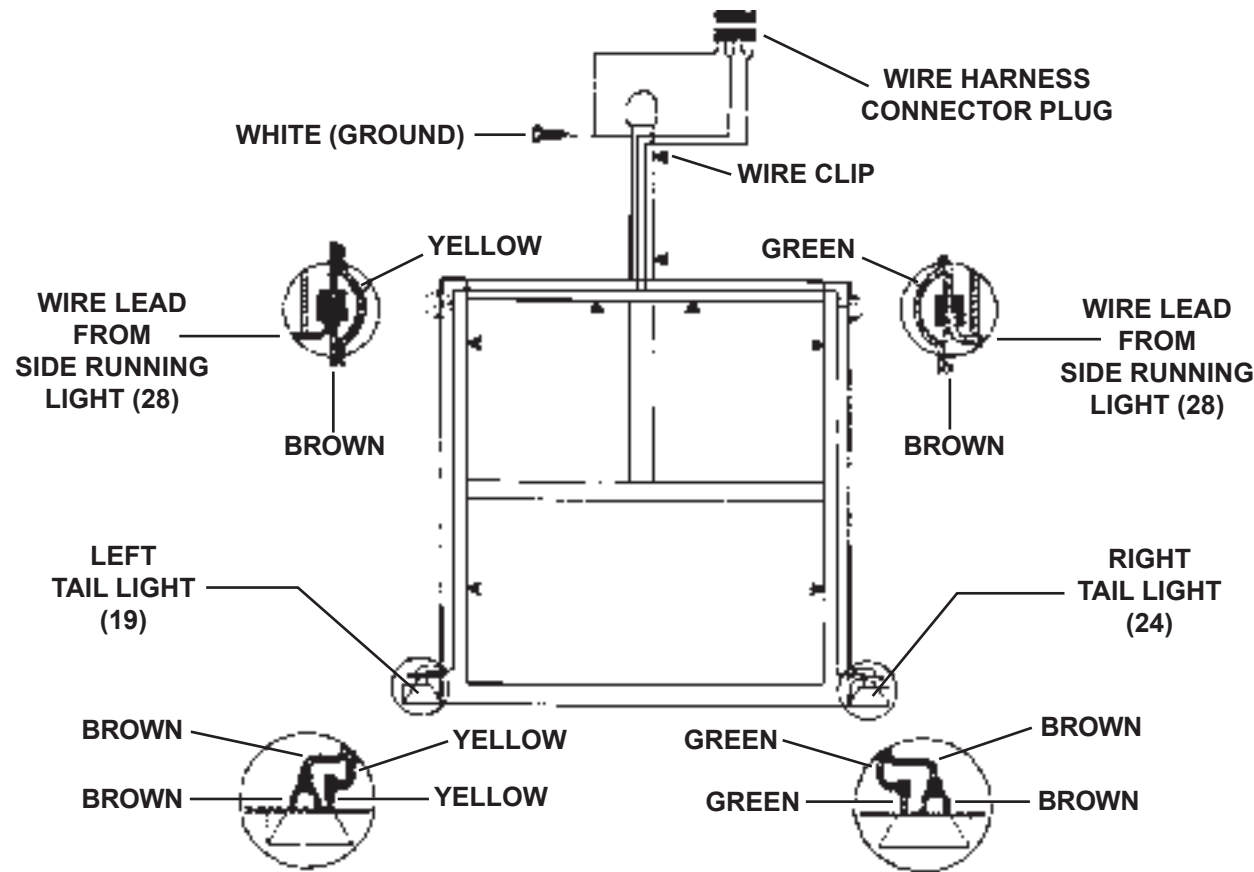

Figure G: Trailer Wiring

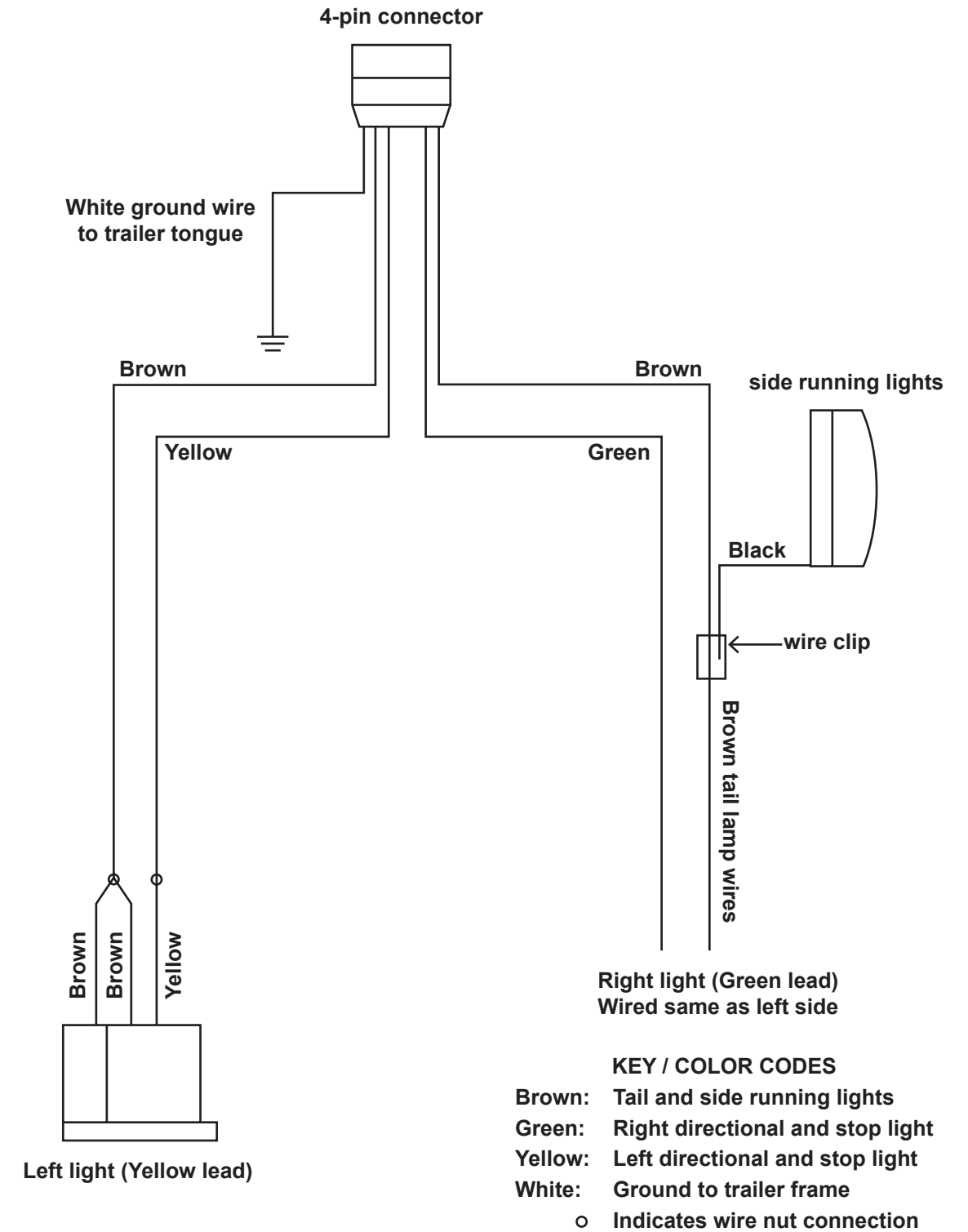

Figure H: Wiring Diagram

Note: Some trailer tail lights will have two leads instead of three. They connect to the harness leads the same way; brown to brown, color to color.

Optional Rail Installation (not included)

Minimum Required Parts:

- a. **Qty. 4:** 1"x4"x46" lumber (not included).
- b. **Qty. 4:** 1"x4"x37" lumber (not included).
- c. **Qty. 8:** 1"x4"x18" lumber (not included).
- d. **Qty. 8:** 2"x2"x3-1/2" Steel Angle (not included).
- e. **Qty. 32:** 3/8"x1-3/4" Cross Head Bolt (not included).
- f. **Qty. 32:** 3/8"x2-3/8" Cross Head Bolt (not included).
- g. **Qty. 64:** 3/8" Spring Washer (not included).
- h. **Qty. 64:** 3/8" Flat Washer (not included).
- i. **Qty. 64:** 3/8" Hex Nut (not included).

1. Cut the Stakes, Front End Rails, Back End Rails, and Side Rails to the sizes indicated in Figure I.
2. Drill 3/8" holes through the Stakes at the locations indicated in Figure I.

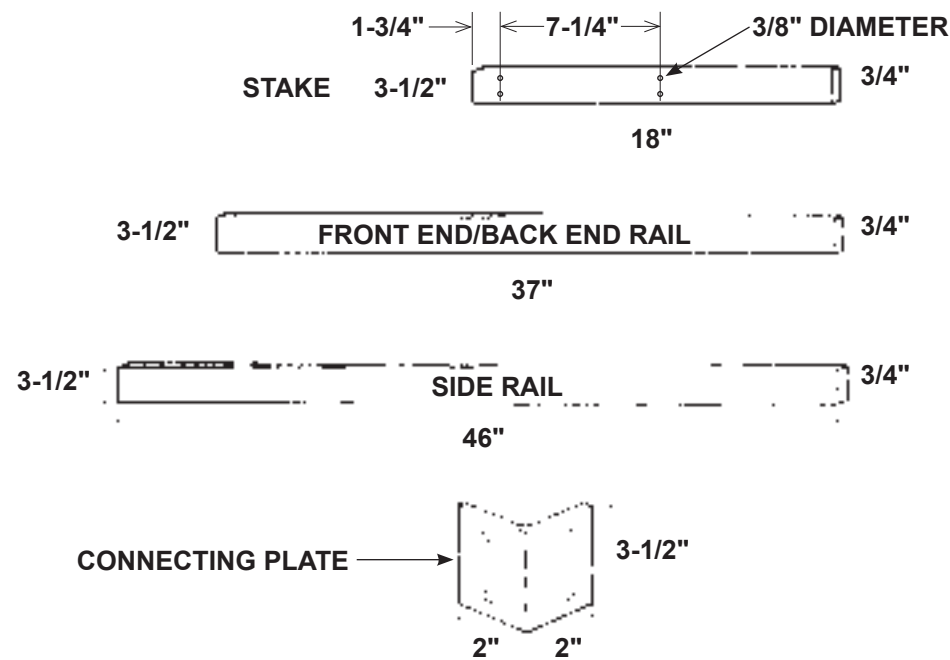

Figure I: Stake Dimensions and Hole Locations

3. To determine where to drill 3/8" mounting holes in the Front End Rails, Back End Rails, and Side Rails, first place the eight pre-drilled Stakes in the eight stake slots located on the Trailer frame. With assistance, hold the Side Rails and Front End/Back End Rails in position against the Stakes and mark mounting hole locations with a pencil. Refer to Figure J for approximate Rail positioning.
4. Drill 3/8" holes through the Side Rails and Front End/Back End Rails at the marked locations.
5. Attach the Side Rails and Front End/Back End Rails to the Stakes, using 3/8" x 2-3/8" Cross Head Bolts, 3/8" Flat Washers, 3/8" Spring Washers, and 3/8" Hex Nuts.
6. Place the Connecting Plates in position against the Side Rails and Front End/Back End Rails in the corners where they meet and use as a template to mark mounting hole locations with a pencil.
7. Drill 3/8" holes through the Side Rails and Front End/Back End Rails at the marked locations.
8. Attach the Connecting Plates to the Side Rails and Front End/Back End Rails, using 3/8" x 1-3/4" Cross Head Bolts, 3/8" Flat Washers, 3/8" Spring Washers, and 3/8" Hex Nuts.

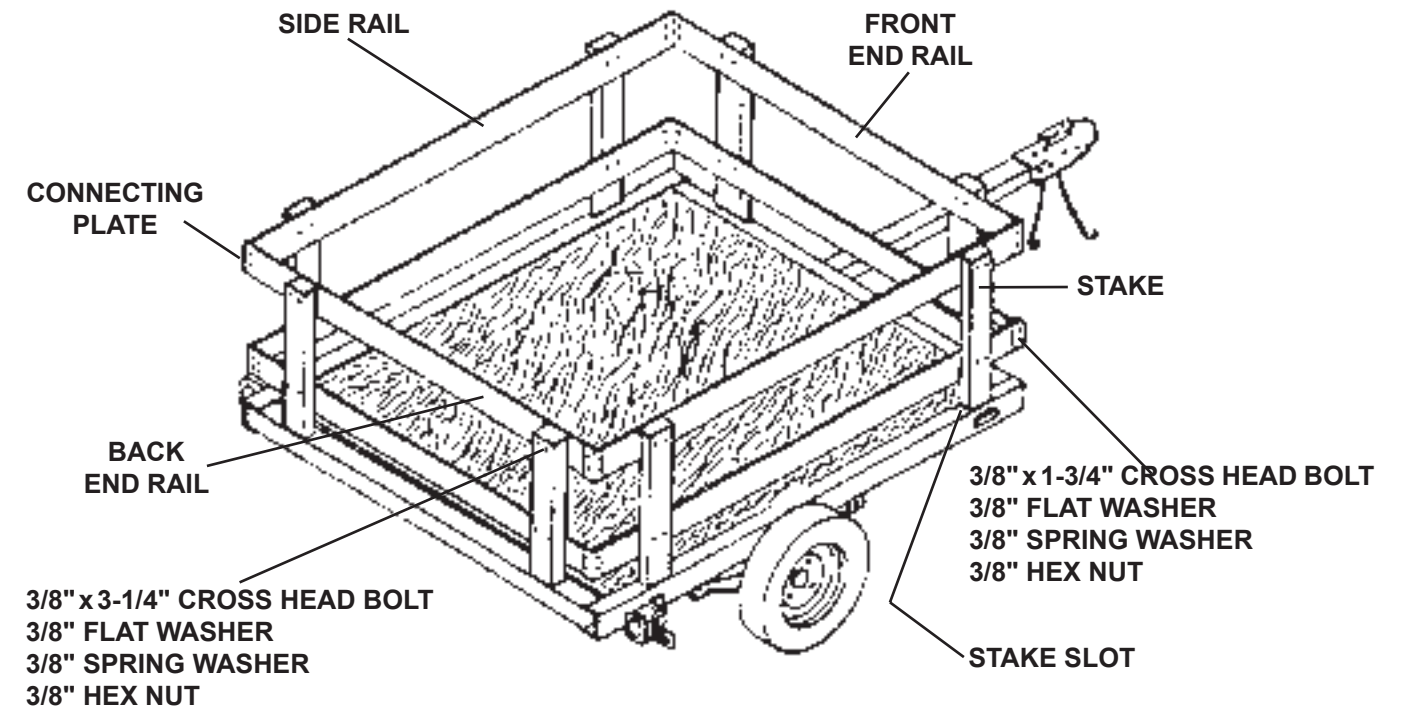

Figure J: Stake Assembly



Optional Bed Installation (not included)

Minimum Required Parts:

- a. **Qty. 1:** 3/4" thick Plywood (not included).
 - b. **Qty. 12:** 3/8" x 1-1/2" Cross Head Bolts (not included).
 - c. **Qty. 12:** 3/8" Flat Washers (not included).
 - d. **Qty. 12:** 3/8" Spring Washers (not included).
 - e. **Qty. 12:** 3/8" Hex Nuts (not included).
1. Carefully measure the width and length of the Trailer frame. Cut the 3/4" plywood to match the dimensions of the Trailer frame as shown in Figure K.
 2. Drill three evenly spaced, 3/8" diameter mounting holes in the inner flange of each side of the Trailer frame. Then, drill three corresponding 3/8" diameter holes in each side of the plywood.

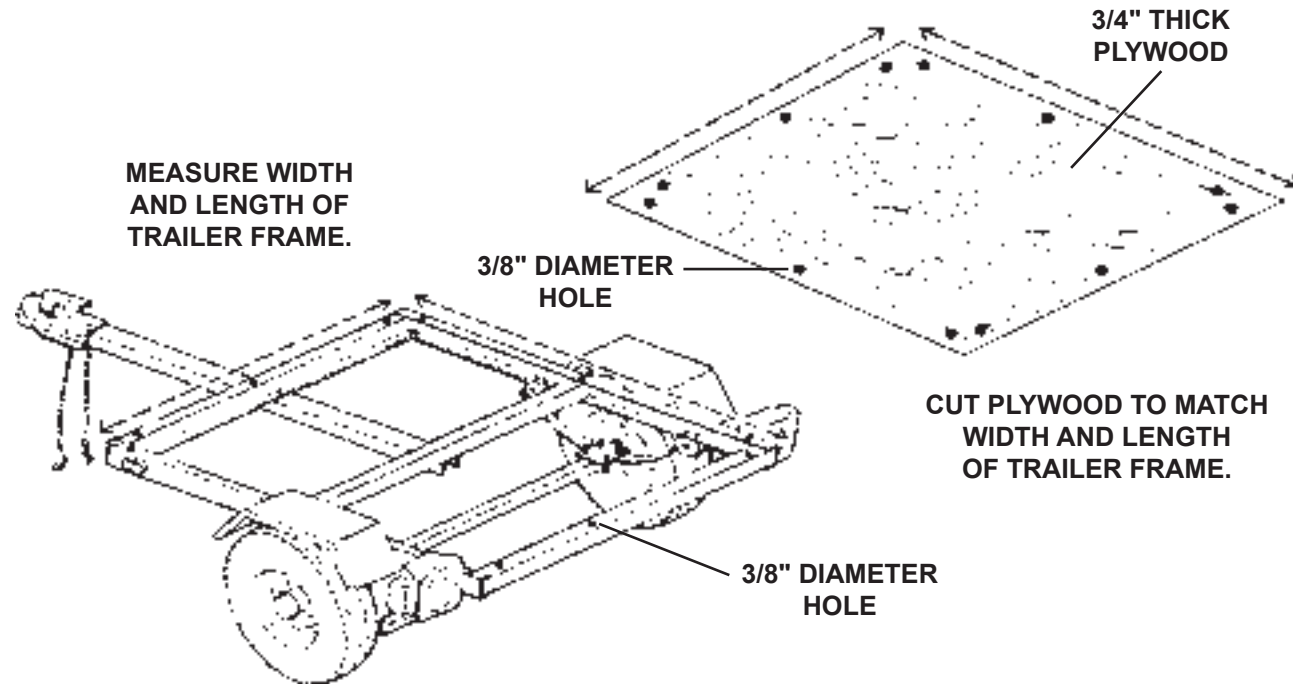

Figure K: Plywood Dimensions and Hole Locations

3. With assistance, place the cut 3/4" plywood on the Trailer frame and align the pre-drilled 3/8" holes in the plywood with the pre-drilled 3/8" mounting holes in the Trailer frame.
4. Use 3/8" Cross Head Bolts, 3/8" Flat Washers, 3/8" Spring Washers, and 3/8" Hex Nuts to secure the plywood bed to the Trailer frame.

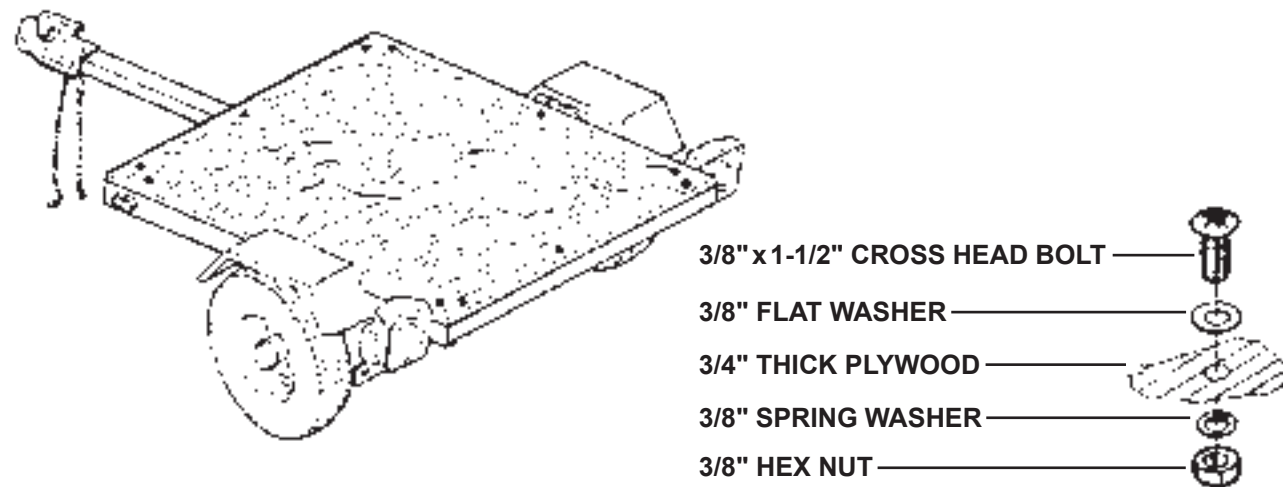

Figure L: Bed Installation

Specifications

Maximum Capacity Payload	1090 lb.
Bed Dimensions	48" x 40.5"
Hitch Ball Size	1-7/8"
Wheel Rim Diameter/Width	12-3/4" x 4-3/4"
Lug Nuts	4 Per Wheel , 85–90 ft. lb. Torque Requirement
Tire Size	4.80–12
Required Tire Air Pressure	60 PSI, Cold
Hitch Class	I

Operating Instructions



Read the **ENTIRE IMPORTANT SAFETY INFORMATION** section at the beginning of this manual including all text under subheadings therein before set up or use of this Trailer.

Before each use

1. Check Tire condition and air pressure.
2. Make sure wheel lug nuts/bolts are properly tightened.
3. Make sure hitch, coupler, tow bar, and other equipment that connect the trailer and the tow vehicle are properly secured and adjusted.
4. Make sure wiring is properly connected — not touching the road, but loose enough to make turns without disconnecting or damaging the wires.
5. Make sure all running lights, brake lights, turn signals, and hazard lights are working.
6. Check that all items are securely fastened on and in the Trailer.
7. Be sure the trailer jack, tongue support, and any attached stabilizers are raised and locked in place.
8. Check load distribution to make sure the tow vehicle and Trailer are properly balanced front to back and side to side.
9. Check side- and rear-view mirrors to make sure you have good visibility.
10. Check routes and restrictions on bridges and tunnels.
11. Make sure you have wheel chocks and jack stands.
12. Check Trailer for loose bolts and nuts, structural cracks and bends, and any other condition that may affect its safe operation. Do not use the Trailer if even minor damage appears.

Connection

WARNING! Only use a 1-7/8" ball hitch (not included) on the towing vehicle.

1. To reduce friction between the hitch ball and Hitch Coupler, apply a thin layer of heavy weight grease over the hitch ball.
2. Unlock the Coupler Trigger by removing its R-Clip and Locking Pin.
3. Pull up on the Trigger and lift up on the Handle.

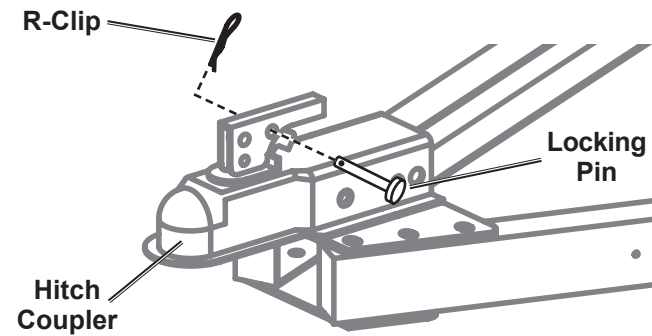

Figure M: Remove R-Clip and Locking Pin

Connection (continued)

1. With assistance, place the Hitch Coupler over the vehicle's hitch ball, pull back on the Trigger and push down on the Handle until the Trigger locks in the slot.

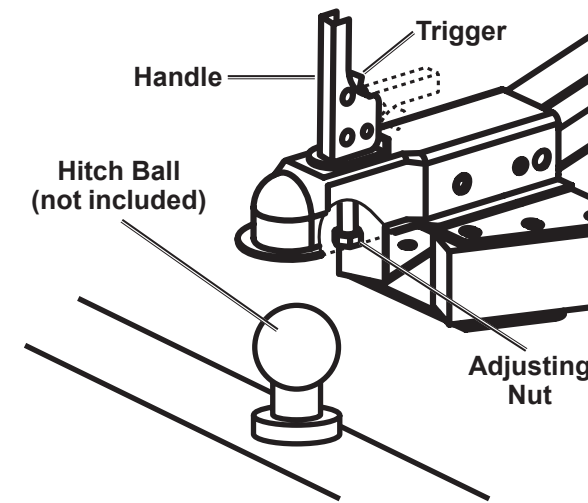

Figure N: Ball Connection

2. Pull up and down on the Coupler to make sure the hitch ball fits snugly in the Coupler. There must be no play between the hitch ball and Coupler. **WARNING!** If there is play, tighten the Adjusting Nut until no play is present. After unlocking the Handle, press back on the nut retaining plate (holding the Adjusting Nut in place) while the Nut is tightened. After the Nut is tightened, **the retaining plate must fit in place against the flats of the Nut to prevent it from moving.** This adjustment should be done by two people. If the Adjusting Nut is too tight, the Handle will not lock.

3. After the Adjusting Nut is properly adjusted, pull back on the Trigger and push down on the Handle until the Trigger locks in the slot. **Pull up on the Handle firmly** to make sure the Trigger is locked in place and the Handle cannot move. **Replace the Locking Pin and R-Clip.**

4. Attach the Safety Chain (1) to the towing vehicle's rear bumper or frame with equal length on each side and chains crossed under the trailer tongue. Allow just enough chain length for unrestricted turning without dragging chain on the ground.

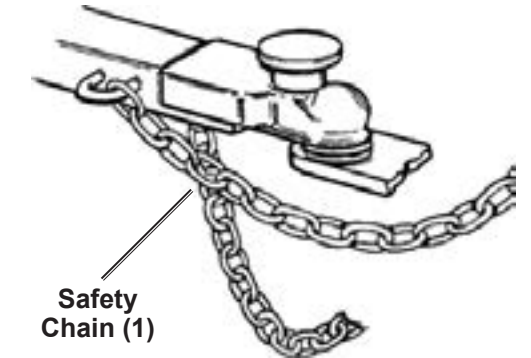

Figure O: Safety Chain

5. Connect the Wiring Harness to the towing vehicle's 12 Volt DC system.

Note: Consult the operator's manual of the towing vehicle for proper connection instructions.

6. When towing Trailer over long distances, stop and check the tightness of all connections, Side Running Lights, and Tail Lights *at least* every 100 miles.
7. Carry emergency flares and fire extinguisher, if required for operation in your state. Carry extra bulbs and fuses if towing the Trailer at night over long distances.

Tire Information

Tire Terminology Glossary

- **Accessory weight means**- the combined weight of automatic transmission, power steering, power brakes, power windows, power seats, radio, and heater, to the extent that these items are available as factory-installed equipment.
- **Carcass means**- the tire structure except for the tread which provides the major portion of the tire's capability to deflect in response to the vertical loads and tractive forces that the tire transmits from the roadway to the non-pneumatic rim, the wheel center member, or the vehicle and which attaches to the vehicle or attaches, either integrally or separably, to the wheel center member or non-pneumatic rim.
- **Carcass separation means**- the pulling away of the carcass from the non-pneumatic rim or wheel center member.
- **Chunking means**- the breaking away of pieces of the carcass or tread.
- **Cracking means**- any parting within the carcass, tread, or any components that connect the tire to the wheel center member.
- **Curb weight means**- the weight of a motor vehicle with standard equipment including the maximum capacity of fuel, oil, and coolant, and, if so equipped, air conditioning and additional weight optional engine. Load rating means- the maximum load a tire is rated to carry.
- **Maximum loaded vehicle weight means**- the sum of:
 - a. Curb weight;
 - b. Accessory weight;
 - c. Vehicle capacity weight; and
 - d. Production options weight.
- **Maximum tire width means**- the greater of either the linear distance between the exterior edges of the carcass or the linear distance between the exterior edges of the tread, both being measured parallel to the rolling axis of the tire.
- **Normal occupant weight means**- 68 kilograms times the number of occupants.
- **Occupant distribution means**- distribution of occupants in a vehicle.
- **Production options weight means**- the combined weight of those installed regular production options weighing over 2.3 kilograms in excess of those standard items which they replace, not previously considered in curb weight or accessory weight, including heavy duty brakes, ride levelers, roof rack, heavy duty battery, and special trim.
- **Tread means**- that portion of the tire that comes in contact with the road.
- **Tread separation means**- pulling away of the tread from the carcass.
- **Vehicle capacity weight means**- the rated cargo and luggage load plus 68 kilograms times the vehicle's designated seating capacity.
- **Vehicle maximum load on the tire means**- that load on an individual tire that is determined by distributing to each axle its share of the maximum loaded vehicle weight and dividing by two.
- **Vehicle normal load on the tire means**- that load on an individual tire that is determined by distributing to each axle its share of the curb weight, accessory weight, and normal occupant weight and dividing by 2.

Tire Markings

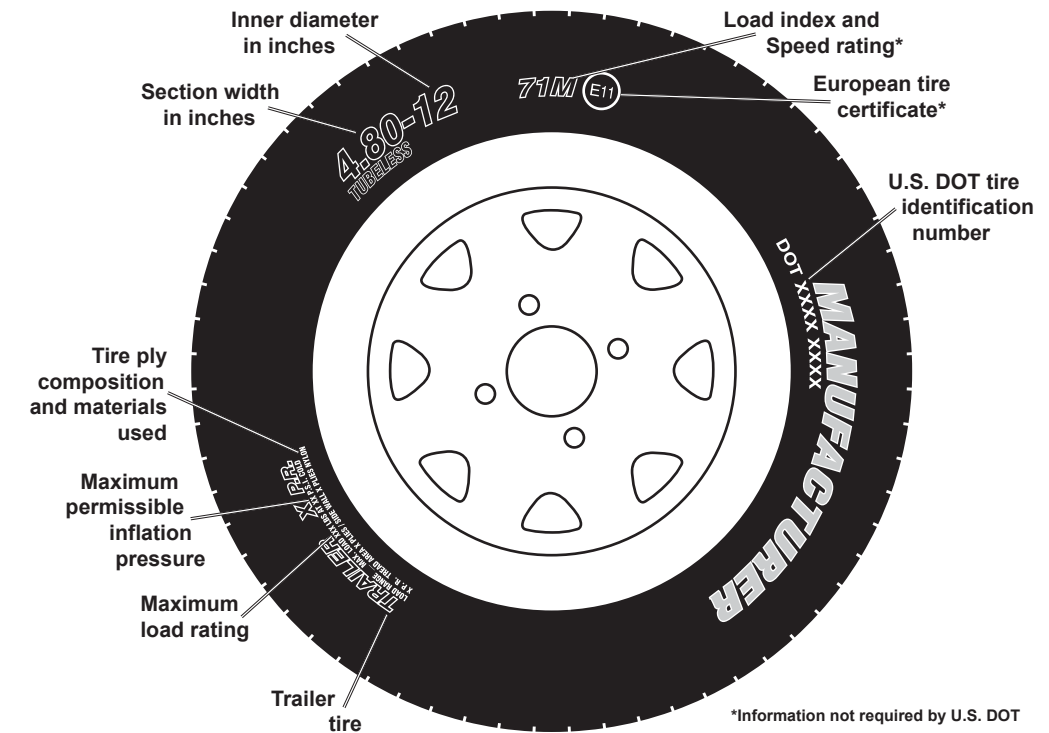

- **Section width**- This number gives the width of the tire in inches. The larger the number, the wider the tire. (The markings on the example tire diagram show 4.80. The markings on your tire may differ.)
- **Inner diameter**- This number gives the inner diameter of the tire in inches. This is also the rim diameter in inches. (The markings on the example tire diagram show 12. The markings on your tire may differ.)
- **U.S. DOT tire identification number**- This begins with the letters "DOT" and indicates that the tire meets all federal standards. The next two numbers or letters are the plant code where it was manufactured, and the last four numbers represent the week and year that the tire was built. For example, the numbers 2107 mean the 21st week of 2007. Any other numbers used are marketing codes used at the manufacturer's discretion. This information is used to contact consumers if a tire defect requires a recall.

Tire Markings (continued)

- **Maximum Load Rating**- This number indicates the maximum load in kilograms and pounds that can be carried by the tire.
- **Load index**- This is a measurement of how much weight each tire can support. See chart below. (The markings on the example tire diagram show 71. The markings on your tire may differ.)

Note: You may not find this information on all tires because it is not required by law.

Code	Pounds	Code	Pounds	Code	Pounds	Code	Pounds	Code	Pounds
71	761	79	963	87	1,201	95	1,521	103	1,929
72	783	80	992	88	1,235	96	1,565	104	1,984
73	805	81	1,019	89	1,279	97	1,609	105	2,039
74	827	82	1,047	90	1,323	98	1,653	106	2,094
75	853	83	1,074	91	1,356	99	1,709	107	2,149
76	882	84	1,102	92	1,389	100	1,764	108	2,205
77	908	85	1,135	93	1,433	101	1,819	109	2,271
78	937	86	1,168	94	1,477	102	1,874	110	2,337

Table A: Load Index Rating Codes

- **Speed Rating**- The speed rating denotes the speed at which a tire is designed to be driven for extended periods of time. *This does not indicate that the vehicle or rims can safely reach or maintain that speed.* These ratings are listed below. (The markings on the example tire diagram show M. The markings on your tire may differ. Note: You may not find this information on all tires because it is not required by law.

Code	MPH	Code	MPH	Code	MPH
F	50	N	87	U	124
G	56	P	94	H	130
J	62	Q	100	V	149
K	68	R	106	Z	149
L	75	S	112	W	168
M	81	T	118	Y	186

Table B: Tire Speed Rating Codes

- **Tire Ply Composition and Materials Used**- The number of plies indicates the number of layers of rubber-coated fabric in the tire. In general, the greater the number of plies, the more weight a tire can support. Tire manufacturers also must indicate the materials in the tire, which include steel, nylon, polyester, and others.
- **Maximum Permissible Inflation Pressure**- This number is the greatest amount of air pressure that should ever be put in the tire under normal driving conditions.

Tire Inflation and Load Limit

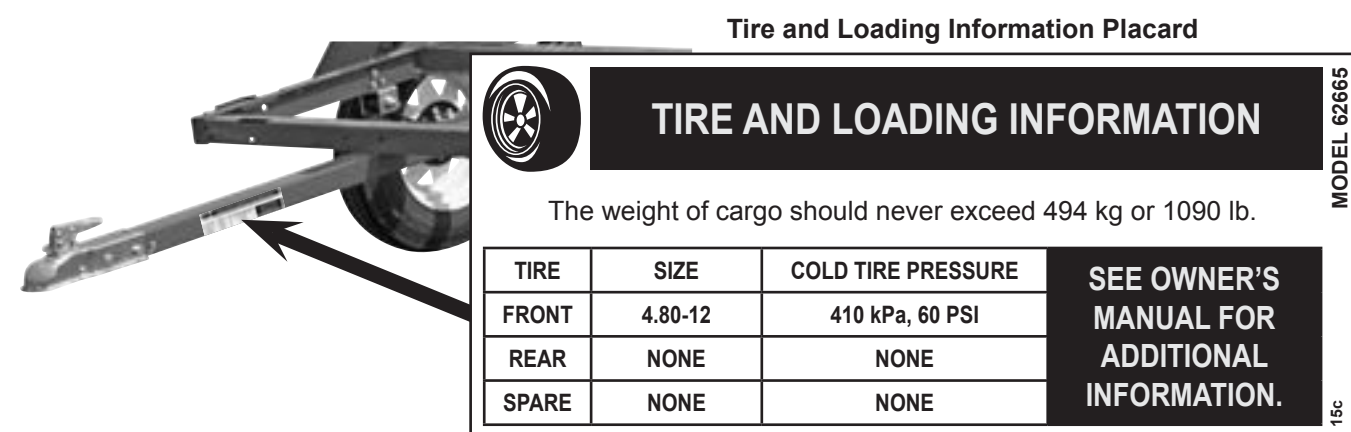

Figure P: Tire and Loading Information Placard Location

The Tire and Loading Information Placard displays the cold tire inflation pressure and the load limit for this vehicle. See the Tire Care section starting on the following page for an explanation of tire pressure and see the Vehicle Load Limit following that for an explanation of load limit.

Tire Care

Checking Tire Pressure

Note: Underinflated tires can decrease handling, stopping performance, traction, tire life, and load-carrying capability, in addition to causing other negative and hazardous effects, including tire failure. Overinflated tires are at greater risk of an impact break, where the tread and casing break when striking a hard edge, often opening a huge gash across the tread. Incorrect inflation pressure also increases tires wear rate. Therefore, it is important to keep tires inflated properly.

Check all tires' pressure at least monthly, due to the following factors:

- Most tires naturally lose air gradually.
- Tires can suddenly lose air if the tire strikes a pothole, curb, or other object.
- It is usually not possible to determine underinflation of radial tires by visual inspection.

This vehicle has 60 PSI recommended cold tire inflation pressure. The term "cold" in this manual does not refer to the temperature outside, but it refers to the fact that a tire that has not been driven for a period is cooler (and therefore has lower pressure) than a tire that has been driven on. Tires heat up while being

driven on. To check (or fill to) a tire's cold inflation, the tire must have not been driven for more than a mile or two for at least three hours. If you check a tires pressure when it is not "cold", the pressure will appear higher than the actual cold tire inflation.

Steps for Maintaining Proper Tire Pressure

1. Locate the recommended tire pressure on the vehicle's tire information placard, certification label, or in the owner's manual. This Trailer has 60 PSI recommended cold tire inflation pressure.
2. Measure and record the tire pressure of all tires.
3. If the tire pressure is too high in any of the tires and the tires have not been driven for at least three hours, slowly release air by gently pressing on the tire valve stem with the edge of your tire gauge until you get to the correct pressure. If the vehicle has been driven within the past three hours and the tire pressure is too high on any tires, then recheck the pressure once the tires have been allowed to sit motionless for at least three hours.
4. If the tire pressure is too low, note the difference between the measured tire pressure and the correct tire pressure. These "missing" pounds of pressure are what you will need to add.
5. At a service station, add the missing pounds of air pressure to each tire that is underinflated.
6. Check all the tires to make sure they have the same air pressure.
7. If the tires' pressure was not measured "cold", then the pressure should be rechecked with the tires cold as soon as possible.

Tire Size

To maintain safety, only purchase new tires of the same size as the original tires. Look at the Tire and Loading Information Placard, the Specifications Chart in this manual, or the sidewall of the tire being replaced. If you have any doubt about selecting the correct size, consult a tire dealer.

Tire Tread

The tire tread provides traction that prevents your vehicle from slipping, especially if the road is wet or icy. Tires are unsafe and should be replaced when the tread is worn down to 1/16". Measure tread depth using a tread depth indicator (not included).

Tire Rotation

Every 5,000 miles the left and right tires should be switched. This will cause the tires to wear more evenly and last longer.

Tire Balance and Alignment

The tires need to be balanced to prevent vibration when driving. This involves attaching small weights to the rim to offset small differences in rim and tire weight. The tires also need to be aligned properly. Alignment is the orientation of the tires to the road surface and their being parallel. This helps the tires to wear evenly, and provide better traction. Both tire balance and alignment require specialized equipment that is not provided with this vehicle.

Tire Repair

To properly repair a punctured tire, the hole needs to be properly plugged and patched from the inside of the tire. Tread punctures can be repaired if they are not too large. Sidewall punctures should not be repaired, the tire needs to be replaced if the sidewall is damaged. Tires should be removed from the rim to be inspected before being plugged and patched. A qualified mechanic should remove the tire from the rim, perform the repair, and remount the tire.

Vehicle Load Limit

Steps for Determining Correct Load Limit

1. Locate the statement "The weight of cargo should never exceed XXX kilograms or XXX pounds" on your vehicle's placard.
2. That figure equals the available amount of cargo and luggage load capacity.
3. Determine the combined weight of luggage and cargo being loaded on the vehicle. That weight may not safely exceed the available cargo and luggage load capacity.
4. If the Trailer's load exceeds the cargo and luggage load capacity, then the Trailer will be unsafe resulting in hazardous effects, such as: Trailer's tires will not be able to maintain traction properly, and stopping distance will be increased significantly.

Operation Safety

Note: Selected recommendations in this section are adapted from *TOWING A TRAILER - Being Equipped for Safety*, published by NHTSA. For full details, see that document.

1. This Trailer is not a toy. Do not allow children to play on or near this item.
2. Take time to practice before driving on main roads.
3. Never allow anyone to ride in or on the trailer.
4. Do not transport animals in this trailer.

General Handling

1. Use the driving gear that the towing vehicle manufacturer recommends for towing.
2. Drive at moderate speeds. This will place less strain on your tow vehicle and trailer. Trailer instability (sway) is more likely to occur as speed increases. **Do not exceed 45 miles per hour when towing the Trailer.**
3. Avoid sudden stops and starts that can cause skidding, sliding, or jackknifing.
4. Avoid sudden steering maneuvers that might create sway or undue side force on the trailer.
5. Slow down when traveling over bumpy roads, railroad crossings, and ditches.
6. Make wider turns at curves and corners. Because your trailer's wheels are closer to the inside of a turn than the wheels of your tow vehicle, they are more likely to hit or ride up over curbs.
7. To control swaying caused by air pressure changes and wind buffeting when larger vehicles pass from either direction, release the accelerator pedal to slow down and keep a firm grip on the steering wheel.

Braking

1. Allow considerably more distance for stopping.
2. If you have an electric trailer brake controller and excessive sway occurs, activate the trailer brake controller by hand. Do not attempt to control trailer sway by applying the tow vehicle brakes; this will generally make the sway worse.
3. Always anticipate the need to slow down. To reduce speed, shift to a lower gear and press the brakes lightly.

Acceleration and Passing

1. When passing a slower vehicle or changing lanes, signal well in advance and make sure you allow extra distance to clear the vehicle before you pull back into the lane.
2. Pass on level terrain with plenty of clearance. Avoid passing on steep upgrades or downgrades.
3. If necessary, downshift for improved acceleration or speed maintenance.
4. When passing on narrow roads, be careful not to go onto a soft shoulder. This could cause your trailer to jackknife or go out of control.

Downgrades and Upgrades

1. Downshift to assist with braking on downgrades and to add power for climbing hills.
2. On long downgrades, apply brakes at intervals to keep speed in check. Never leave brakes on for extended periods of time or they may overheat.
3. Some tow vehicles have specifically calibrated transmission tow-modes. Be sure to use the tow-mode recommended by the manufacturer.

Backing Up

1. Put your hand at the bottom of the steering wheel. To turn left, move your hand left. To turn right, move your hand right.
2. Back up slowly.
3. Because mirrors cannot provide all of the visibility you may need when backing up, have someone outside at the rear of the trailer to guide you whenever possible.
4. Use slight movements of the steering wheel to adjust direction. Exaggerated movements will cause greater movement of the trailer.
5. If you have difficulty, pull forward and realign the tow vehicle and trailer and start again.

Parking

1. Try to avoid parking on grades.
 2. If possible, have someone outside to guide you as you park.
 3. **Once stopped, but before shifting into Park:**
 - a. Have someone place blocks on the downhill side of the trailer wheels.
 - b. Apply the parking brake.
 - c. Shift into Park. (first or reverse gear for manual transmissions)
 - d. Then remove your foot from the brake pedal.
 4. **Before uncoupling a trailer:**
 - a. Place blocks at the front and rear of the trailer tires to ensure that the trailer does not roll away when the coupling is released.
 - b. An unbalanced load may cause the tongue to suddenly rotate upward; therefore, before uncoupling, place jack stands under the rear of the trailer to prevent injury.
- Following this parking sequence is important to make sure your vehicle does not become locked in Park because of extra load on the transmission.

TRAILER LICENSING NOTICE

Some states may consider this Trailer a vehicle requiring registration, licensing, and titling. Check with your State Department of Motor Vehicles for information and guidance on registering, licensing, and titling the Trailer.

Maintenance



Procedures not specifically explained in this manual must be performed only by a qualified technician.

⚠️WARNING

TO PREVENT SERIOUS INJURY FROM TOOL FAILURE:

Do not use damaged equipment. If abnormal noise or vibration occurs, have the problem corrected before further use.

Note: Tow vehicles often have more frequent maintenance requirements, including changes of engine and transmission oils and filters, lubrication of components, and cooling system checks. Check your owner's manual for information on scheduled maintenance of your tow vehicle.

BEFORE EACH USE: Inspect the trailer and tow vehicle according to the instructions on page 16.

Tires

1. Periodic inspection and maintenance of tires and wheels are essential to towing safety, including spare tires. Proper tire pressure affects vehicle handling and the safety of your tires. You can find the correct tire pressure for your tow vehicle on the tire information placard.
2. Underinflation reduces the load-carrying capacity of your tow vehicle or trailer, may cause sway and control problems, and may result in overheating, causing blowouts or other tire failure.
3. Overinflation causes premature tire wear and affects the handling characteristics of the tow vehicle or trailer.

Wheel Bearings

1. **EVERY 2,000 TO 3,000 MILES OF USE,** lubricate the Hub Assemblies with a heavy weight bearing grease, following **Bearing Packing Instructions** on page .
2. After each Hub Assembly is reassembled, tighten the Castle Nut until the wheel starts spinning with slight resistance. Loosen the Castle Nut about 1/6 turn from this point.
3. Insert a new Cotter Pin through the Castle Nut and the hole in the axle.
4. Bend the Cotter Pin back, locking it and the Nut in place.

Hitch

Check the nuts, bolts, and other fasteners to ensure that the hitch remains secured to the tow vehicle and the coupler remains secured to the trailer. The connection point may require periodic lubrication to permit free movement of the coupler to the hitch ball.

Wiring

1. Make sure connector-plug prongs and receptacles, light bulb sockets, wire splices, and ground connections are clean and shielded from moisture. Lightly coat all electrical terminal connections with nonconducting (dielectric), light waterproof grease.
2. Clean the prongs with very fine sandpaper, being careful not to damage the contact area.
3. Turn lights off, then clean the surface deposits in the connector holes. Try to clean off only the deposits and lubricate lightly with dielectric, light waterproof grease.

PLEASE READ THE FOLLOWING CAREFULLY

THE MANUFACTURER AND/OR DISTRIBUTOR HAS PROVIDED THE PARTS LIST AND ASSEMBLY DIAGRAM IN THIS MANUAL AS A REFERENCE TOOL ONLY. NEITHER THE MANUFACTURER OR DISTRIBUTOR MAKES ANY REPRESENTATION OR WARRANTY OF ANY KIND TO THE BUYER THAT HE OR SHE IS QUALIFIED TO MAKE ANY REPAIRS TO THE PRODUCT, OR THAT HE OR SHE IS QUALIFIED TO REPLACE ANY PARTS OF THE PRODUCT. IN FACT, THE MANUFACTURER AND/OR DISTRIBUTOR EXPRESSLY STATES THAT ALL REPAIRS AND PARTS REPLACEMENTS SHOULD BE UNDERTAKEN BY CERTIFIED AND LICENSED TECHNICIANS, AND NOT BY THE BUYER. THE BUYER ASSUMES ALL RISK AND LIABILITY ARISING OUT OF HIS OR HER REPAIRS TO THE ORIGINAL PRODUCT OR REPLACEMENT PARTS THERETO, OR ARISING OUT OF HIS OR HER INSTALLATION OF REPLACEMENT PARTS THERETO.

Parts List and Diagram

Parts List

Part	Description	Qty
1	7/32" Safety Chain	1
2	1-7/8" Coupler	1
3	Tow Bar	1
4	Axle	1
5	3 Leaf Spring	2
6	Hex M12x80	4
7	Spring Plate	2
8	U Bolt M10x90	4
9	Hub Ass'y	2
10	Bearing	4
11	Flat Washer	2
12	Castle Nut	2
13	Dust Cap	2
14	Cotter Pin	2
15	4.80-12" Tire/Wheel Assembly	2

Part	Description	Qty
16	Grease Seal	2
17	Lug Nut	8
18	Fender	2
19	Left Tail Light	1
20	Spring Hanger	4
21	Left Side Rail	1
22	Cross Member	3
23	Right Side Rail	1
24	Right Tail Light (W Harness)	1
25	Licence Plate Bracket	1
26	Light Bracket	2
27	Hex M10x20	32
28	Side Running Light	2
29	M10x85 Nut	2
30	Locking Pin & R-Clip	1 Kit

Assembly Diagram

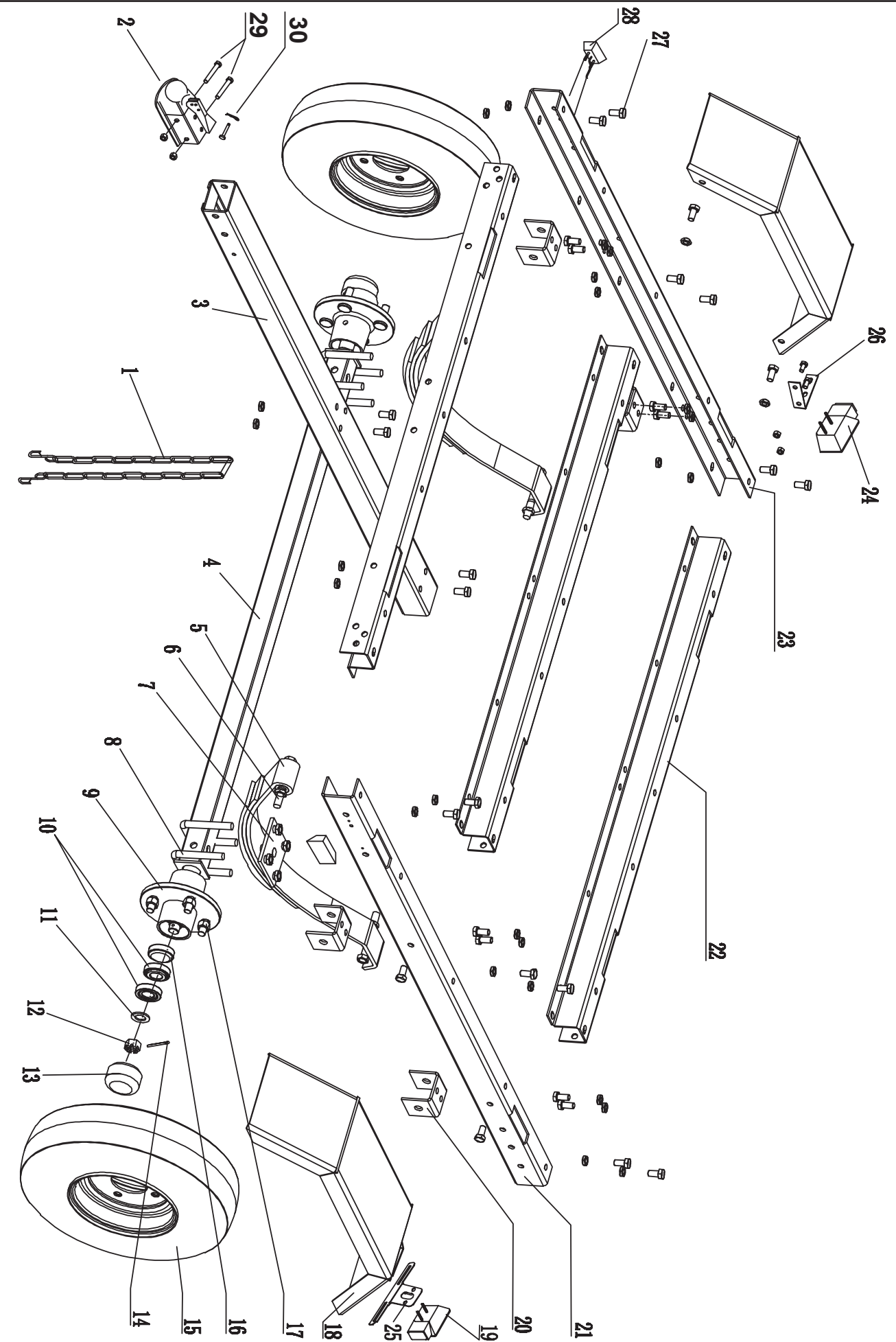

Record Product's Serial Number Here: _____

Note: If product has no serial number, record month and year of purchase instead.

Note: Some parts are listed and shown for illustration purposes only, and are not available individually as replacement parts.

Reporting Safety Defects

If you believe that your vehicle has a defect which could cause a crash or could cause injury or death, you should immediately inform the National Highway Traffic Safety Administration (NHTSA) in addition to notifying Jinhua Yongqiang Vehicles Factory. If NHTSA receives similar complaints, it may open an investigation. And if it finds that a safety defect exists in a group of vehicles, it may order a recall and remedy campaign. However, NHTSA cannot become involved in individual problems between you, your dealer, or Jinhua Yongqiang Vehicles Factory. To contact NHTSA, you may either call the Auto Safety Hotline toll-free at 1-888-327-4236 or 202-366-4000 or write to NHTSA, 1200 New Jersey Avenue, SE, West Building, Washington, DC 20590. You can also obtain other information about motor vehicle safety from the Hotline.

Note: Check with your local Department of Motor Vehicles for registration procedures. Some DMV's require the Certificate of Origin to be notarized, others do not.

Limited 90 Day Warranty

Harbor Freight Tools Co. makes every effort to assure that its products meet high quality and durability standards, and warrants to the original purchaser that this product is free from defects in materials and workmanship for the period of 90 days from the date of purchase. This warranty does not apply to damage due directly or indirectly, to misuse, abuse, negligence or accidents, repairs or alterations outside our facilities, criminal activity, improper installation, normal wear and tear, or to lack of maintenance. We shall in no event be liable for death, injuries to persons or property, or for incidental, contingent, special or consequential damages arising from the use of our product. Some states do not allow the exclusion or limitation of incidental or consequential damages, so the above limitation of exclusion may not apply to you. THIS WARRANTY IS EXPRESSLY IN LIEU OF ALL OTHER WARRANTIES, EXPRESS OR IMPLIED, INCLUDING THE WARRANTIES OF MERCHANTABILITY AND FITNESS.

To take advantage of this warranty, the product or part must be returned to us with transportation charges prepaid. Proof of purchase date and an explanation of the complaint must accompany the merchandise. If our inspection verifies the defect, we will either repair or replace the product at our election or we may elect to refund the purchase price if we cannot readily and quickly provide you with a replacement. We will return repaired products at our expense, but if we determine there is no defect, or that the defect resulted from causes not within the scope of our warranty, then you must bear the cost of returning the product.

This warranty gives you specific legal rights and you may also have other rights which vary from state to state.

