

Owner's Manual & Safety Instructions

Save This Manual Keep this manual for the safety warnings and precautions, assembly, operating, inspection, maintenance and cleaning procedures. Write the product's serial number in the back of the manual near the assembly diagram (or month and year of purchase if product has no number). Keep this manual and the receipt in a safe and dry place for future reference.

24K

CENTRAL MACHINERY

7" X 12" METAL CUTTING BANDSAW



63469

Visit our website at: <https://www.harborfreight.com>
Email our technical support at: productsupport@harborfreight.com

When unpacking, make sure that the product is intact and undamaged. If any parts are missing or broken, please call 1-800-444-3353 as soon as possible.

⚠️ WARNING

Read this material before using this product. Failure to do so can result in serious injury. **SAVE THIS MANUAL.**





Copyright© 2024 by Harbor Freight Tools®. All rights reserved.
No portion of this manual or any artwork contained herein may be reproduced in any shape or form without the express written consent of Harbor Freight Tools. Diagrams within this manual may not be drawn proportionally. Due to continuing improvements, actual product may differ slightly from the product described herein. Tools required for assembly and service may not be included.

Table of Contents

Safety	3	Maintenance	18
Specifications	6	Parts List and Diagram	22
Setup	7	Warranty	32
Operation.....	9		

CENTRAL MACHINERY

WARNING SYMBOLS AND DEFINITIONS

	This is the safety alert symbol. It is used to alert you to potential personal injury hazards. Obey all safety messages that follow this symbol to avoid possible injury or death.
	Indicates a hazardous situation which, if not avoided, will result in death or serious injury.
	Indicates a hazardous situation which, if not avoided, could result in death or serious injury.
	Indicates a hazardous situation which, if not avoided, could result in minor or moderate injury.
	Addresses practices not related to personal injury.

SAFETY

SETUP

OPERATION

MAINTENANCE

IMPORTANT SAFETY INFORMATION

General Tool Safety Warnings

⚠ WARNING

Read all safety warnings and instructions.

Failure to follow the warnings and instructions may result in electric shock, fire and/or serious injury.

Save all warnings and instructions for future reference.

1. KEEP GUARDS IN PLACE and in working order.
2. REMOVE ADJUSTING KEYS AND WRENCHES. Form habit of checking to see that keys and adjusting wrenches are removed from tool before turning it on.
3. KEEP WORK AREA CLEAN. Cluttered areas and benches invite accidents.
4. DON'T USE IN DANGEROUS ENVIRONMENT. Don't use power tools in damp or wet locations, or expose them to rain. Keep work area well lighted.
5. KEEP CHILDREN AWAY. All visitors should be kept safe distance from work area.
6. MAKE WORKSHOP KID PROOF with padlocks, master switches, or by removing starter keys.
7. DON'T FORCE TOOL. It will do the job better and safer at the rate for which it was designed.
8. USE RIGHT TOOL. Don't force tool or attachment to do a job for which it was not designed.
9. USE PROPER EXTENSION CORD. Make sure your extension cord is in good condition. When using an extension cord, be sure to use one heavy enough to carry the current your product will draw. An undersized cord will cause a drop in line voltage resulting in loss of power and overheating. Table A shows the correct size to use depending on cord length and nameplate ampere rating. If in doubt, use the next heavier gauge. The smaller the gauge number, the heavier the cord.
10. WEAR PROPER APPAREL. Do not wear loose clothing, gloves, neckties, rings, bracelets, or other jewelry which may get caught in moving parts. Nonslip footwear is recommended. Wear protective hair covering to contain long hair.
11. ALWAYS USE SAFETY GLASSES. Also use face or dust mask if cutting operation is dusty. Everyday eyeglasses only have impact resistant lenses, they are NOT safety glasses.
12. SECURE WORK. Use clamps or a vise to hold work when practical. It's safer than using your hand and it frees both hands to operate tool.
13. DON'T OVERREACH. Keep proper footing and balance at all times.
14. MAINTAIN TOOLS WITH CARE. Keep tools sharp and clean for best and safest performance. Follow instructions for lubricating and changing accessories.
15. DISCONNECT TOOLS before servicing; when changing accessories, such as blades, bits, cutters, and the like.
16. REDUCE THE RISK OF UNINTENTIONAL STARTING. Make sure switch is in off position before plugging in.
17. USE RECOMMENDED ACCESSORIES. Consult the owner's manual for recommended accessories. The use of improper accessories may cause risk of injury to persons.
18. NEVER STAND ON TOOL. Serious injury could occur if the tool is tipped or if the cutting tool is unintentionally contacted.
19. CHECK DAMAGED PARTS. Before further use of the tool, a guard or other part that is damaged should be carefully checked to determine that it will operate properly and perform its intended function – check for alignment of moving parts, binding of moving parts, breakage of parts, mounting, and any other conditions that may affect its operation. A guard or other part that is damaged should be properly repaired or replaced.
20. NEVER LEAVE TOOL RUNNING UNATTENDED. TURN POWER OFF. Don't leave tool until it comes to a complete stop.

Table A: RECOMMENDED MINIMUM WIRE GAUGE FOR EXTENSION CORDS (115-250 VOLT)

NAMEPLATE AMPERES (at full load)	EXTENSION CORD LENGTH			
	25' 50'	50' 100'	100' 200'	150' 300'
0 – 6	18	16	16	14
6.1 – 10	18	16	14	12
10.1 – 12	16	16	14	12
12.1 – 16	14	12	Do not use.	

Grounding Instructions

SAFETY

SETUP

OPERATION

MAINTENANCE



⚠️ WARNING

TO PREVENT ELECTRIC SHOCK AND DEATH FROM INCORRECT GROUNDING WIRE CONNECTION READ AND FOLLOW THESE INSTRUCTIONS:

110-120 VAC Grounded Tools: Tools with Three Prong Plugs

1. In the event of a malfunction or breakdown, grounding provides a path of least resistance for electric current to reduce the risk of electric shock. This tool is equipped with an electric cord having an equipment-grounding conductor and a grounding plug. The plug must be plugged into a matching outlet that is properly installed and grounded in accordance with all local codes and ordinances.
2. Do not modify the plug provided – if it will not fit the outlet, have the proper outlet installed by a qualified electrician.
3. Improper connection of the equipment-grounding conductor can result in a risk of electric shock. The conductor with insulation having an outer surface that is green with or without yellow stripes is the equipment-grounding conductor. If repair or replacement of the electric cord or plug is necessary, do not connect the equipment-grounding conductor to a live terminal.
4. Check with a qualified electrician or service personnel if the grounding instructions are not completely understood, or if in doubt as to whether the tool is properly grounded.
5. Use only 3-wire extension cords that have 3-prong grounding plugs and 3-pole receptacles that accept the tool's plug.

6. Repair or replace damaged or worn cord immediately.

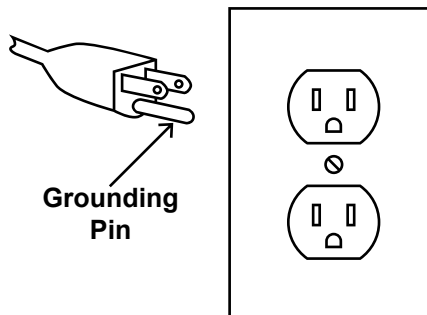

**125 VAC 3-Prong Plug and Outlet
(for up to 125 VAC and up to 15 A)**

7. This tool is intended for use on a circuit that has an outlet that looks like the one illustrated above in **125 VAC 3-Prong Plug and Outlet**. The tool has a grounding plug that looks like the plug illustrated above in **125 VAC 3-Prong Plug and Outlet**.
8. The outlet must be properly installed and grounded in accordance with all codes and ordinances.
9. Do not use an adapter to connect this tool to a different outlet.

220-240 VAC Tools

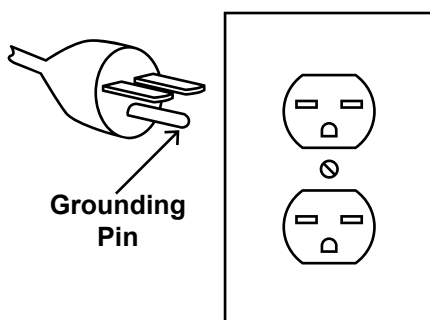

**250 VAC 3-Prong Plug and Outlet
(for up to 250 VAC and up to 15 A)**

1. This tool is intended for use on a circuit that has an outlet that looks like the one illustrated above in **250 VAC 3-Prong Plug and Outlet**. The tool has a grounding plug that looks like the plug illustrated above in **250 VAC 3-Prong Plug and Outlet**. Make sure the tool is connected to an outlet

having the same configuration as the plug. No adapter is available or should be used with this tool. If the tool must be reconnected for use on a different type of electric circuit, the reconnection should be made by qualified service personnel; and after reconnection, the tool should comply with all local codes and ordinances.

2. The 250 VAC plug does not come pre-installed and will need to be installed by a certified electrician.
3. The plug above is for use on a 15 A circuit. A different 250 VAC plug and outlet combination may be used, provided it is rated to handle the electrical requirements of the tool and is installed by a certified electrician.

Band Saw Safety Warnings

For Your Own Safety Read Instruction Manual Before Operating Saw

1. Wear eye protection.
2. Do not remove jammed cutoff pieces until blade has stopped.
3. Maintain proper adjustment of blade tension, blade guides, and thrust bearings.
4. Adjust upper guide to just clear workpiece.
5. Hold workpiece firmly against table.
6. Properly adjust the upper blade guide, blade tension and blade guide bearings before each use to reduce the risk of injury. See Operating Instructions for explanation of needed adjustments.
7. Use special care when unpacking or replacing bandsaw blade. Blade can be under tension and may suddenly uncoil. Wear ANSI-approved safety glasses under a full face shield and heavy-duty work gloves.
8. Place the Band Saw on a flat, level, sturdy surface capable of supporting the weight of the Saw and workpieces. "Chock" the Wheels to prevent the Band Saw from accidentally moving.
9. Before using the Band Saw, confirm the Saw Blade is properly mounted and is not cracked or bent.
10. Do not cut more than one workpiece at a time.
11. When cutting a large workpiece, support its entire length properly. If necessary, use a roller stand (not included).
12. Do not lean on the Band Saw when the tool is in its upright position.
13. When moving the Band Saw, pivot its head to the horizontal position.
14. Bring the Saw Blade to full rotational speed before feeding a workpiece into the Blade. When turning off the Band Saw, allow the Saw Blade to spin down and stop on its own. Do not press against the Saw Blade to stop it.
15. Wear heavy-duty work gloves when changing the Saw Blade.
16. Turn off the Band Saw and allow the Saw Blade to completely stop if the Saw Blade is to be backed out of an uncompleted cut.
17. Use indoors only.
18. If the teeth of the Saw Blade are so far apart that they straddle the workpiece, severe damage to the workpiece and/or Saw Blade will result.
19. **DO NOT OPERATE WITH ANY GUARD DISABLED, DAMAGED, OR REMOVED. Moving guards must move freely and close instantly.**
20. The use of accessories or attachments not recommended by the manufacturer may result in a risk of injury to persons.
21. When servicing use only identical replacement parts.
22. Only use safety equipment that has been approved by an appropriate standards agency. Unapproved safety equipment may not provide adequate protection. Eye protection must be ANSI-approved and breathing protection must be NIOSH-approved for the specific hazards in the work area.
23. Stay alert, watch what you are doing and use common sense when operating a power tool. Do not use a power tool while you are tired or under the influence of drugs, alcohol or medication. A moment of inattention while operating power tools may result in serious personal injury.
24. Industrial applications must follow OSHA guidelines.
25. Maintain labels and nameplates on the tool. These carry important safety information. If unreadable or missing, contact Harbor Freight Tools for a replacement.
26. Avoid unintentional starting. Prepare to begin work before turning on the tool.
27. People with pacemakers should consult their physician(s) before use. Electromagnetic fields in close proximity to heart pacemaker could cause pacemaker interference or pacemaker failure.
28. The warnings, precautions, and instructions discussed in this instruction manual cannot cover all possible conditions and situations that may occur. It must be understood by the operator that common sense and caution are factors which cannot be built into this product, but must be supplied by the operator.

Vibration Safety

SAFETY

This tool vibrates during use. Repeated or long-term exposure to vibration may cause temporary or permanent physical injury, particularly to the hands, arms and shoulders. To reduce the risk of vibration-related injury:

1. Anyone using vibrating tools regularly or for an extended period should first be examined by a doctor and then have regular medical check-ups to ensure medical problems are not being caused or worsened from use. Pregnant women or people who have impaired blood circulation to the hand, past hand injuries, nervous system disorders, diabetes, or Raynaud's Disease should not use this tool. If you feel any medical or physical symptoms related to vibration (such as tingling, numbness, and white or blue fingers), seek medical advice as soon as possible.
2. Do not smoke during use. Nicotine reduces the blood supply to the hands and fingers, increasing the risk of vibration-related injury.
3. Use tools with the lowest vibration when there is a choice between different processes.
4. Include vibration-free periods each day of work.
5. Grip workpiece as lightly as possible (while still keeping safe control of it). Let the tool do the work.
6. To reduce vibration, maintain the tool as explained in this manual. If any abnormal vibration occurs, stop use immediately.



SAVE THESE INSTRUCTIONS.

SETUP

OPERATION

MAINTENANCE

Specifications

Electrical Rating	115VAC / 60Hz / 12A As wired from the manufacturer. See pages page 29 - 31 for additional wiring options that only a licensed electrician should attempt. (230VAC / 60Hz / 6A wiring possible)
Motor No Load Speed	1720 RPM
Blade Speeds	90 / 135 / 195 / 255 FPM
Cutting Capacity	7" Round Stock 7" x 12" Rectangular Stock
V-Belt Type	3V-270
Blade Size	93" L x .75" W x 0.031" Thick / 6 TPI

Setup - Before Use:



Read the **ENTIRE IMPORTANT SAFETY INFORMATION** section at the beginning of this manual including all text under subheadings therein before set up or use of this product.

WARNING

TO PREVENT SERIOUS INJURY FROM ACCIDENTAL OPERATION:

Turn the Power Switch of the tool off and unplug the tool from its electrical outlet before performing any procedure in this section.

Note: For additional information regarding the parts listed in the following pages, refer to the Assembly Diagram near the end of this manual.

Assembly/Mounting

WARNING! TO PREVENT SERIOUS INJURY:

To assemble and locate the Bandsaw will require additional assistance and a proper lifting device.

1. After the Bandsaw and its accessories are unpacked, make sure its Head is lowered to its horizontal position.
2. With a proper lifting device, raise the Bandsaw approximately six inches off the floor surface.
3. Once the Bandsaw is lifted, insert the Wheel Rod (92-4) through the two holes located at the bottom/right side of the Stand (77S). Slide one Wheel (92-2) on each end of the Wheel Rod. Place one Washer (92-1) on each end of the Wheel Rod. Insert one Cotter Pin (92-3) through the hole in each end of the Wheel Rod. Make sure to bend the Cotter Pins to secure the Wheels in place.

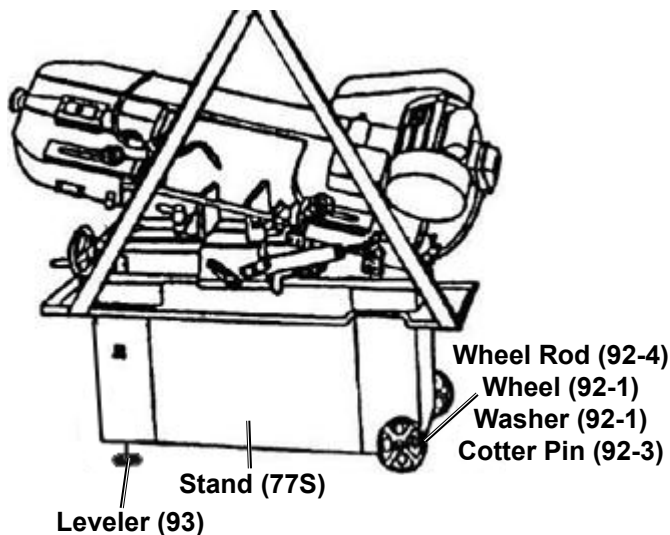

4. Screw in the two Levelers (93) into the two threaded mounting holes located underneath the bottom/left side of the Stand.
5. Carefully lower the Bandsaw to the floor surface. Then turn the two Levelers clockwise or counterclockwise to properly level the Stand.
6. Attach the Hand Rod (98-1) to the Stand Assembly using 4 Screws (98-2), 8 Washers (98-3) and 4 Nuts (98-4).

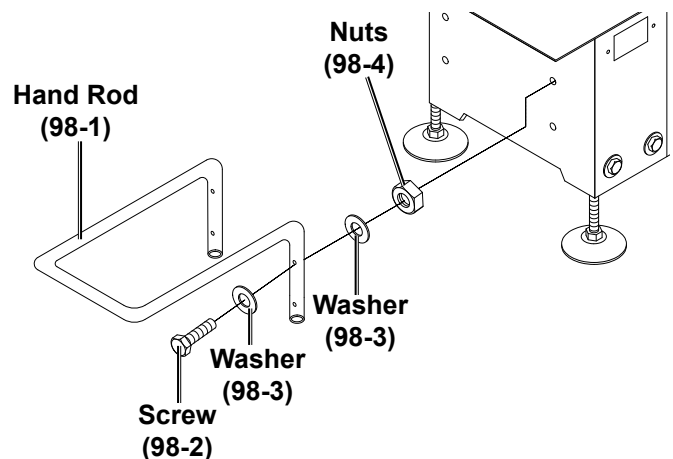

NOTE: The Bandsaw is factory pre-wired to operate on a grounded, 115 volt, 60 Hz, 1-Phase system. See pages page 29 - 31 for additional wiring options that only a licensed electrician should attempt. **WARNING! TO PREVENT SERIOUS INJURY: Only a licensed electrician should attempt to rewire the Bandsaw.**

Functions

SAFETY

SETUP

OPERATION

MAINTENANCE

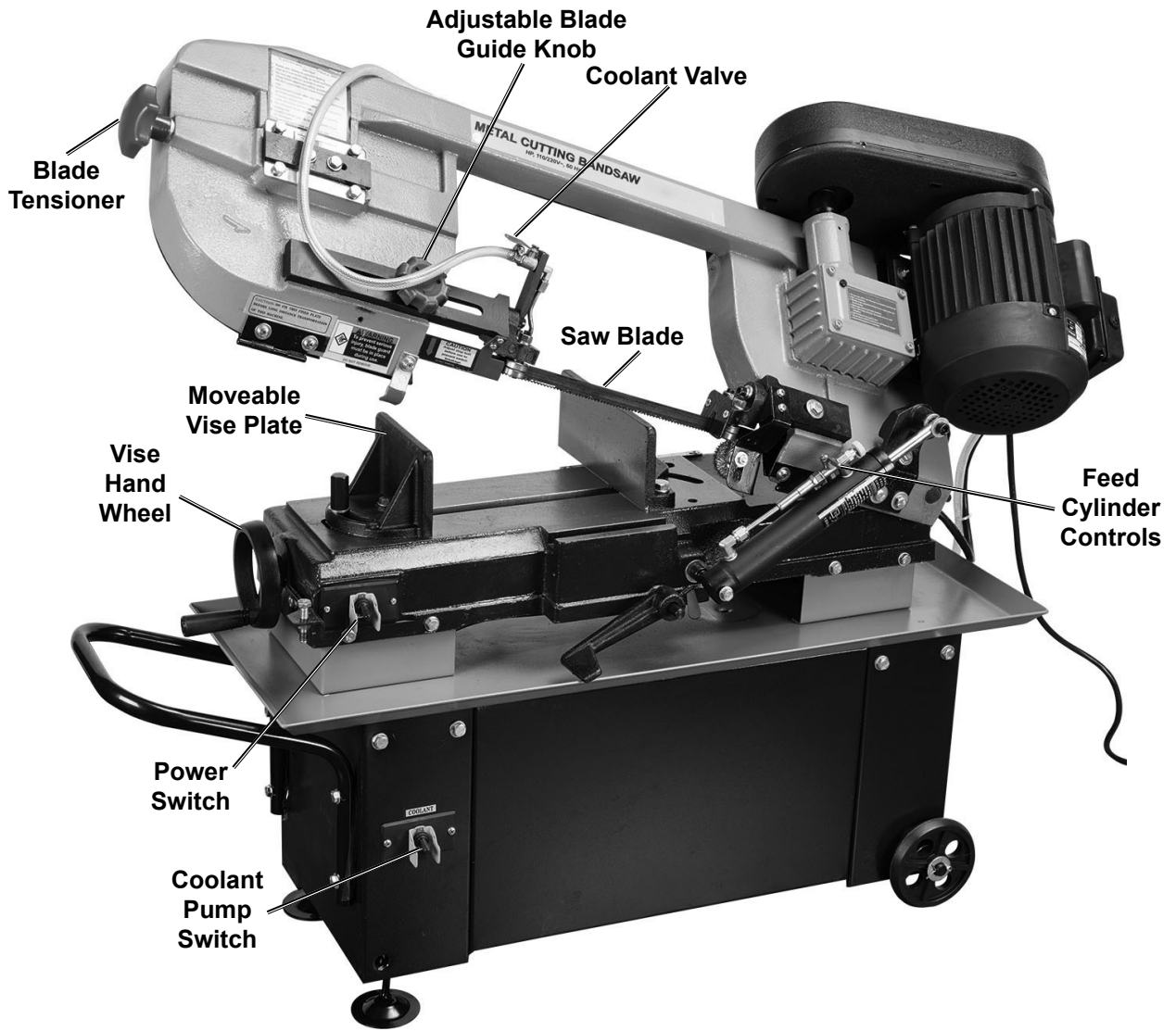

Operating Instructions



Read the **ENTIRE IMPORTANT SAFETY INFORMATION** section at the beginning of this manual including all text under subheadings therein before set up or use of this product.

Tool Set Up

WARNING

TO PREVENT SERIOUS INJURY FROM ACCIDENTAL OPERATION:

Turn the Power Switch of the tool off and unplug the tool from its electrical outlet before performing any procedure in this section.

TO PREVENT SERIOUS INJURY:

DO NOT OPERATE WITH ANY GUARD DISABLED, DAMAGED, OR REMOVED.

Moving guards must move freely and close instantly.

To Install the Saw Blade

CAUTION! To prevent injury from the Saw Blade (251), wear heavy duty work gloves during blade installation and replacement.

1. Turn the Cylinder's Feed Lock on and raise the Saw Head to its full vertical position. Then turn the Cylinder's Feed Lock off to lock the Saw Head in place. (See Figure A.)
2. Open the Blade Back Cover (286S).
3. Release Saw Blade tension by turning the Blade Tension Knob (245).
4. Slip the old Saw Blade off the Idler Wheel (250S), Drive Wheel (231S), and Guide assemblies.
5. Place the new Saw Blade between each of the Guide assemblies and around the Idler Wheel and Drive Wheel. **IMPORTANT: The teeth must be pointing downward toward the Motor.**

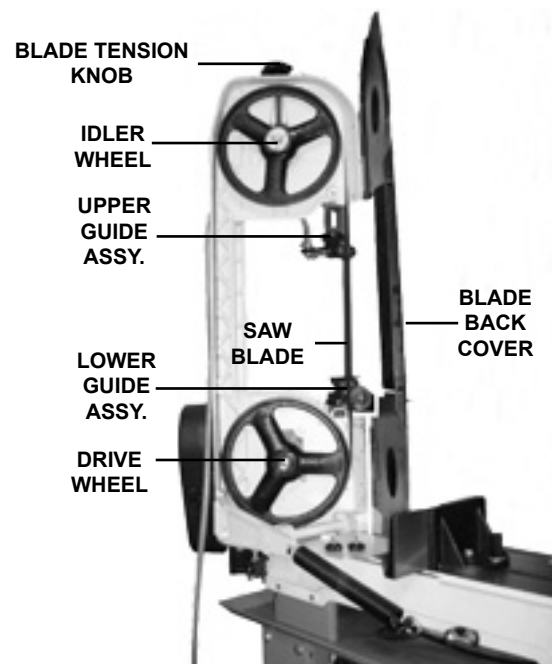

Figure A

NOTE: The Band Saw is equipped with a 93" long, 0.031" thick, 3/4" wide, 6 teeth per inch (TPI) Saw Blade. Depending on material to be cut, thickness of material, preference and wear, replace the blade. Please refer to blade supplier literature, plus woodworker and metal worker magazines and websites for selection.

CAUTION! If the teeth of the Saw Blade are so far apart that they straddle the workpiece, severe damage to the workpiece and/or Saw Blade will result.

6. Tighten the new Saw Blade by turning the Blade Tension Knob in a clockwise direction.
7. Close the Blade Back Cover.

To Adjust The Blade Tension

Turn the Blade Tension Knob (245) clockwise to increase tension on the Saw Blade (251). Turn the Knob counterclockwise to decrease tension on the Saw Blade. Correct tension is acquired when the Saw Blade does not slip on the Drive and Idler wheels (231S and 250S). (See Figure B and Figure A.)

NOTE: When the Bandsaw is not in use over long periods of time, release the tension on the Saw Blade.

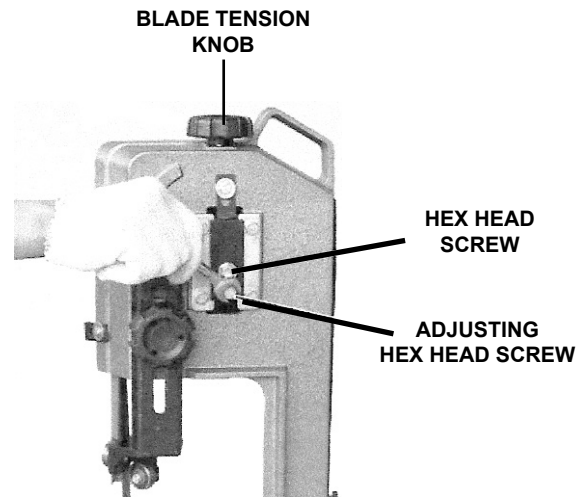

Figure B

To Adjust The Blade Guide Bearings

IMPORTANT: Blade Guide Bearings (266-10) adjustment is a critical factor in the performance of the Bandsaw. Replace the Saw Blade (251) to see if it will correct poor cutting quality before adjusting the Blade Guide Bearings. For example, if a Saw Blade becomes dull on one side sooner than the other, it will begin cutting crooked. Replacing the Saw Blade will correct this problem, but adjusting the Blade Guide Bearings will not.

1. If a new Saw Blade does not correct the problem, check the clearance between the Saw Blade and Blade Guide Bearings to obtain proper clearance. There should only be a maximum of 0.001 clearance between the Saw Blade and Blade Guide Bearing. To obtain this clearance, adjust as follows:
2. The Blade Guide Bearings (266-10) are mounted to the Guide Pivot Assemblies (270S) and can be adjusted. (See Figure C.)
3. Loosen the Hex Socket Head Screw (269-9) while holding the Guide Pivot Assembly with a hex key (not included).
4. Position the Guide Pivot Assembly by turning it to the desired position of clearance. Then re-tighten the Hex Head Socket Screw.
5. Adjust the second Blade Guide Bearing in the same manner.

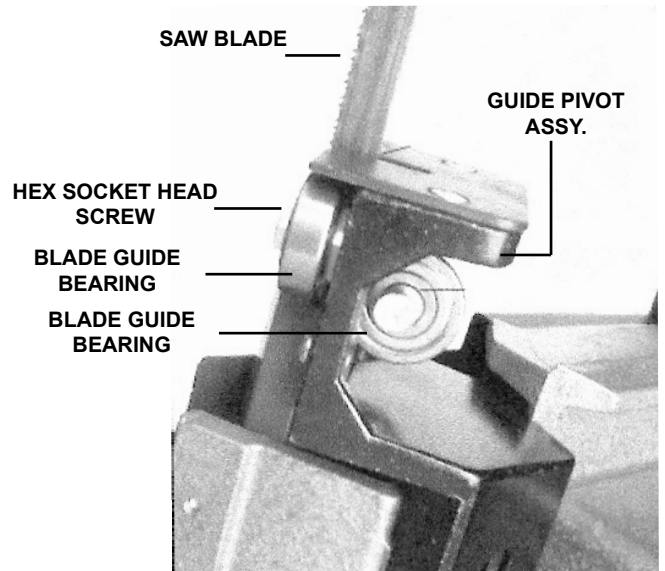

Figure C

To Adjust The Blade Tracking

1. Raise the Bandsaw to its full vertical position, making sure it locks in position by turning the Cylinder's Feed Lock off. (See Figure G.)
2. Turn on the Bandsaw. The Saw Blade (251) is tracking properly when the back of the Blade is just touching the edge of the Idler Wheel (250S) flange. The back of the Blade should not be rubbing against the flange. (See Figure B.)
3. If adjustment is necessary, the Blade Guide Bearings (266-10) should be clear of the Saw Blade. (See Figure C.)
4. Loosen the upper Hex Head Screw (243) to a point where it is just barely snug. (See Figure B.)
5. With the Bandsaw running, turn the Adjusting Hex Head Screw (240) until the Saw Blade is tracking properly, making sure Blade tension is maintained by turning the Blade Tension Knob (245) clockwise.
6. Retighten the upper Hex Head Screw when adjustment is complete.

To Adjust The Blade Speed

Before use, change the Saw Blade (251) speed to suit the material being cut. The chart below shows settings for several materials.

Material	Motor Pulley	Saw Pulley	Speed
Stainless Alloy Steel Bearing Bronze			90 FPM
Medium to High Carbon Steel Hard Brass or Bronze			135 FPM
Low to Medium Carbon Steel Soft Brass			195 FPM
Aluminum Plastic			255 FPM

Figure D

1. To adjust the Saw Blade speed, loosen the two Nuts (304) and Screws (307-2). Slide the Motor (300) forward to release tension on the V-Belt (208). (See Figure E.)
2. Remove the V-Belt from its two Pulleys (206, 296). Place the V-Belt onto the two Pulleys according to the Saw Blade speed desired. (See Figure D.)
3. Then move the Motor back to its original position and secure in place by tightening the previously loosened two Nuts and Screws. (See Figure E.)
4. Verify V-Belt tension by pressing the V-Belt between the pulleys. Deflection should be about 3/8". In time, the V-Belt will stretch and loosen. Loosen the Nut (302) and back off the V-Belt Tension Limiter Bolt (301).
5. Turn the V-Belt Tension Limiter Bolt against the Motor Mount Bracket (307) and tighten the Nut (302).

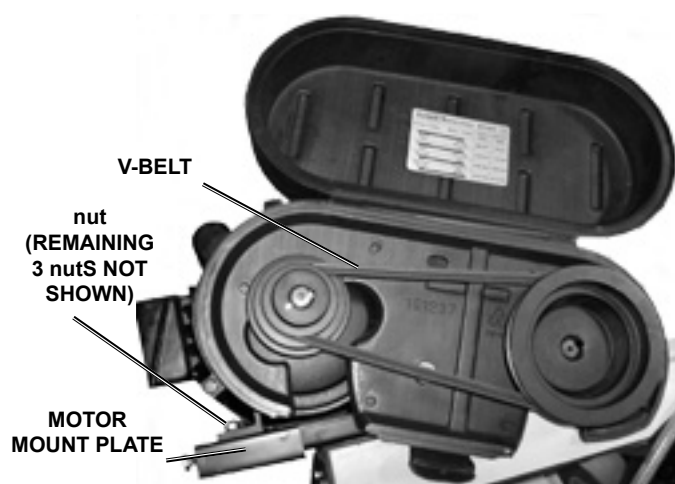

Figure E

To Fill The Coolant Tank

NOTE: When cutting magnesium, use soluble oils or emulsions (oil/water mix) as water only will greatly intensify any accidental magnesium chip fire. Contact industrial coolant supplier for specific coolant recommendations before cutting magnesium.

1. Remove the Hose (78) at the top of the Coolant Tank (82). Then slide the Coolant Tank out from under the Stand (77S) of the Bandsaw. (See Figure F.)
2. Fill the Coolant Tank to about 80% capacity with a clean, water-soluble coolant (not included).
3. Slide the Coolant Tank back under the Stand of the Bandsaw. Then re-insert the Hose through the top of the Coolant Tank.

IMPORTANT: Replace the water-soluble coolant as often as is necessary to keep metal debris in the coolant from clogging the hoses.

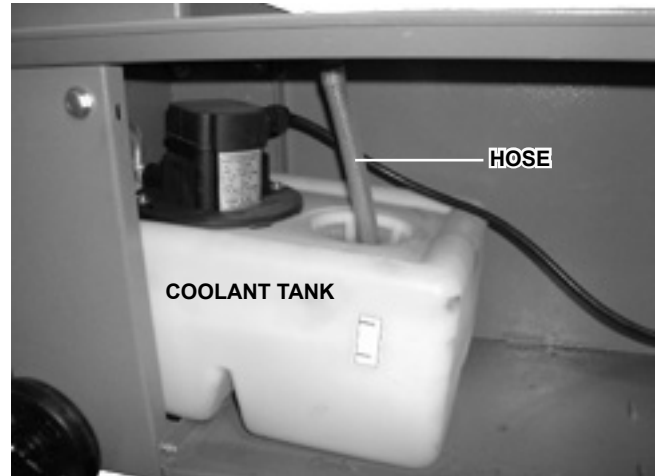

Figure F

To Convert The Bandsaw For Vertical Use

NOTE: Notching, slitting, and contour work is best done with the Bandsaw in its vertical position.

1. Raise the Saw Head to its full vertical position and lock it into position by turning the Cylinder's Feed Lock off (position the lever across the Cylinder). (See Figure G.)



Figure G

2. Remove the two Screws (266-7), and remove the Deflector Plate (266-3). (See Figure H.)

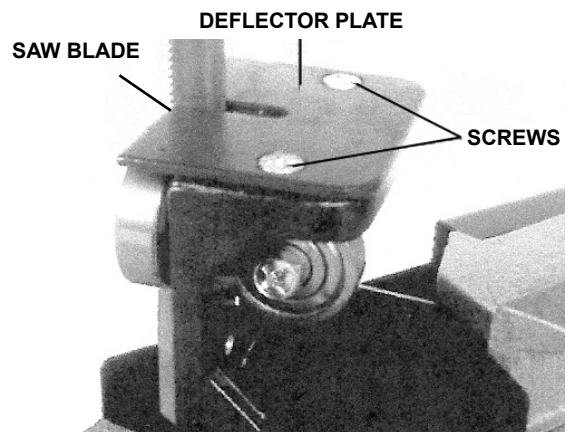

Figure H

3. Guide the Saw Blade (251) through the slot in the Vertical Table (55-2), and secure it in position with the two Screws. (See Figure I.)

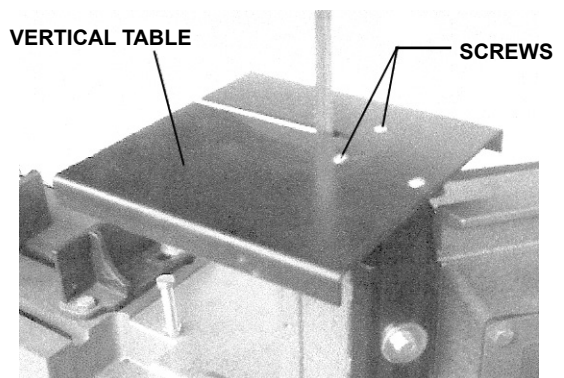

Figure I

To Adjust The Feed Rate

Feed rate is adjusted by the Feed Knob above Feed Lock of the Cylinder (see Figure J).

1. Turn the Feed Knob on the Cylinder clockwise to decrease the feed rate.
2. Turn the Feed Knob on the Cylinder counterclockwise to increase the feed rate.

NOTICE: Do not turn the Feed Knob more than one turn at a time. Excessive feed pressure can break the Saw Blade. Insufficient feed pressure dulls the Saw Blade rapidly.

3. The Feed Lock locks or unlocks Cylinder movement entirely.

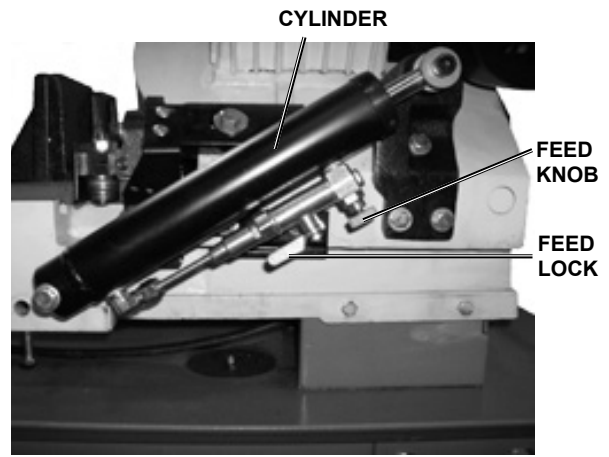

Figure J

Workpiece and Work Area Set Up

1. Designate a work area that is clean and well-lit. The work area must not allow access by children or pets to prevent distraction and injury.
2. Route the power cord along a safe route to reach the work area without creating a tripping hazard or exposing the power cord to possible damage. The power cord must reach the work area with enough extra length to allow free movement while working.
3. Secure loose workpieces using a vise or clamps (not included) to prevent movement while working.
4. There must not be objects, such as utility lines, nearby that will present a hazard while working.

To Use The Quick Vise

1. Place the workpiece between the Vise Jaws (9, 22) with the amount to be cut off extending out past the Saw Blade (251). (See Figure K.)
2. The Bandsaw is equipped with a quick action Vise Jaw mechanism which allows you to instantly position the moveable Front Vise Jaw (9).
3. To operate, turn the Hand Wheel (5S) counterclockwise 1/2 turn and move the Front Vise Jaw to the desired position. Then tighten the Front Vise Jaw against the workpiece by turning the Hand Wheel clockwise.

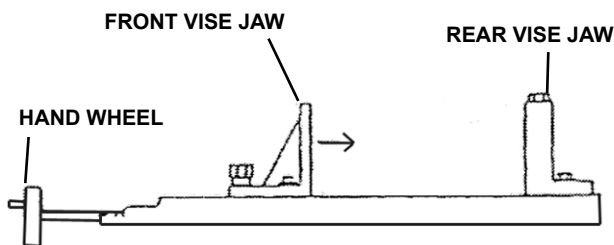
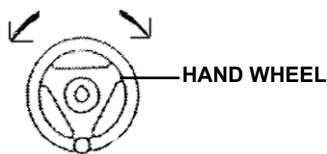
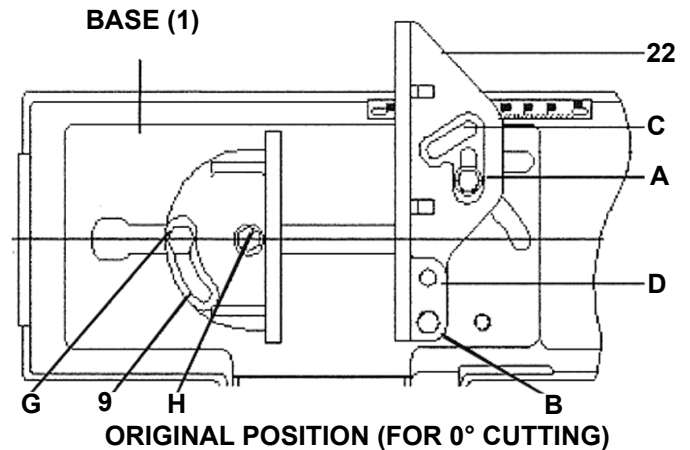
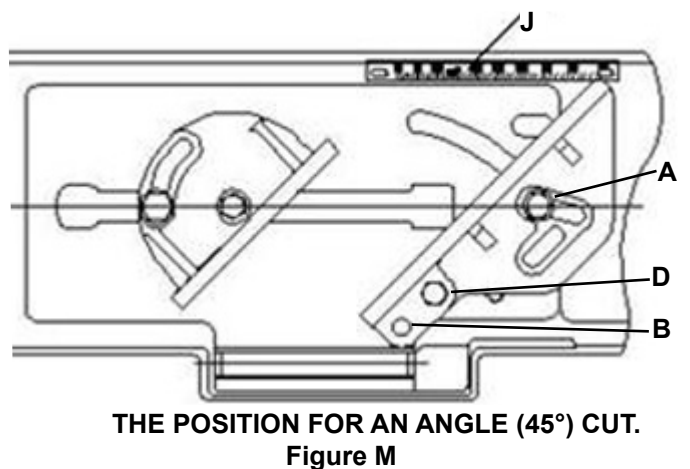

Figure K

4. Setting up the Quick Vise for a straight (0°) cut:
 - Loosen the Screws (H) and (G) of Front Vise Jaw (F).
 - Turn the Hand Wheel counterclockwise by half a turn and slide back the Front Vise Jaw.
 - Loosen Screw (A and B) and note that Screw (A) should be in the slot which is parallel with the Rear Vise Jaw.
 - Rear Vise Jaw at the scale side should be aligned with the zero (0) on the rule. Tighten Screws (A and B). (See Figure L.)
 - Free "C" slot of casting flush so the vise can be positioned in all angles.



5. Setting up the Quick Vise an angle:
 - Remove Screws (A and B) from base of the Rear Vise Jaw.
 - Position (D) over (B) and attach the Screw and Washer (19 and 22) and attach Screw (B).
 - Attach Carriage Screw (17) onto Slot (C) through the curved slot in the Base (1).
 - Align edge of the Rear Vise Jaw with the indexing rule and tighten Screws at (B and C). (See Figure M.)



6. Setting up the Quick Vise for cutting a 12" workpiece:
 - Remove both fasteners from the Rear Vise Jaw.
 - Position (B) over the outer threaded hole on the Base.
 - Position Slot (A) over the small rectangular opening across the Base.
 - Attach Screws (A and B). Align the lower edge of the Rear Vise Jaw with the "0" index mark adjacent to the 16° degree setting. Tighten the screws. (See Figure N)

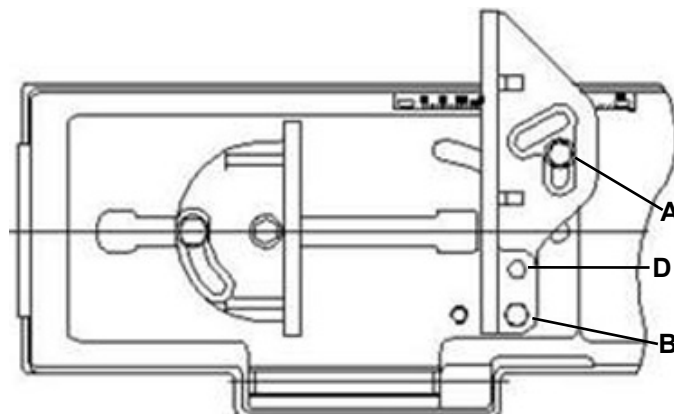

Figure N

To Adjust The Stop Block

For repeated cuts of pre-set lengths:

1. Loosen the Thumb Screw (38) that holds the Stop Block (41) to the Stock Stop Rod (40). (See Figure O)
2. Adjust the Stop Block to the desired length position. Then re-tighten the Thumb Screw.

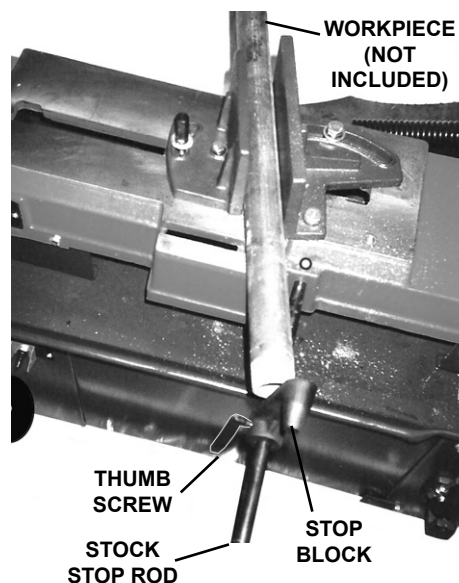

Figure O

To Adjust The Blade Guide Brackets

1. The Blade Guide Knob (261) is adjusted by loosening the Knob and sliding the Blade Guide Bracket (269S) up or down to accommodate the width of the workpiece. (See Figure P.)
2. The Blade Guide Bracket should be set as close as possible to the workpiece, without interfering with the workpiece.
3. Retighten the Blade Guide Knob.



Figure P

General Operating Instructions

Vertical Operation

⚠️ WARNING

Always wear ANSI-approved safety impact eye goggles when operating the Bandsaw. Never wear loose fitting clothing.

When operating the machine, keep the Bandsaw Blade enclosure closed.

Do not plug the Power Cord into an electrical outlet until all necessary adjustments (as previously discussed in this manual) have been made.

Cut only flat workpieces when the Bandsaw is in its vertical position. Never attempt to cut pipes or other round objects with the Bandsaw in its vertical position.

Before cutting, turn on the Bandsaw and check for loose Saw Blade or machine vibration. If this is found, turn off the Bandsaw and correct the problem before using.

Always keep hands and fingers safely away from the cutting area.

1. Raise the Saw Head to its full vertical position, making sure it locks in place by turning the Cylinder's Feed Lock off.
2. Check to make sure the Motor Switch and Coolant Pump Switch are both in their "OFF" positions.
3. Plug the Power Cord into the nearest 120 volt, grounded, electrical outlet (or 240 volt outlet, depending on how the Bandsaw is wired).
4. Open the Coolant Valve, then turn the Coolant Pump Switch on.
5. Turn the Motor Switch on.
6. Set the workpiece on the Vertical Table making sure to keep downward pressure on the workpiece throughout the cutting process.
7. When cutting a large workpiece properly support its entire length. If necessary, use a roller stand (not included) with a large workpiece.
8. Allow the Saw Blade to turn up to full speed before feeding the workpiece into the Blade.
9. Feed the workpiece into the Saw Blade gradually. Do not force the Bandsaw to remove material faster than it is designed to cut.
10. Use two hands and hold workpiece securely against table at all times.

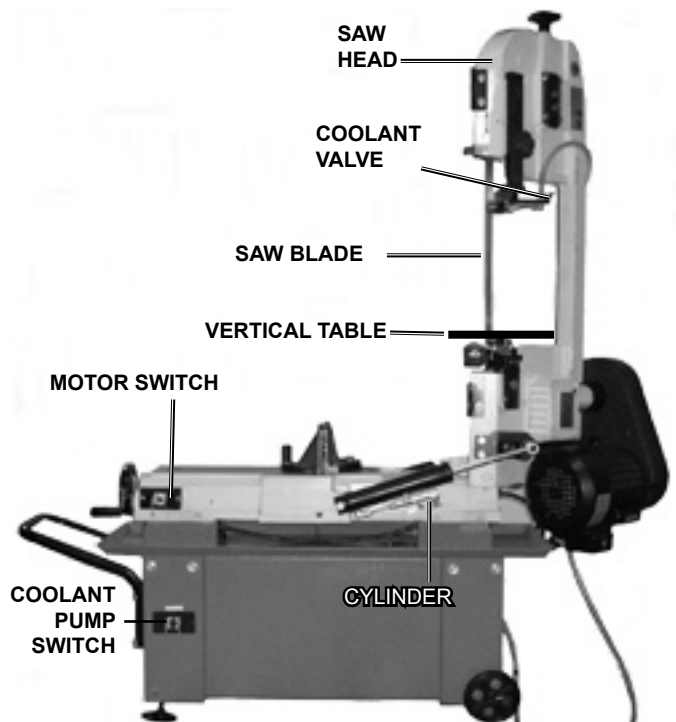

Figure Q

WARNING! TO PREVENT SERIOUS INJURY:

Do not remove material stuck near the moving parts of the Bandsaw while it is plugged in and running. Turn off the Bandsaw if the workpiece is to be backed out of an uncompleted cut.

11. Once the cut is made, turn Motor and Coolant Pump Switches off and close the Coolant Valve. Then unplug the Power Cord from its electrical outlet.
12. Wait until the Saw Blade comes to a complete stop. Then remove the workpiece and scrap material from the Vertical Table.
13. Turn the Cylinder's Feed Lock on. Slowly lower the Saw Head to its horizontal position. Then turn the Cylinder's Feed Lock off to lock the Saw Head in place.

Horizontal Operation

⚠ WARNING

Always wear ANSI-approved safety impact eye goggles when operating the Bandsaw. Never wear loose fitting clothing.

When operating the machine, keep the Bandsaw Blade enclosure closed.

Do not plug the Power Cord into an electrical outlet until all necessary adjustments (as previously discussed in this manual) have been made.

Before cutting, turn on the Bandsaw and check for loose Saw Blade or machine vibration. If this is found, turn off the Bandsaw and correct the problem before using.

Always keep hands and fingers safely away from the cutting area.

1. Turn the Cylinder's Feed Lock on, and raise the Saw Head to its full vertical position. Then turn the Cylinder's Feed Lock off to lock the Saw Head in place.
2. Secure the workpiece in the Vise assembly. When cutting a large workpiece, make sure its entire length is properly supported. If necessary, use a roller stand (not included) with a large workpiece.
3. If cutting several workpieces at the same length, you may wish to adjust the Stop Block to the desired position.
4. Check to make sure the Motor Switch and Coolant Pump Switch are both in their "OFF" positions.
5. Plug the Power Cord into the nearest 115 volt, grounded, electrical outlet (or 230 volt outlet, depending on how the Bandsaw is wired).
6. Open the Coolant Valve, then turn the Coolant Pump Switch on.
7. Turn the Motor Switch on.
8. Turn the Cylinder's Feed Lock on and slowly lower the Saw Head until the Saw Blade is just above the workpiece cut line.
9. Allow the Saw Blade to turn up to full speed before feeding the Blade into the workpiece.
10. Use the clamp to hold the workpiece securely.
11. Through the Hydraulic Feed System, allow the Saw Arm to lower, while it gradually feeds the Saw Blade into the workpiece. Do not force the Bandsaw to remove material faster than it was designed to cut.

NOTE: The speed at which the Saw Arm moves downward may be increased or decreased by adjusting the Feed Knob on the Cylinder.

WARNING! TO PREVENT SERIOUS INJURY:

Do not remove material stuck near the moving parts of the Bandsaw while it is plugged in and running. Turn off the Bandsaw if the workpiece is to be backed out of an uncompleted cut.

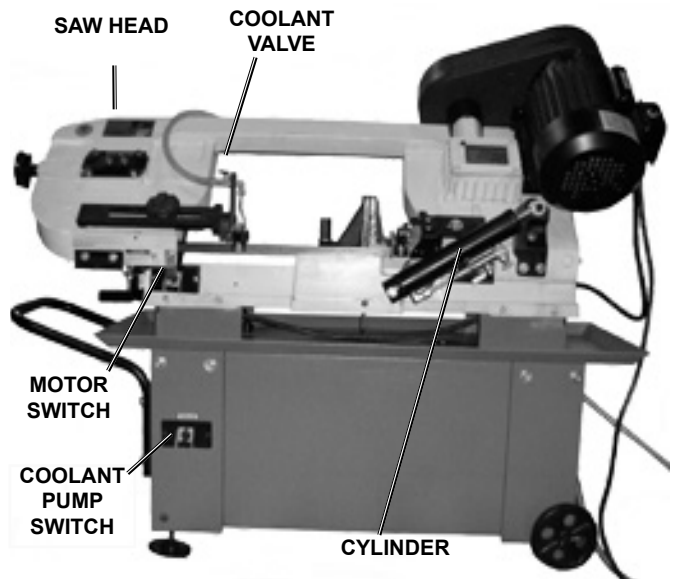

Figure R

12. IMPORTANT: When in the horizontal cutting mode only, the Motor Switch will automatically turn to its "OFF" position and shut off the Bandsaw's Motor when the cut has been completed.
13. Once the cut is made, and the motor is switched off, turn the Coolant Pump Switch off and close the Coolant Valve. Then unplug the Power Cord from its electrical outlet.
14. Wait until the Saw Blade comes to a complete stop. Then raise the Saw Head to its full vertical position. Turn the Cylinder's Feed Lock off to lock the Saw Head in place. Remove the workpiece from the Vise assembly and scrap material from the Base of the Bandsaw.
15. Turn the Cylinder's Feed Lock on. Slowly lower the Saw Head to its horizontal position. Then turn the Cylinder's Feed Lock off to lock the Saw Head in place.

Maintenance and Servicing



Procedures not specifically explained in this manual must be performed only by a qualified technician.

⚠️ WARNING

TO PREVENT SERIOUS INJURY FROM ACCIDENTAL OPERATION:

Turn the Power Switch of the tool off and unplug the tool from its electrical outlet before performing any procedure in this section.

TO PREVENT SERIOUS INJURY FROM TOOL FAILURE:

Do not use damaged equipment. If abnormal noise or vibration occurs, have the problem corrected before further use.

Cleaning, Maintenance, and Lubrication

1. **BEFORE EACH USE**, inspect the general condition of the tool. Check for:

- loose hardware,
- misalignment or binding of moving parts,
- cracked or broken parts,
- damaged electrical wiring, and
- any other condition that may affect its safe operation.

2. Periodically, wear ANSI-approved safety goggles and NIOSH-approved breathing protection and blow dust out of the motor vents using dry compressed air.

3. **BEFORE EACH USE**, inspect the Saw Blade (251). Using a dull Saw Blade will cause excessive wear on the Motor of the Bandsaw and will not produce a satisfactory cut. Replace with a new Saw Blade when needed.

4. **AFTER USE**, wipe external surfaces of the tool with clean cloth. **To clean the exterior parts of the Band Saw**, use only a clean cloth and mild detergent or mild solvent to clean the body of the Saw. **Do not immerse any electrical part of the machine in any liquids.**

⚠️ WARNING! All maintenance, service, or repairs not mentioned in this manual must only be performed by a qualified service technician.

⚠️ WARNING! **TO PREVENT SERIOUS INJURY:** If the supply cord of this power tool is damaged, it must be replaced only by a qualified service technician.

To lubricate the Worm Gear Shaft Assembly

The Worm Gear Shaft Assembly (202S) runs in an oil bath Gearbox Assembly (201S) and should not require an oil change more than once a year, unless the oil becomes contaminated or a leak occurs due to improper replacement of the Gearbox Cover. To change oil in the Gearbox Assembly:

1. Position the Saw Arm in the horizontal position.
2. Remove the four Hex Socket Head Screws, Gearbox Cover, and Gearbox Gasket. (See Figure S.)
3. Remove the old oil from inside the Gearbox Assembly and replace the oil using 140 weight gear oil (not included). The new oil should just come to the edge of the Gearbox (202-1). Do not overfill.
4. Remove the Gearbox Gasket, Gearbox Cover, and four Hex Socket Head Screws. (See Figure S and Figure T.)

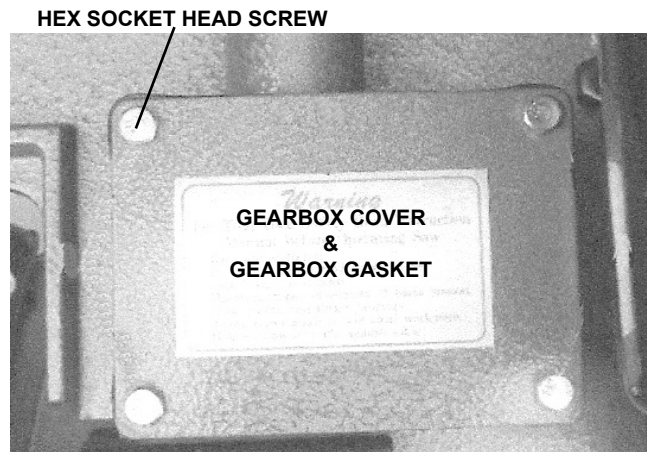

Figure S

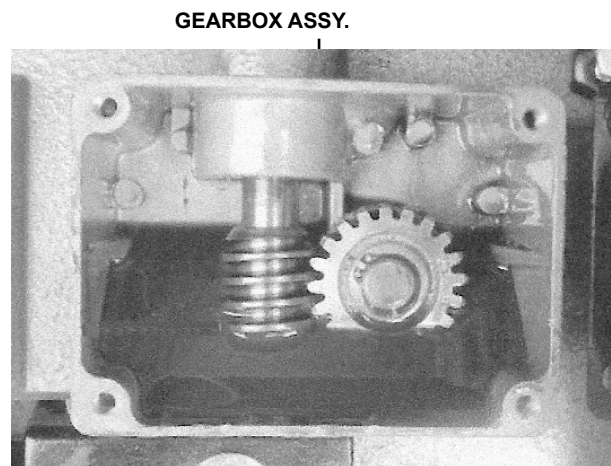

Figure T

To Replace The Coolant

1. Remove the Hose (78) at the top of the Coolant Tank (82). Then slide the Coolant Tank out from under the Stand (77S) of the Bandsaw. (See Figure U.)
2. Fill the Coolant Tank to about 80% capacity with a clean, water-soluble coolant (not included).
3. Slide the Coolant Tank back under the Stand of the Bandsaw. Then re-insert the Hose through the top of the Coolant Tank.
4. **IMPORTANT:** Replace the water-soluble coolant as often as is necessary to keep metal debris in the coolant from clogging the hoses.

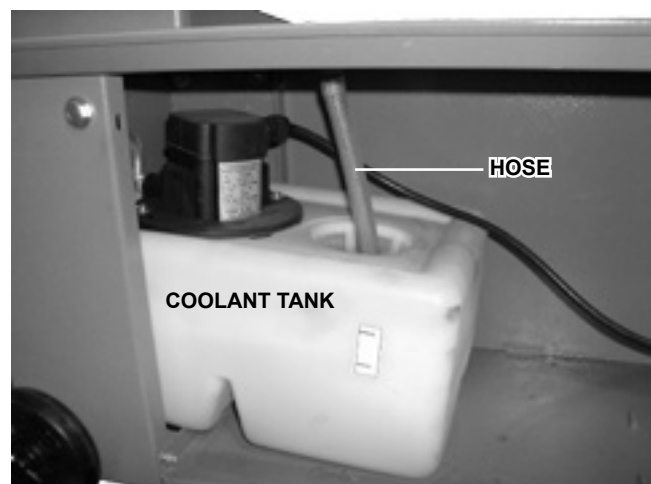

Figure U

Troubleshooting

SAFETY

SETUP

OPERATION

MAINTENANCE

Problem	Possible Causes	Likely Solutions
Tool will not start.	<ol style="list-style-type: none"> 1. Cord not connected. 2. No power at outlet. 3. Tool's thermal reset breaker tripped (if equipped). 4. Internal damage or wear. (Carbon brushes or switch, for example.) 	<ol style="list-style-type: none"> 1. Check that cord is plugged in. 2. Check power at outlet. If outlet is unpowered, turn off tool and check circuit breaker. If breaker is tripped, make sure circuit is right capacity for tool and circuit has no other loads. 3. Turn off tool and allow to cool. Press reset button on tool. 4. Have technician service tool.
Tool operates slowly.	Extension cord too long or wire size too small.	Eliminate use of extension cord. If an extension cord is needed, use one with the proper diameter for its length and load. Table A on page 3.
Performance decreases over time.	<ol style="list-style-type: none"> 1. Saw Blade dull or damaged. 2. Carbon brushes worn or damaged. 	<ol style="list-style-type: none"> 1. Replace Saw Blade. See page 9. 2. Have qualified technician replace brushes.
Excessive noise or rattling.	Internal damage or wear. (Carbon brushes or bearings, for example.)	Have technician service tool.
Overheating.	<ol style="list-style-type: none"> 1. Forcing machine to work too fast. 2. Saw Blade dull or damaged. 3. Blocked motor housing vents. 4. Motor being strained by long or small diameter extension cord. 5. Saw Blade tension is too high. 6. V-Belt tension too high. 7. Blade is too coarse or too fine for workpiece. 8. Gear not aligned properly. 9. Gears need lubrication. 	<ol style="list-style-type: none"> 1. Allow machine to work at its own rate. 2. Replace Saw Blade. See page 9. 3. Wear ANSI-approved safety goggles and NIOSH-approved dust mask/respirator while blowing dust out of motor using compressed air. 4. Eliminate use of extension cord. If an extension cord is needed, use one with the proper diameter for its length and load. See Table A on page 3. 5. Gradually adjust Saw Blade tension until optimal tension has been achieved. See page 13. 6. Gradually adjust V-Belt tension until optimal tension has been achieved. See page 11. 7. See <i>To Install the Saw Blade on page 9</i> for recommended Blade type. Replace with more appropriate Saw Blade. 8. Adjust Gears so that Worm is in center of Gear. 9. Check oil bath. See page 19.
Excessive Blade breakage.	<ol style="list-style-type: none"> 1. Saw Blade is loose. 2. Saw Blade turns too quickly or too slowly. 3. Vise is not gripping the workpiece. 4. Wheel Flange is eroding Saw Blade. 5. Saw Blade teeth are spaced too widely for the workpiece material. 6. Saw Blade is not permitted to reach full speed before workpiece is fed into it. 7. Blade Guides are poorly aligned. 	<ol style="list-style-type: none"> 1. Tighten Blade tension. 2. Check manual for correct Blade speed. See page 11. 3. Clamp workpiece securely. 4. Adjust Saw Blade tracking. See page 10. 5. See <i>To Install the Saw Blade on page 9</i> for recommended Blade type. Replace with more appropriate Saw Blade. 6. Allow Blade to reach full speed before feeding material into it. 7. Adjust Blade Guides.



Follow all safety precautions whenever diagnosing or servicing the tool. Disconnect power supply before service.

Problem	Possible Causes	Likely Solutions
Premature Blade dulling	<ol style="list-style-type: none"> 1. Saw Blade teeth are spaced too widely for the workpiece material. 2. Saw Blade turns too quickly. 3. Body Frame descends too lightly. 4. Saw Blade installed backwards. 5. Insufficient Saw Blade tension. 	<ol style="list-style-type: none"> 1. For recommended Blade type, see To Adjust The Blade Speed on page 11 and replace with appropriate Saw Blade. 2. Try next lower speed. See page 11. 3. Increase tension according to To Adjust The Feed Rate on page 13. 4. Re-install Saw Blade properly. 5. Gradually increase Saw Blade tension until optimal tension has been achieved. See page 13.
Blade cuts crooked.	<ol style="list-style-type: none"> 1. Vise is not square with Saw Blade. 2. Feed pressure is too great. 3. Guide Bearing is not adjusted properly. 4. Insufficient Saw Blade tension. 5. Blade Guides are too far from workpiece. 6. Saw Blade is dull. 7. Saw Blade turns too quickly or too slowly for workpiece. 8. Saw Blade tracks too far away from Wheel Flanges. 	<ol style="list-style-type: none"> 1. Adjust Vise so it is square with Blade. Always clamp work tightly in Vise. 2. Reduce tension according to To Adjust The Feed Rate on page 13. 3. Adjust Guide Bearing to 0.001" greater than maximum thickness, including the weld of the Saw. See page 10. 4. Gradually increase Saw Blade tension until optimal tension has been achieved. See page 13. 5. Move Blade Guide as close to workpiece as possible. 6. Replace Saw Blade. See page 9. 7. Check Manual for recommended speeds. See page 11. 8. Adjust Saw Blade tracking. See page 10.
Blade cuts rough.	<ol style="list-style-type: none"> 1. Saw Blade turns too quickly. 2. Feed pressure is too heavy. 3. Saw Blade teeth are spaced too widely for the workpiece material. 	<ol style="list-style-type: none"> 1. See page 11 for recommended speeds. 2. Reduce tension according to To Adjust The Feed Rate on page 13. 3. Check manual for recommended Blade type. See page 9 and replace with more appropriate Saw Blade.
Blade twists.	<ol style="list-style-type: none"> 1. Saw Blade is caught in the workpiece cut. 2. Saw Blade tension is too high. 	<ol style="list-style-type: none"> 1. Reduce tension according to To Adjust The Feed Rate on page 13. 2. Gradually adjust Saw Blade tension until optimal tension has been achieved. See page 13.
Unusual wear on side/back of Blade.	<ol style="list-style-type: none"> 1. Blade Guides are worn down. 2. Blade Guide Bearings are out of place. 3. Blade Guide Bearing Bracket is loose. 	<ol style="list-style-type: none"> 1. Replace Blade Guides. See page 14. 2. Adjust Blade Guide Bearings. See 3. Tighten Blade Guide Bearing Bracket



**Follow all safety precautions whenever diagnosing or servicing the tool.
Disconnect power supply before service.**

PLEASE READ THE FOLLOWING CAREFULLY

THE MANUFACTURER AND/OR DISTRIBUTOR HAS PROVIDED THE PARTS LIST AND ASSEMBLY DIAGRAM IN THIS MANUAL AS A REFERENCE TOOL ONLY. NEITHER THE MANUFACTURER OR DISTRIBUTOR MAKES ANY REPRESENTATION OR WARRANTY OF ANY KIND TO THE BUYER THAT HE OR SHE IS QUALIFIED TO MAKE ANY REPAIRS TO THE PRODUCT, OR THAT HE OR SHE IS QUALIFIED TO REPLACE ANY PARTS OF THE PRODUCT. IN FACT, THE MANUFACTURER AND/OR DISTRIBUTOR EXPRESSLY STATES THAT ALL REPAIRS AND PARTS REPLACEMENTS SHOULD BE UNDERTAKEN BY CERTIFIED AND LICENSED TECHNICIANS, AND NOT BY THE BUYER. THE BUYER ASSUMES ALL RISK AND LIABILITY ARISING OUT OF HIS OR HER REPAIRS TO THE ORIGINAL PRODUCT OR REPLACEMENT PARTS THERETO, OR ARISING OUT OF HIS OR HER INSTALLATION OF REPLACEMENT PARTS THERETO.

Parts List and Diagram

Parts List

SAFETY

SETUP

OPERATION

MAINTENANCE

Part	Description	Qty
1	Cover	1
2	Acme Screw	1
3	1/2"x28xt2 Washer	1
4	5x5x15L Key	1
5S	Wheel	1
7	Fixed Bolt	1
8	3/8"x25xt2 Washer	2
9	Vise Jaw Bracket (Front)	1
10	Ø5x35L Pin	1
11	Bracket	1
12S	Acme Nut Assembly	1
13	Scale	1
14	3/16"x12xt0.8 Washer	2
15	3/16"x3/8"L Cross Round Head Screw	2
16	5/8" Wire Connector	1
17	1/2"x2"L Carriage Screw	1
18	1/2" Nut	1
19	1/2"x28xt2 Washer	2
20	3/8"x1-1/2"L Hex. Head Screw	1
21	1/2"x2"L Hex. Head Screw	1
22	Vise Jaw Bracket (Rear)	1
23	Bushing	1
24	Support Rod	1
25	5/16"x3/4"L Screw	1
26	Pivot Bracket	1
27	Washer	1
28	3/8"x1-1/2"L Hex. Head Screw	2
29	Support Plate	1
30	Fixed Plate	1
31	Spring	1
32	Spring Adjusting Rod	1
33	Spring Handle Bracket	1
34	5/16"x3/4"L Hex. Head Screw	1
35	5/16"x23xt2 Washer	1
35-1	5/16" Nut	1
36	3/8" Nut	1
37	3/8"x23xt2 Washer	1
38	Thumb Screw	1
39	5/16"x3/4"L Hex. Head Screw	1
40	Stock Stop Rod	1
41	Stop Block	1
42	5/16"x1-1/2"L Hex. Head Screw	1
42-1	1/4"x19xt1.5 Washer	1
45	Support Plate	1
46	3/8"x1-3/4"L Hex. Head Screw	1
47	3/8" Nut	1
48	5/16"x3/4"L Hex. Head Screw	2
49	5/16"x18xt1.5 Washer	2
50	3/8"x1-3/4"L Hex. Head Screw	1
51	3/8" Nut	1
52	5/16"x3/4"L Hex. Head Screw	2
53	5/16"x18xt1.5 Washer	2
55-1	1/4"x3/8"L Flat Cross Head Screw	1
55-2	Vertical Table	1
55-4	1/4" Nut	1
56	Warning Label	1
65	Filter	1
66	Switch Cut Off Tip	1
68	3/8"x18xt1.5 Washer	8
69	5/16" Nut	9
72	5/16"x1"L Hex. Head Screw	7
73	5/16"x1-1/4"L Hex. Head Screw	1

Part	Description	Qty
75	3/16"x3/8"L Cross Round Head Screw	2
77S	Stand Assembly	1
78	1/2" Hose	1
82	Coolant Tank	1
84S	Pump	1
85	1/4"x5/8"L Cross Round Head Screw	2
86	1/4"x19xt1.5 Washer	2
88	3/8"PTx5/16" Coupler	1
89	5/8" Hose Clip	2
90	5/16"x2000 Hose	1
91S	Fitting	1
92-1	3/8" Washer	2
92-2	Wheel	2
92-3	Ø3x25L Cotter Pin	2
92-4	Wheel Rod	1
93	Coaster of Stand	2
98-1	Hand Rod	1
98-2	5/16"x1-1/2"L Hex. Head Screw	4
98-3	5/16"x18xt1.5 Washer	8
98-4	5/16" Nut	4
130	Bracket	1
130	Bracket	1
131	M4x5L Cross Round Head Screw	4
132	Switch Base	1
132	Switch base	1
133	M5 Washer	2
134	M4x10L Cross Round Head Screw	2
135	5/16"x23xt3 Washer	1
136	5/16"x3/4"L Hex. Head Screw	1
139	Washer	1
140	Cylinder Lower Support	1
141	5/16"x19xt1.5 Washer	1
142	5/16"x1/2"L Hex. Head Screw	1
201S	Gearbox Assembly	1
202S	Worm Gear Shaft Assembly	1
203	5x5x30L Key	1
206	Spindle Pulley	1
207	1/4"x3/8"L Hex. Socket Headless Screw	2
208	3Vx270 V-Belt	1
209	Cover	1
210	3/8" Nut	1
211	3/8"x20xt2 Washer	1
212	Cylinder Upper Support	1
213	5/16"x18xt1.5 Washer	3
214	5/16"x1"L Hex. Head Screw	3
215	3/8"x23xt2 Washer	2
216	RF-712N Cylinder Complete Set	1
217	3/8"x2-1/4"L Hex. Socket Head Screw	1
218	Body Frame	1
219	3/8"Spring Washer	4
220	3/8"x1-1/4"L Hex. Head Screw	4
230	S25C - Retaining Ring	1
231S	Drive Wheel	1
232	6x6x20L Key	1
233	5/16"x3/4"L Hex. Head Screw	1
234	1/4"x5/8"L Cross Socket Hex. Head Screw	2
235	1/4"x16xt1.5 Washer	2
236	Support Plate	1
237	Sliding Plate	2
238	Blade Tension Sliding Block	1
239	5/16"x3/4"L Hex. Socket Headless Screw	1
240	5/16"x1-1/2"L Hex. Head Screw	2

Part	Description	Qty
241	5/16"x12xt2 Washer	2
242	5/16" Spring Washer	4
243	5/16"x3/4"L Hex. Head Screw	4
244	Spring	1
245	Blade Tension Knob	1
246	3/8"x25xt2 Washer	1
249S	Shaft Assembly	1
250S	Idler Wheel Assembly	1
251	0.032"x3/4"x93"x6-10T Blade	1
252	Switch Cut Off Tip	1
253	1/4"x16xt1.5 Washer	1
254	1/4"x5/8"L Cross Socket Hex. Head Screw	1
255	3/8"x1-1/4"L Hex. Head Screw	1
256	3/8"x25xt2 Washer	1
258S	Brush Assembly	1
259	3/16"x3/8"L Cross Round Head Screw	2
261	Blade Guide Knob	1
262	3/8"x25xt2 Washer	1
266S	Blade Guide Bracket (Rear)	1
267S	Guide Pivot Assembly	1
268S	Bearing Shaft Assembly	1
269S	Blade Guide Bracket (Front)	1
270S	Guide Pivot Assembly	1
271S	Bearing Shaft Assembly	1
279	Blade Cover (Front)	1
280	5/32"x1/4"L Cross Round Head Screw	2
284	Plum handle	2
285	1/4"x16xt1.5 Washer	2
286S	Blade Back Cover	1
288	1/4"x16xt1.5 Washer	4
289	1/4"x1/2"L Cross Round Head Screw	4
290	1/4"x1/2"L Cross Socket Hex. Head Screw	1
290	Plum handle	1
291	Motor Pulley Cover	1
293	1/4"x5/8"L Cross Socket Hex. Head Screw	2
294	1/4"x19xt1.5 Washer	2
295	5x5x30L Key	1
296	Motor Pulley	1
297	1/4"x3/8"L Hex. Socket Headless Screw	1
298	5/16"x3/4"L Carriage Screw	4
300	Motor	1
301	5/16"x1"L Hex Head Screw	2
302	5/16" Nut	2
303	Motor Mount Plate	1
304	5/16" Nut	4
305	5/16"x3/4"L Hex. Head Screw	4

Part	Description	Qty
306	5/16"x23xt2 Washer	12
307	Motor Mount Bracket	1
307-1	5/16"X23Xt2 Washer	2
307-2	5/16"X7/8"L Hex. Head Screw	2
343	1/4"x16xt1.5 Washer	1
345	Emergency Switch Bracket	1
348	M6x12L Cross Round Head Screw	4
351	3/16"x3/8"L Hex. Socket Head Screw	2
600	Knob	1
601	Knob	1
602	1/4"x1/2"L Hex. Socket Headless Screw	1
603	Pressure Lump	1
604	Ø12xt2 Washer	1
605	3/8"x1-1/4"L Hex. Head Screw	2
606	3/8"x20xt2 Washer	2
608	Pressure Shaft	1
609	Knob w/Shaft	1
610	RF31\Round Knob	1
611	Bearing	1
612	Ø12xt2 Washer	1
613	Spring	1
614	Acme Screw	1
615	Acme Nut	1
616	1/2"x28xt2 Washer	1
750	Switch Assembly	1
750-1	Switch Cover	1
750-2	Switch Cover	1
750-3	1 Switch Assembly	1
750-3	3 Switch	1
750-4	3/16"x3/8"L Screw	2
750-5	Cover	1
750-6	Rubber Plate	1
750-7	Electrical Box	1
750-8	5/32"x1/8"L Screw	2
750-9	5/8" Wire Connector	2
750-10	1/2" Wire Connector	2
751	Switch Assembly	1
751-1	Switch Cover	1
751-2	Switch Cover	1
751-3	3/16"x3/8"L Screw	2
751-4	Cover	1
751-5	Switch Assembly	1
751-6	Electrical Box	1
751-7	5/32"x1/8"L Screw	2
751-8	1/2" Wire Connector	1

Record Product's Serial Number Here: _____

Note: If product has no serial number, record month and year of purchase instead.

Note: Some parts are listed and shown for illustration purposes only, and are not available individually as replacement parts. Specify UPC 193175560599 when ordering parts.

Assembly Diagrams

SAFETY

SETUP

OPERATION

MAINTENANCE

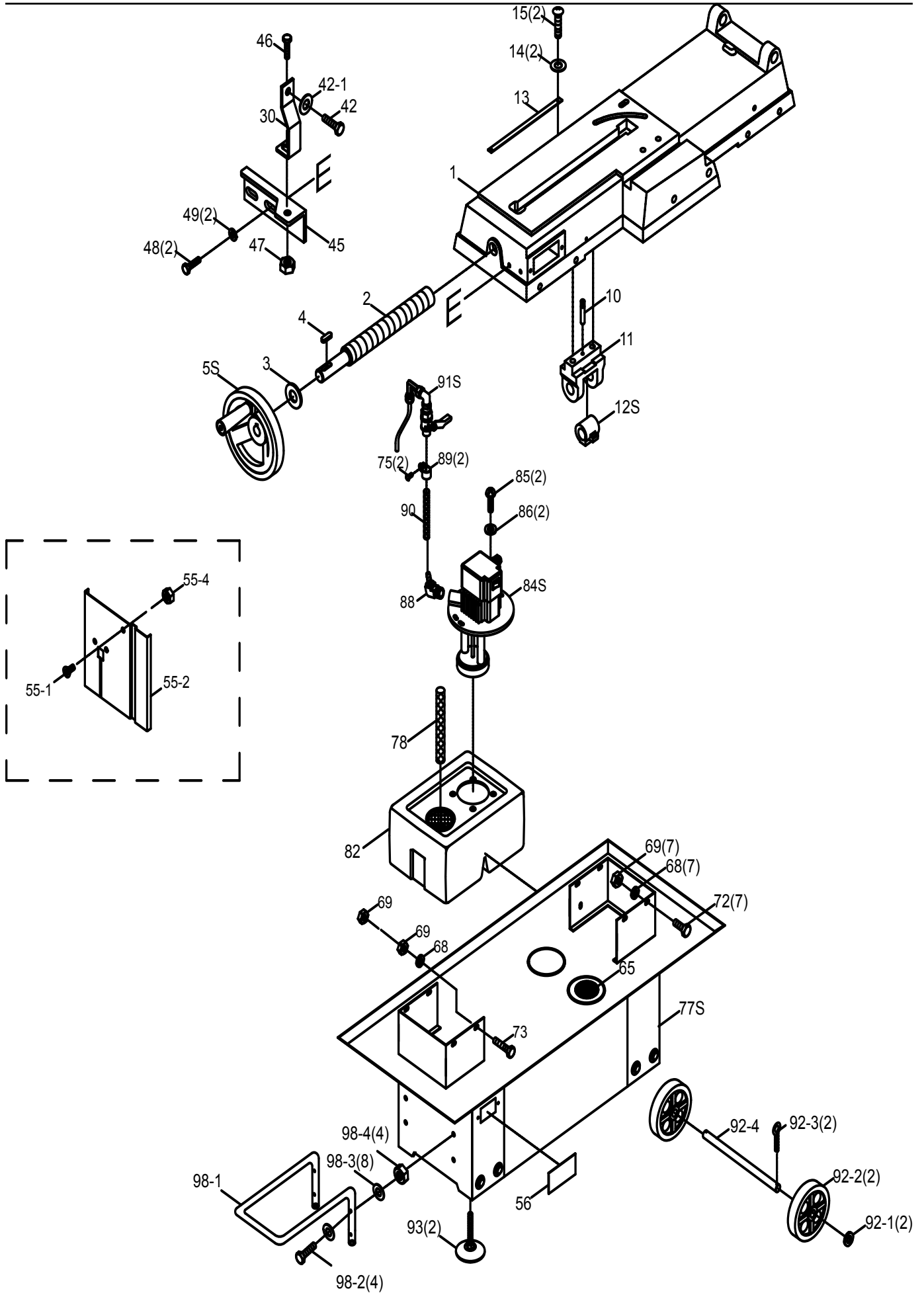

Assembly Diagrams - Continued

SAFETY

SETUP

OPERATION

MAINTENANCE

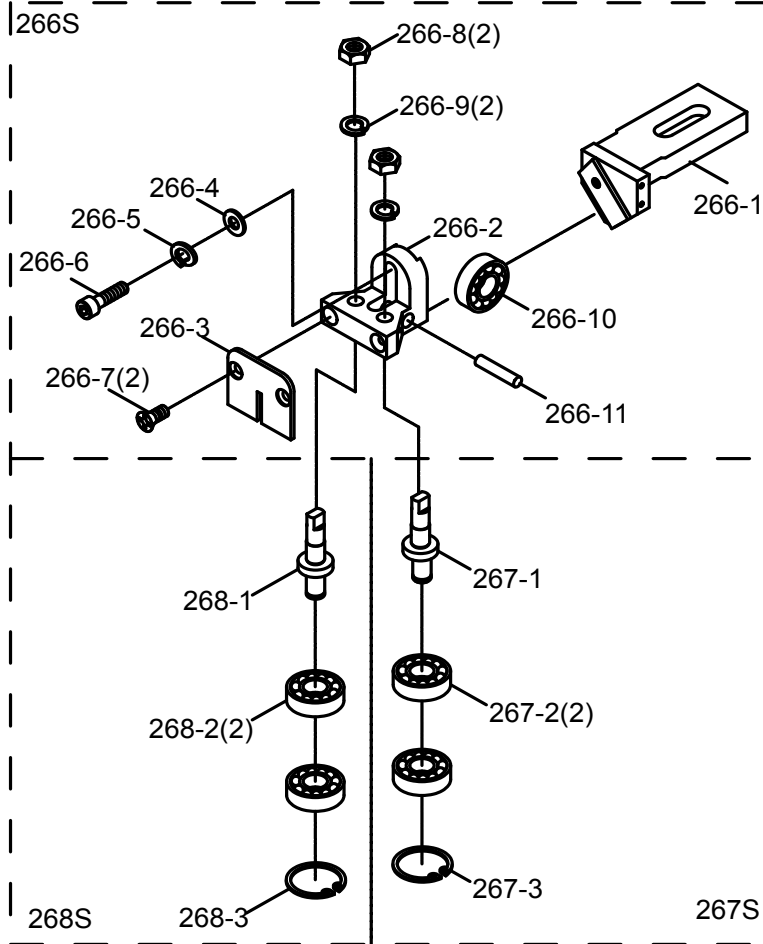
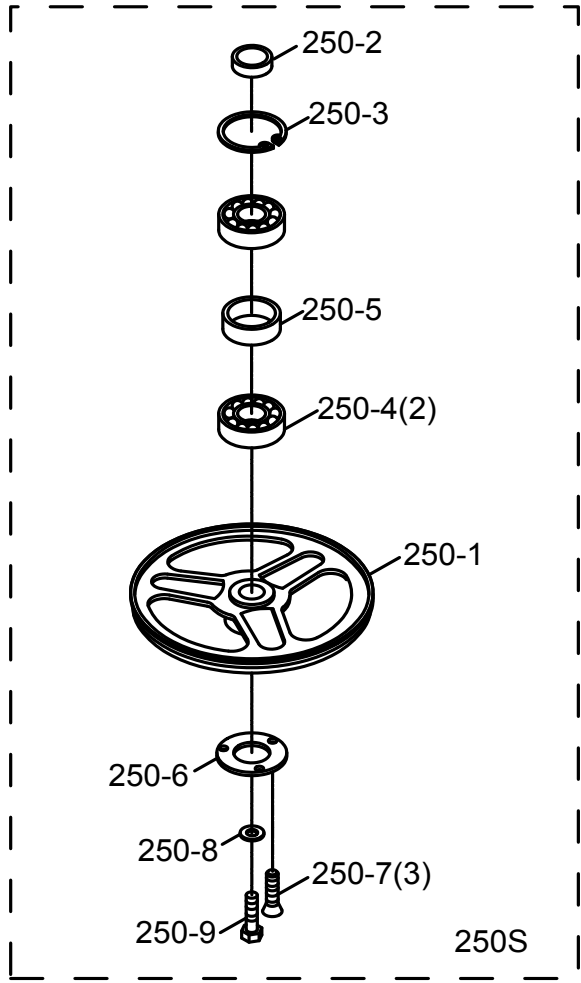
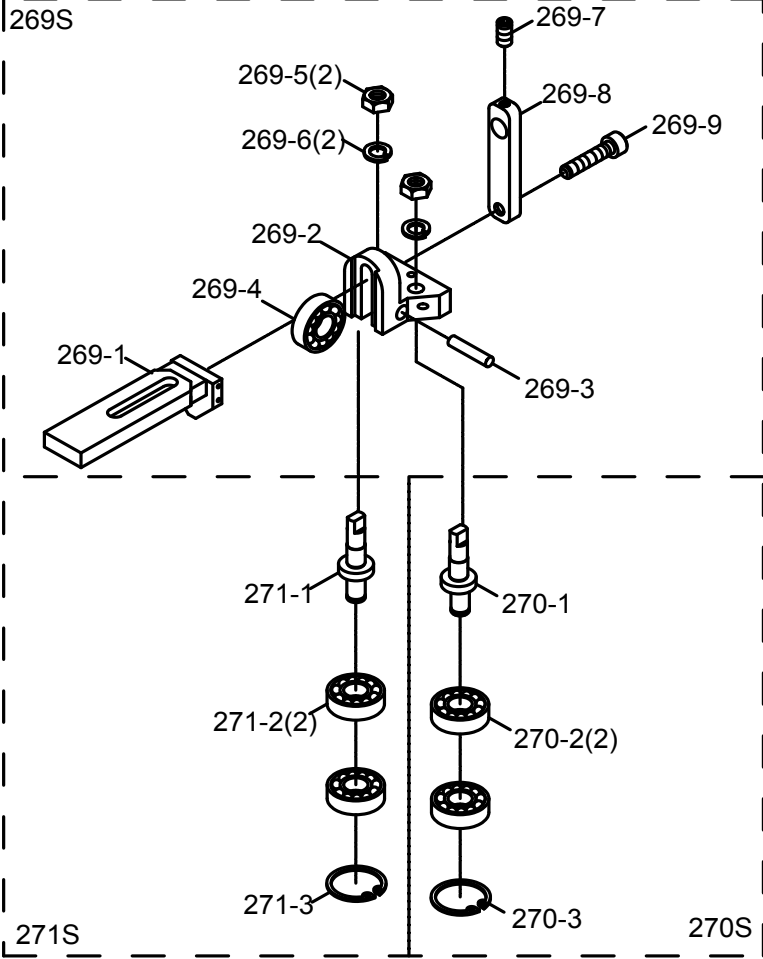

Assembly Diagrams - Continued

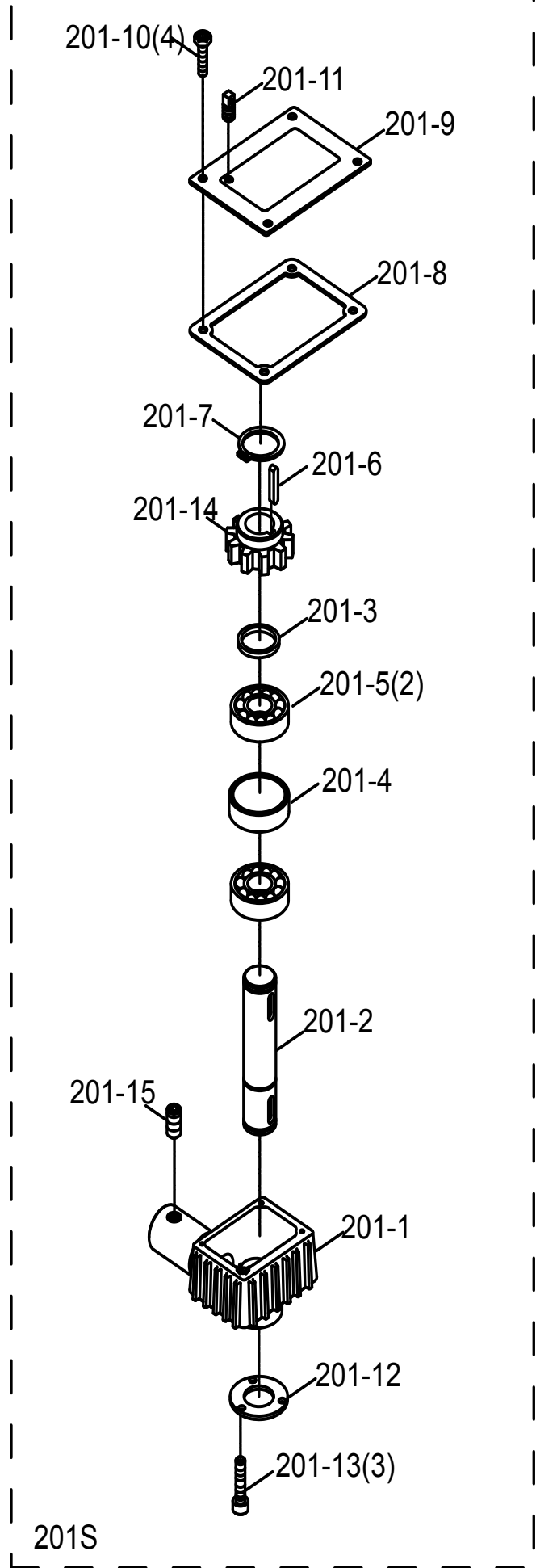
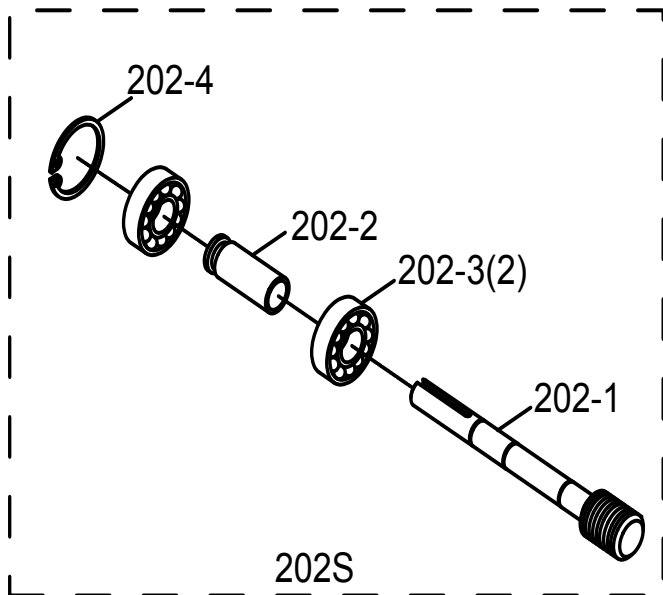

SAFETY

SETUP

OPERATION

MAINTENANCE

Assembly Diagrams - Continued

SAFETY

SETUP

OPERATION

MAINTENANCE

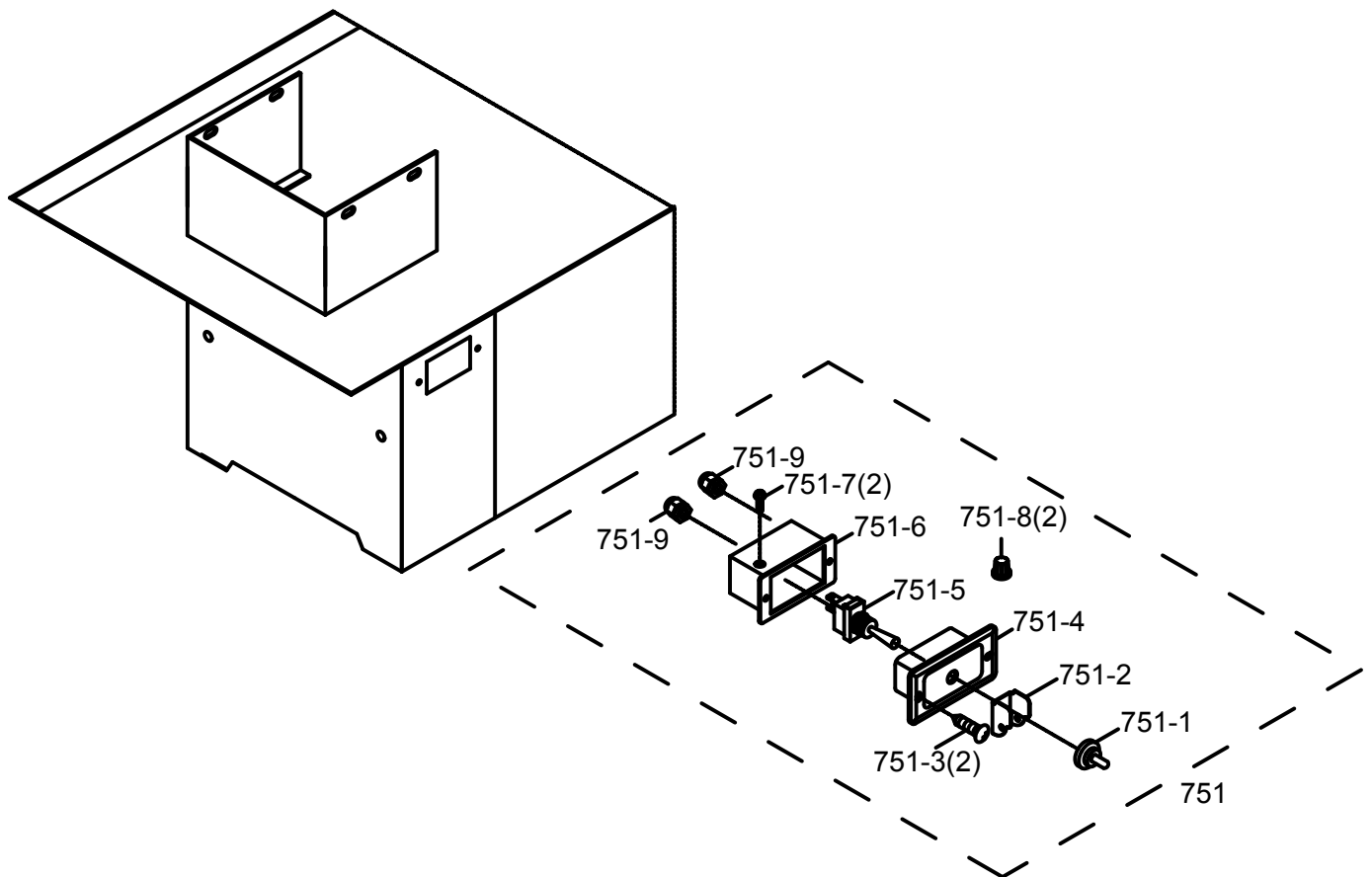
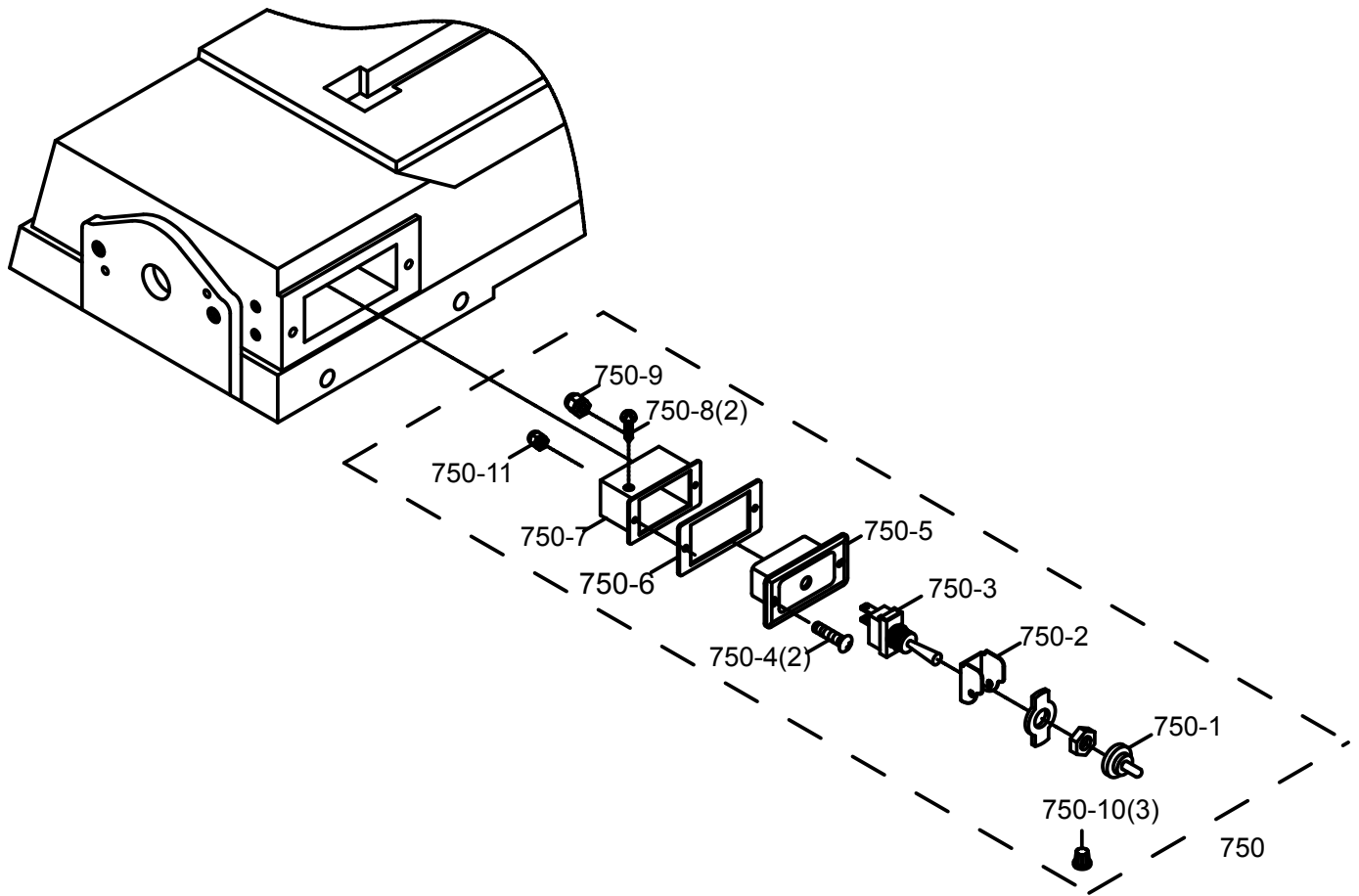

115VAC Electrical Schematic

230VAC Electrical Schematic

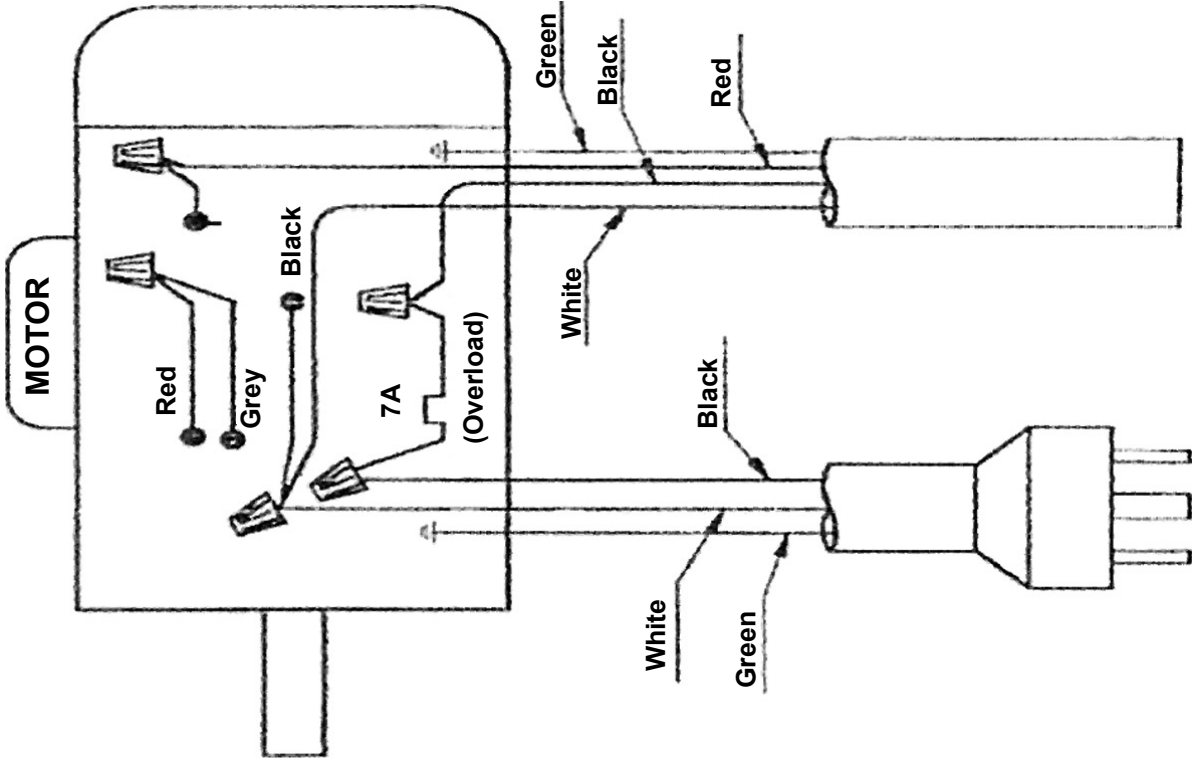
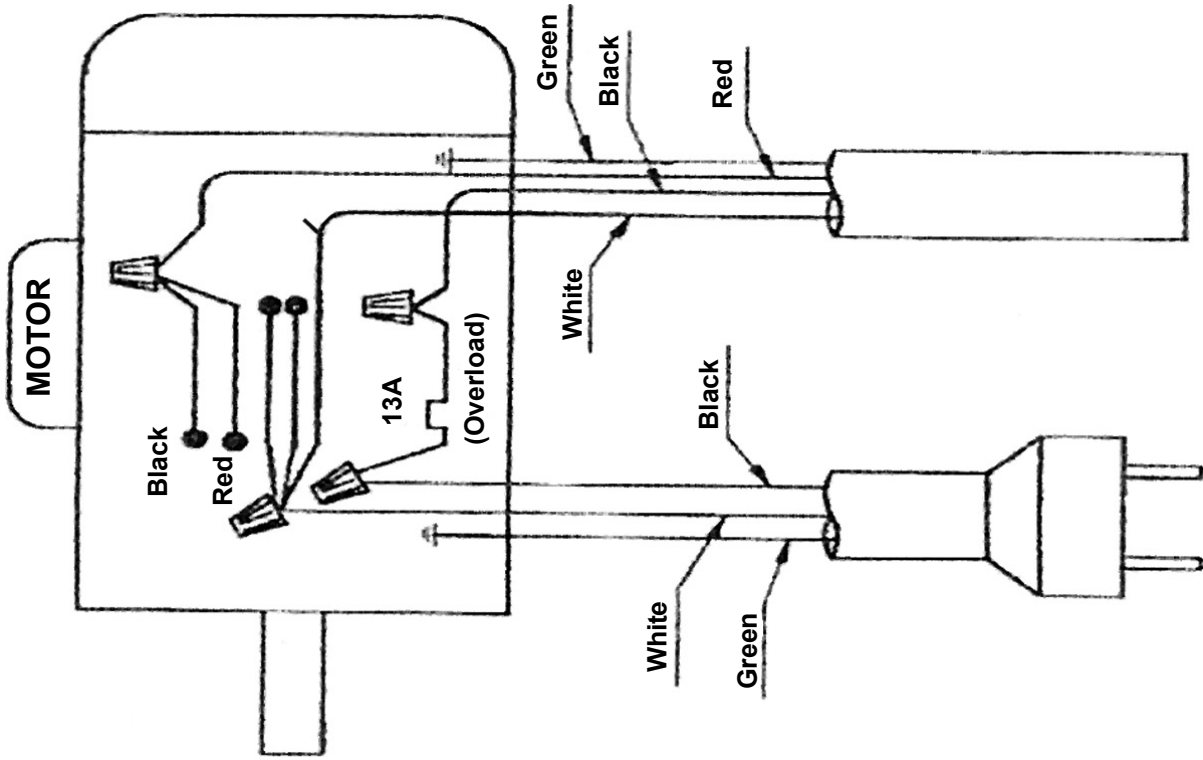

WARNING! To prevent serious injury and death from electrocution or fire, only a licensed electrician should attempt to rewire this machine.

Frequency Electrical Schematic

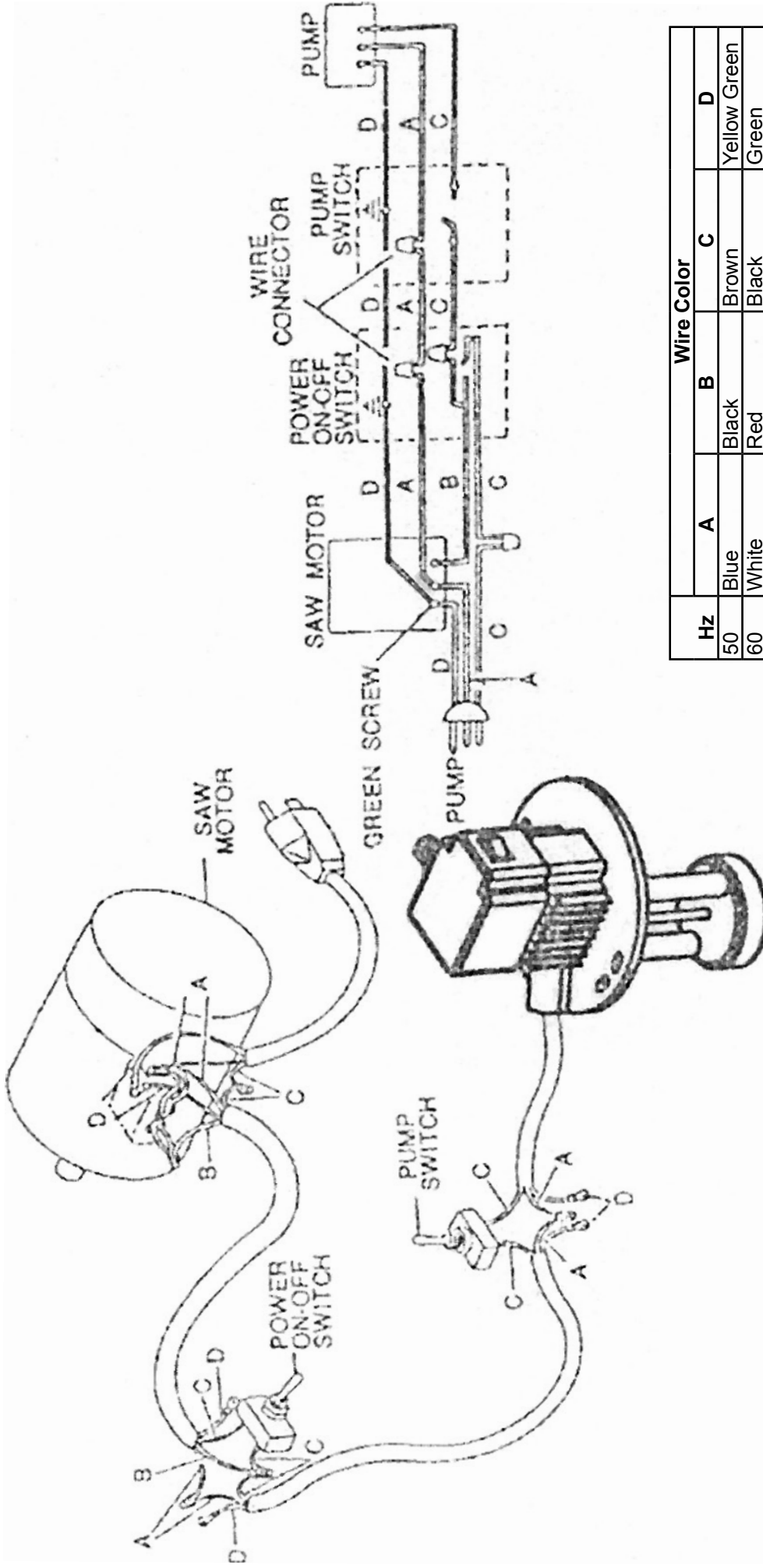

1 Phase Electrical Schematic

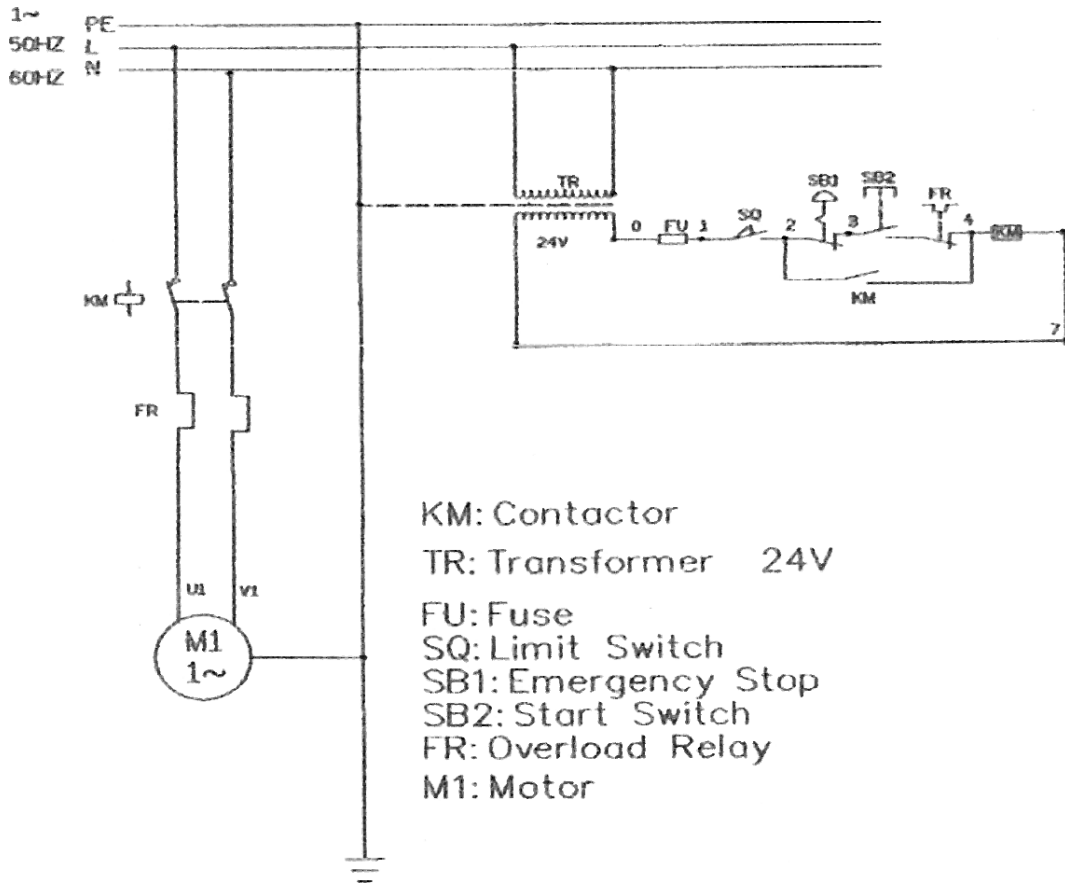

SAFETY

SETUP

3 Phase Electrical Schematic

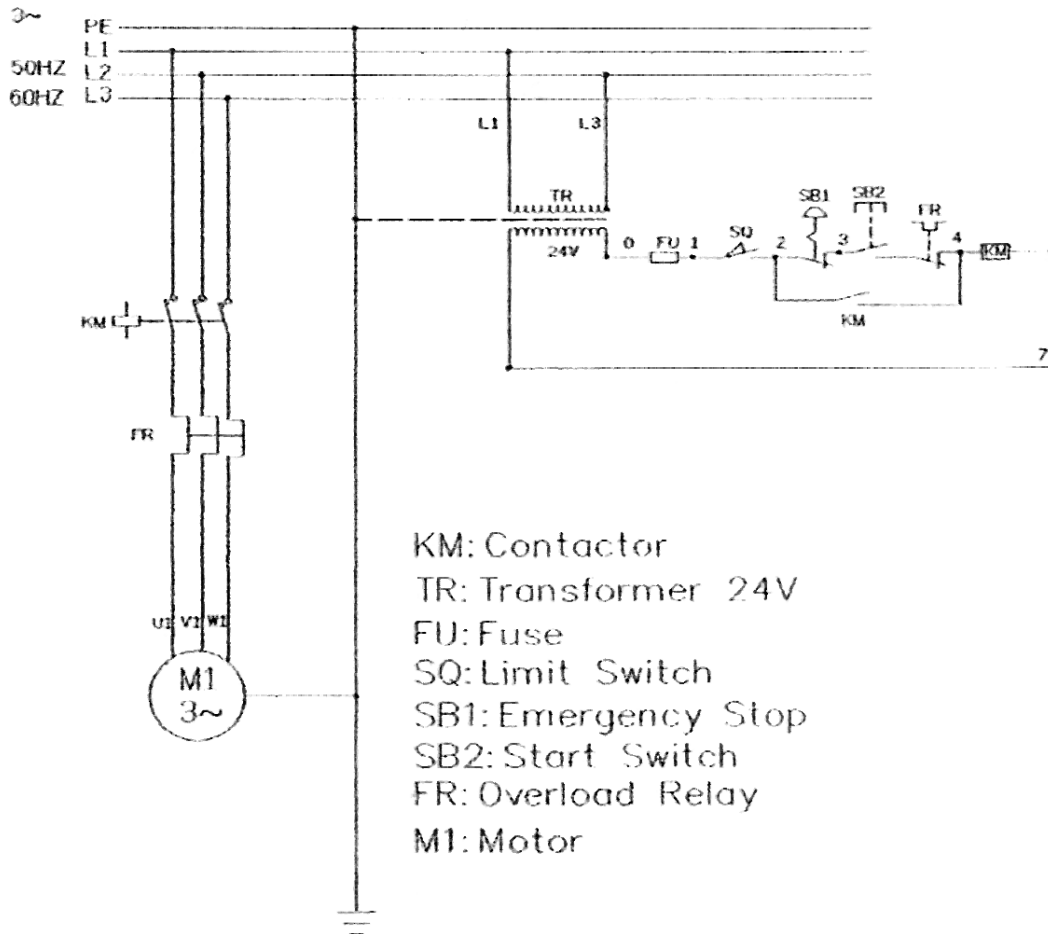

OPERATION

MAINTENANCE

Limited 90 Day Warranty

Harbor Freight Tools Co. makes every effort to assure that its products meet high quality and durability standards, and warrants to the original purchaser that this product is free from defects in materials and workmanship for the period of 90 days from the date of purchase. This warranty does not apply to damage due directly or indirectly, to misuse, abuse, negligence or accidents, repairs or alterations outside our facilities, criminal activity, improper installation, normal wear and tear, or to lack of maintenance. We shall in no event be liable for death, injuries to persons or property, or for incidental, contingent, special or consequential damages arising from the use of our product. Some states do not allow the exclusion or limitation of incidental or consequential damages, so the above limitation of exclusion may not apply to you. THIS WARRANTY IS EXPRESSLY IN LIEU OF ALL OTHER WARRANTIES, EXPRESS OR IMPLIED, INCLUDING THE WARRANTIES OF MERCHANTABILITY AND FITNESS.

To take advantage of this warranty, the product or part must be returned to us with transportation charges prepaid. Proof of purchase date and an explanation of the complaint must accompany the merchandise. If our inspection verifies the defect, we will either repair or replace the product at our election or we may elect to refund the purchase price if we cannot readily and quickly provide you with a replacement. We will return repaired products at our expense, but if we determine there is no defect, or that the defect resulted from causes not within the scope of our warranty, then you must bear the cost of returning the product.

This warranty gives you specific legal rights and you may also have other rights which vary from state to state.

CENTRAL
MACHINERY

26677 Agoura Road • Calabasas, CA 91302 • 1-800-444-3353