

Owner's Manual & Safety Instructions

Save This Manual Keep this manual for the safety warnings and precautions, assembly, operating, inspection, maintenance and cleaning procedures. Write the product's serial number in the back of the manual near the assembly diagram (or month and year of purchase if product has no number). Keep this manual and the receipt in a safe and dry place for future reference.

17g

63847

BATTERY OPERATED LIQUID TRANSFER PUMP



Visit our website at: <http://www.harborfreight.com>
Email our technical support at: productsupport@harborfreight.com

When unpacking, make sure that the product is intact and undamaged. If any parts are missing or broken, please call 1-888-866-5797 as soon as possible.





Copyright© 2017 by Harbor Freight Tools®. All rights reserved.

No portion of this manual or any artwork contained herein may be reproduced in any shape or form without the express written consent of Harbor Freight Tools. Diagrams within this manual may not be drawn proportionally. Due to continuing improvements, actual product may differ slightly from the product described herein. Tools required for assembly and service may not be included.

⚠WARNING

**Read this material before using this product.
Failure to do so can result in serious injury.
SAVE THIS MANUAL.**

WARNING SYMBOLS AND DEFINITIONS

	This is the safety alert symbol. It is used to alert you to potential personal injury hazards. Obey all safety messages that follow this symbol to avoid possible injury or death.
 DANGER	Indicates a hazardous situation which, if not avoided, will result in death or serious injury.
 WARNING	Indicates a hazardous situation which, if not avoided, could result in death or serious injury.
 CAUTION	Indicates a hazardous situation which, if not avoided, could result in minor or moderate injury.
NOTICE CAUTION	Addresses practices not related to personal injury.

Specifications

Battery Requirement	Two D-Cell (not included)
Delivery Hose Length	24"
Suction Hose	13" L x 1" Diameter
Flow Rate	Approximately 6 Quarts/Min
Compatible Fluids	Gasoline, Water, Oil, other Non-Corrosive Liquids

IMPORTANT SAFETY INFORMATION



WARNING Read all safety warnings and instructions.

Failure to follow the warnings and instructions may result in serious injury.

Save all warnings and instructions for future reference.

1. Do not use with corrosive liquids. Not for use with drinking water.
2. When pumping gasoline and flammable liquids, be alert to possible explosion hazard. Flammable fluid fumes and gasoline vapors can be an explosive hazard. Avoid sparks and use only with adequate ventilation.
3. Wear ANSI-approved safety goggles and heavy-duty, chemical resistant work gloves during use.
4. This product is not a toy. Do not allow children to play with or near this item.
5. Use as intended only. Only use pump for transferring gasoline, water, oil, and other non-corrosive liquids.
6. Do not use if Pump is hot.
7. Verify that all connections are tight before use to eliminate leaking.
8. Do not pump used, dirty oil.
9. Do not use near open flame or heat sources.
10. Do not turn Pump upside down after use.
11. Remove batteries when not in use.
12. Know and obey city and state laws for proper disposal of oil and gasoline. Dispose of properly in accordance with all local laws and regulations.
13. Follow all guidelines regarding materials being pumped, including SDS instructions and EPA regulations.
14. Do not mix old and new batteries. Do not mix alkaline, standard (carbon-zinc), or rechargeable (nickel-cadmium) batteries. Position batteries in proper polarity. Do not use swollen or leaking batteries.
15. Do not operate when tired or when under the influence of drugs or medication.
16. Inspect before every use; do not use if parts are loose or damaged.
17. Maintain product labels and nameplates. These carry important safety information. If unreadable or missing, contact Harbor Freight Tools for a replacement.



SAVE THESE INSTRUCTIONS.

Operating Instructions



Read the **ENTIRE WARNING** section at the beginning of this manual including all text under subheadings therein before set up or use of this product.

Note: For additional information regarding the parts listed in the following pages, refer to the *Parts List and Diagram* on page 4.

Battery Installation

1. Unscrew Battery Cap counterclockwise and remove.
2. Insert two D-Cell batteries (not included) into the Battery Housing. Be sure to install batteries in proper polarity. Do not install batteries of different types, charge levels, or capacities together.
3. Replace the Battery Cap and tighten securely.

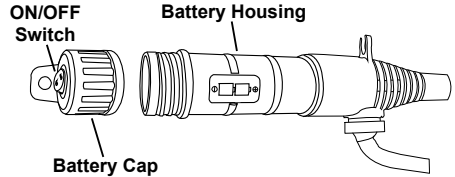

Figure A

Operation

1. Insert the Suction Tube as far as possible into the liquid to be transferred.
2. Place the Delivery Hose into a container (not included) in which to pump the liquid. Do not place receiving container higher than the Battery Housing.
3. Turn the ON/OFF Switch to ON. Make sure the battery compartment remains sealed during operation.
4. When the transfer is complete, turn the Switch OFF. After use, do not turn Pump upside down.
5. Rinse unit with water and wipe dry. Remove batteries and store in a clean, dry location out of reach of children.

NOTICE: Do not run unit dry. Make sure Suction Tube is fully submerged in liquid before turning on.

Maintenance



Procedures not specifically explained in this manual must be performed only by a qualified technician.

WARNING

TO PREVENT SERIOUS INJURY FROM TOOL FAILURE: Do not use damaged equipment. If abnormal noise or vibration occurs, have the problem corrected before further use.

1. **BEFORE EACH USE**, inspect the general condition of the Liquid Transfer Pump. Check for:
 - loose hardware
 - misalignment or binding of moving parts
 - cracked or broken parts
 - any other condition that may affect its safe operation.
2. **AFTER USE**, rinse Pump with water. Wipe unit dry after cleaning.
3. Remove batteries. Store the Liquid Transfer Pump in a clean, dry location out of reach of children.

PLEASE READ THE FOLLOWING CAREFULLY

THE MANUFACTURER AND/OR DISTRIBUTOR HAS PROVIDED THE PARTS LIST AND ASSEMBLY DIAGRAM IN THIS MANUAL AS A REFERENCE TOOL ONLY. NEITHER THE MANUFACTURER OR DISTRIBUTOR MAKES ANY REPRESENTATION OR WARRANTY OF ANY KIND TO THE BUYER THAT HE OR SHE IS QUALIFIED TO MAKE ANY REPAIRS TO THE PRODUCT, OR THAT HE OR SHE IS QUALIFIED TO REPLACE ANY PARTS OF THE PRODUCT. IN FACT, THE MANUFACTURER AND/OR DISTRIBUTOR EXPRESSLY STATES THAT ALL REPAIRS AND PARTS REPLACEMENTS SHOULD BE UNDERTAKEN BY CERTIFIED AND LICENSED TECHNICIANS, AND NOT BY THE BUYER. THE BUYER ASSUMES ALL RISK AND LIABILITY ARISING OUT OF HIS OR HER REPAIRS TO THE ORIGINAL PRODUCT OR REPLACEMENT PARTS THERETO, OR ARISING OUT OF HIS OR HER INSTALLATION OF REPLACEMENT PARTS THERETO.

Parts List & Diagram

Part	Description	Qty
1	Battery Cover / ON/OFF Switch	1
2	Neck Ring	1
3	Battery Housing	1
4	Circuit Board	1
5	Pump Housing	1
6	Suction Tube	1
7	Seal	1
8	Motor Housing	1
9	Motor	1
10	Seal	1
11	Washer	1
12	Impeller	1
13	End Cap	1
14	Delivery Hose Ring	1
15	Delivery Hose	1

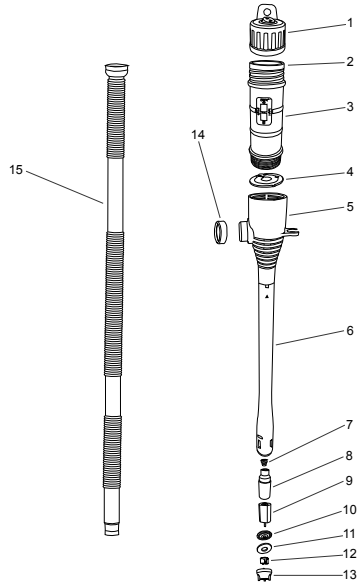

Record Serial Number Here: _____

Note: If product has no serial number, record month and year of purchase instead.

Note: Some parts are listed and shown for illustration purposes only, and are not available individually as replacement parts.

Limited 90 Day Warranty

Harbor Freight Tools Co. makes every effort to assure that its products meet high quality and durability standards, and warrants to the original purchaser that this product is free from defects in materials and workmanship for the period of 90 days from the date of purchase. This warranty does not apply to damage due directly or indirectly, to misuse, abuse, negligence or accidents, repairs or alterations outside our facilities, criminal activity, improper installation, normal wear and tear, or to lack of maintenance. We shall in no event be liable for death, injuries to persons or property, or for incidental, contingent, special or consequential damages arising from the use of our product. Some states do not allow the exclusion or limitation of incidental or consequential damages, so the above limitation of exclusion may not apply to you. THIS WARRANTY IS EXPRESSLY IN LIEU OF ALL OTHER WARRANTIES, EXPRESS OR IMPLIED, INCLUDING THE WARRANTIES OF MERCHANTABILITY AND FITNESS.

To take advantage of this warranty, the product or part must be returned to us with transportation charges prepaid. Proof of purchase date and an explanation of the complaint must accompany the merchandise. If our inspection verifies the defect, we will either repair or replace the product at our election or we may elect to refund the purchase price if we cannot readily and quickly provide you with a replacement. We will return repaired products at our expense, but if we determine there is no defect, or that the defect resulted from causes not within the scope of our warranty, then you must bear the cost of returning the product.

This warranty gives you specific legal rights and you may also have other rights which vary from state to state.

3491 Mission Oaks Blvd. • P. O. Box 6009 • Camarillo, CA 93011 • 1-888-866-5797