

# Owner's Manual & Safety Instructions

**Save This Manual** Keep this manual for the safety warnings and precautions, assembly, operating, inspection, maintenance and cleaning procedures. Write the product's serial number in the back of the manual near the assembly diagram (or month and year of purchase if product has no number). Keep this manual and the receipt in a safe and dry place for future reference.

18f

**PITTSBURGH<sup>®</sup> AUTOMOTIVE**

**63902**

## ***Suction Gun***



Visit our website at: <http://www.harborfreight.com>  
Email our technical support at: [productsupport@harborfreight.com](mailto:productsupport@harborfreight.com)

When unpacking, make sure that the product is intact and undamaged. If any parts are missing or broken, please call 1-888-866-5797 as soon as possible.





Copyright© 2017 by Harbor Freight Tools®. All rights reserved.

No portion of this manual or any artwork contained herein may be reproduced in any shape or form without the express written consent of Harbor Freight Tools. Diagrams within this manual may not be drawn proportionally. Due to continuing improvements, actual product may differ slightly from the product described herein. Tools required for assembly and service may not be included.

### **⚠ WARNING**

Read this material before using this product. Failure to do so can result in serious injury. **SAVE THIS MANUAL.**

## WARNING SYMBOLS AND DEFINITIONS

	This is the safety alert symbol. It is used to alert you to potential personal injury hazards. Obey all safety messages that follow this symbol to avoid possible injury or death.
 <b>DANGER</b>	Indicates a hazardous situation which, if not avoided, will result in death or serious injury.
 <b>WARNING</b>	Indicates a hazardous situation which, if not avoided, could result in death or serious injury.
 <b>CAUTION</b>	Indicates a hazardous situation which, if not avoided, could result in minor or moderate injury.
<b>NOTICE</b> <b>CAUTION</b>	Addresses practices not related to personal injury.

## Specifications

Capacity	16.9 oz.
Hose Dimensions	12" L x 1/2" O.D.
Compatible Fluids	Any type of fluid lubricant

## IMPORTANT SAFETY INFORMATION



### **WARNING** Read all safety warnings and instructions.

*Failure to follow the warnings and instructions may result in serious injury.*

**Save all warnings and instructions for future reference.**

1. Wear ANSI-approved safety goggles and heavy-duty, chemical resistant work gloves during use.
2. Keep work area clean and well lit.
3. Keep bystanders out of the work area.
4. Do not operate when tired or when under the influence of drugs or medication.
5. This product is not a toy. Do not allow children to play with or near this item.
6. Use as intended only. Only use pump with non-corrosive lubricants. Do not use with gasoline.
7. Inspect before every use; do not use if parts are loose or damaged.
8. Know and obey city and state laws for proper disposal of oil. Recycle or dispose of oil properly in accordance with all local laws and regulations.
9. Do not use near open flame or other ignition sources.
10. When transferring oil, make certain that fluid is sufficiently cool prior to transfer. If transferring from a vehicle, make sure vehicle's engine is off, and oil and engine components are cool.
11. Follow all guidelines regarding materials being transferred, including SDS instructions and EPA regulations.
12. Maintain product labels and nameplates. These carry important safety information. If unreadable or missing, contact Harbor Freight Tools for a replacement.



## **SAVE THESE INSTRUCTIONS.**

## Operating Instructions



Read the **ENTIRE WARNING** section at the beginning of this manual including all text under subheadings therein before set up or use of this product.

**Note:** For additional information regarding the parts listed in the following pages, refer to the *Parts List and Diagram* on page 4.

## Draining Fluid

1. Submerge the Hose as far as possible into the lubricant to be transferred.
2. Hold onto the Tube with one hand and grasp the Handle with the other hand.
3. Pull up on the Handle to create suction and fill up the Tube. Use a rag on the hose end to prevent dripping.
4. Place the Suction Gun over a collection receptacle (not included) that can be closed and covered for transfer. Push down on the Handle or unscrew the Front Cover and pour lubricant out from the Tube into the collection receptacle.

## To Fill With Fluid

1. Fill the Tube using the above steps.
2. Push down on the Handle to inject lubricant through the Hose into the transmission, clutch or differential.

## Maintenance



Procedures not specifically explained in this manual must be performed only by a qualified technician.

### **!WARNING**

**TO PREVENT SERIOUS INJURY FROM TOOL FAILURE: Do not use damaged equipment. If abnormal noise or vibration occurs, have the problem corrected before further use.**

1. **BEFORE EACH USE**, inspect the general condition of the Suction Gun. Check for:
  - loose hardware
  - misalignment or binding of moving parts
  - cracked or broken parts
  - any other condition that may affect its safe operation.
2. **AFTER USE**, wipe unit off using a clean, dry cloth.
3. Store the Suction Gun in a clean, dry location out of reach of children.

## PLEASE READ THE FOLLOWING CAREFULLY

THE MANUFACTURER AND/OR DISTRIBUTOR HAS PROVIDED THE PARTS LIST AND ASSEMBLY DIAGRAM IN THIS MANUAL AS A REFERENCE TOOL ONLY. NEITHER THE MANUFACTURER OR DISTRIBUTOR MAKES ANY REPRESENTATION OR WARRANTY OF ANY KIND TO THE BUYER THAT HE OR SHE IS QUALIFIED TO MAKE ANY REPAIRS TO THE PRODUCT, OR THAT HE OR SHE IS QUALIFIED TO REPLACE ANY PARTS OF THE PRODUCT. IN FACT, THE MANUFACTURER AND/OR DISTRIBUTOR EXPRESSLY STATES THAT ALL REPAIRS AND PARTS REPLACEMENTS SHOULD BE UNDERTAKEN BY CERTIFIED AND LICENSED TECHNICIANS, AND NOT BY THE BUYER. THE BUYER ASSUMES ALL RISK AND LIABILITY ARISING OUT OF HIS OR HER REPAIRS TO THE ORIGINAL PRODUCT OR REPLACEMENT PARTS THERETO, OR ARISING OUT OF HIS OR HER INSTALLATION OF REPLACEMENT PARTS THERETO.

## Parts List & Diagram

Part	Description	Qty
1	Handle	1
2	Rear Cover	1
3	Rubber Gasket	1
4	Tube	1
5	Front Cover	1
6	Nozzle	1

Part	Description	Qty
7	Hose	1
8	Spring	1
9	Follower Rod	1
10	Spacer	2
11	Plunger	1
12	Hex Nut	1

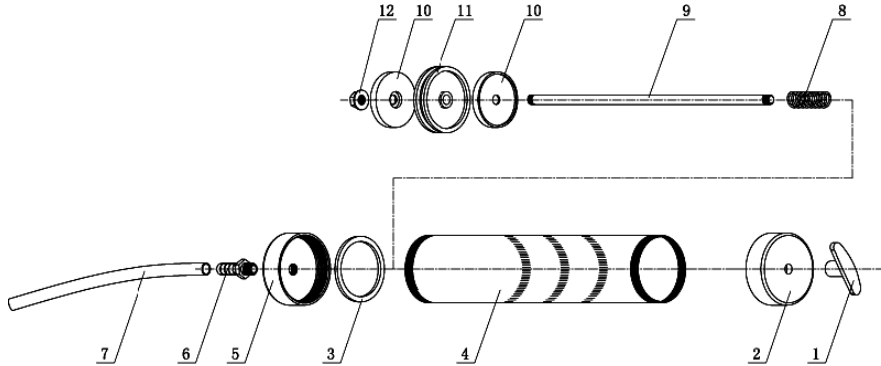

**Record Serial Number Here:** \_\_\_\_\_

**Note:** If product has no serial number, record month and year of purchase instead.

**Note:** Some parts are listed and shown for illustration purposes only, and are not available individually as replacement parts.

## Limited 90 Day Warranty

Harbor Freight Tools Co. makes every effort to assure that its products meet high quality and durability standards, and warrants to the original purchaser that this product is free from defects in materials and workmanship for the period of 90 days from the date of purchase. This warranty does not apply to damage due directly or indirectly, to misuse, abuse, negligence or accidents, repairs or alterations outside our facilities, criminal activity, improper installation, normal wear and tear, or to lack of maintenance. We shall in no event be liable for death, injuries to persons or property, or for incidental, contingent, special or consequential damages arising from the use of our product. Some states do not allow the exclusion or limitation of incidental or consequential damages, so the above limitation of exclusion may not apply to you. THIS WARRANTY IS EXPRESSLY IN LIEU OF ALL OTHER WARRANTIES, EXPRESS OR IMPLIED, INCLUDING THE WARRANTIES OF MERCHANTABILITY AND FITNESS.

To take advantage of this warranty, the product or part must be returned to us with transportation charges prepaid. Proof of purchase date and an explanation of the complaint must accompany the merchandise. If our inspection verifies the defect, we will either repair or replace the product at our election or we may elect to refund the purchase price if we cannot readily and quickly provide you with a replacement. We will return repaired products at our expense, but if we determine there is no defect, or that the defect resulted from causes not within the scope of our warranty, then you must bear the cost of returning the product.

This warranty gives you specific legal rights and you may also have other rights which vary from state to state.

# PITTSBURGH<sup>®</sup> AUTOMOTIVE

3491 Mission Oaks Blvd. • P. O. Box 6009 • Camarillo, CA 93011 • 1-888-866-5797